



## Pixel Ribbon Go Flat Mounting Guide

### Safety Information

- When handling the products, wear anti-static wristbands with earthing terminals or anti-static gloves.
- The LED strip itself and all its components may not be mechanically stressed.
- Care should be taken to avoid damage to the conducting paths on the circuit board of the LED strip during assembly, mounting and connection.
- Do not connect or disconnect the LED strip when the circuit is powered.
- Do not connect the LED strip to the power supply while it is in the packing or rolled on the reel.
- Interconnection shall be made only by the use of the supplied connectors. For flat version, any open ends must be sealed-off before use.
- Please read the mounting guide carefully for detailed installation planning.

### Dimensions

Model	Max. Ribbon length with single power feed (L1)	Actual product length with end cap at 2-ends (L2)
RGBW (14.4W/m) & RGB (11W/m)	CE: 8000mm [315"] ETL: 6000mm [236.22"]	8028mm [316.06"] ± 10mm [0.39"] ETL: 6028mm [237.32"] ± 10mm [0.39"]
DW & W (9.6W/m)	CE: 10000mm [393.7"] ETL: 6000mm [236.22"]	10028mm [394.8"] ± 10mm [0.39"] ETL: 6028mm [237.32"] ± 10mm [0.39"]

Remark: For other customize lengths (in multiply of 100mm / 4"), the actual product length would be customize length ± 10mm [0.39"].

### Clear

Unit: mm [inch]

#### White

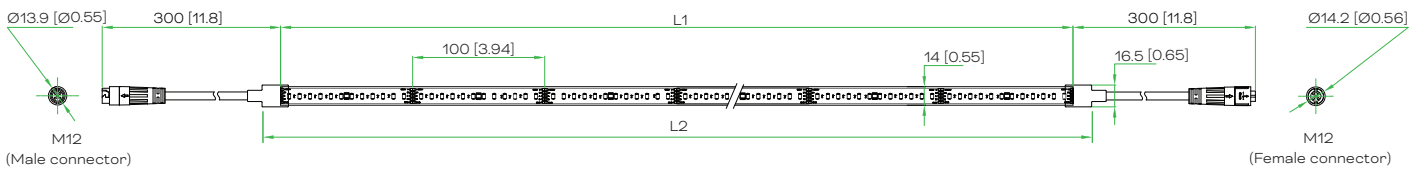

#### DW

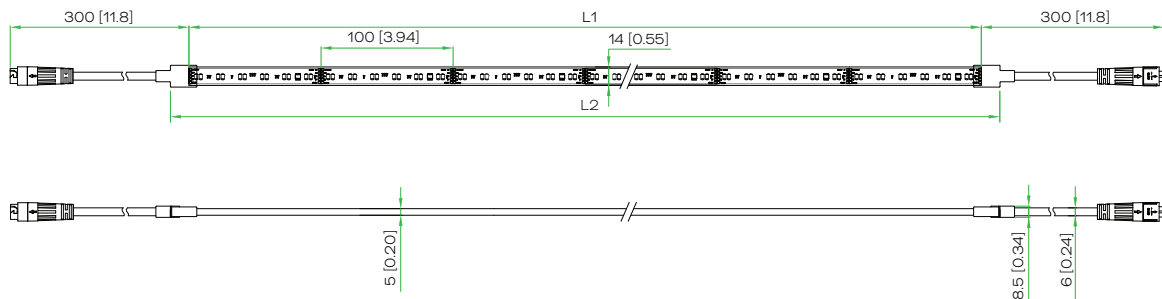

#### RGB&RGBW

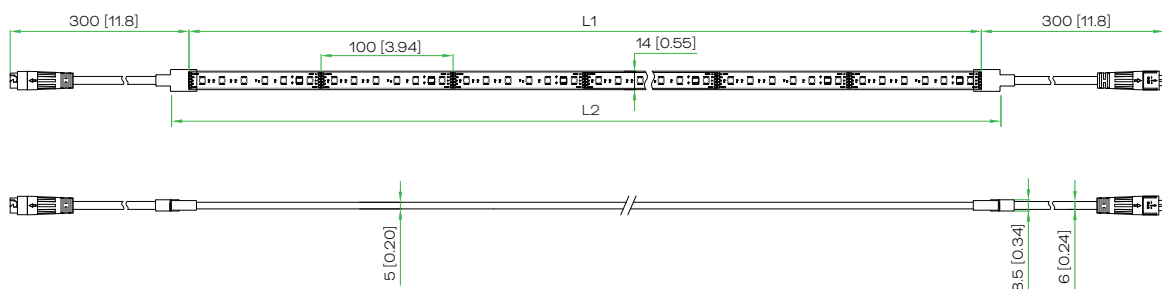



## Diffused

Unit: mm [inch]

White&DW&RGB&RGBW

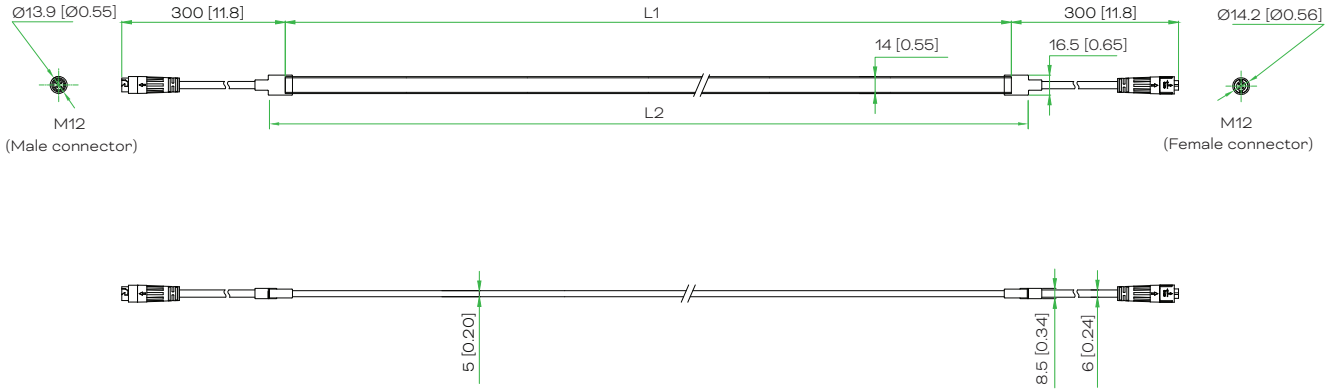

## Do's and Don'ts



**Min. Bending Radius for Ribbon body:** 1.97"/50 mm  
**Min. Bending Radius for cable:** 0.79"/20mm

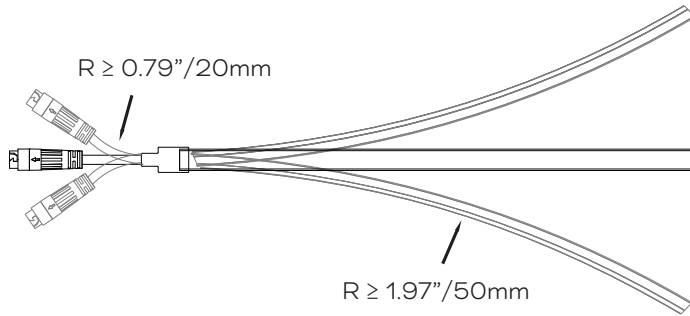

**DO NOT** twist Pixel Ribbon Go.  
 Damage will be caused to the internal circuitry.

Non-Bendable Length of 0.79"/20 mm near the connector end or near the ribbon cable entry **MUST** be adhered to.

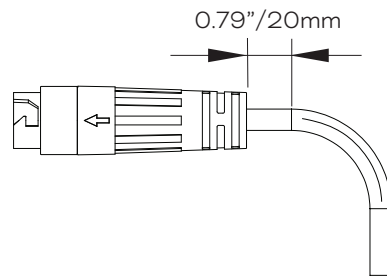



## Mounting with Silicone Mounting Clip

Unit: mm [inch]

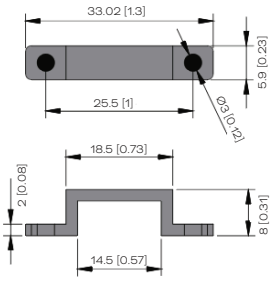

Description

Item Code

MOUNTING CLIP FLAT RB 20PC

AM412900055

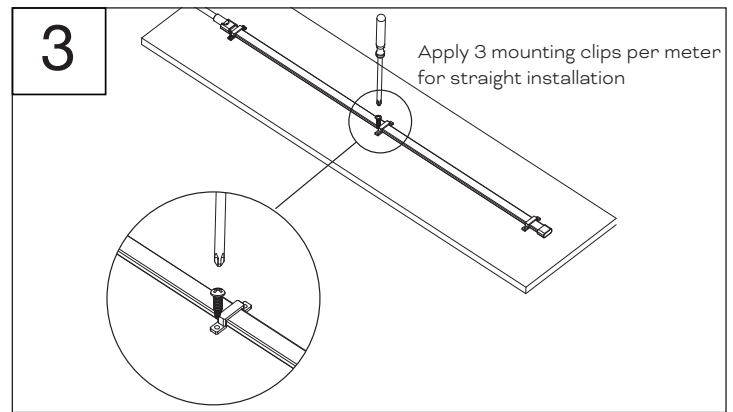
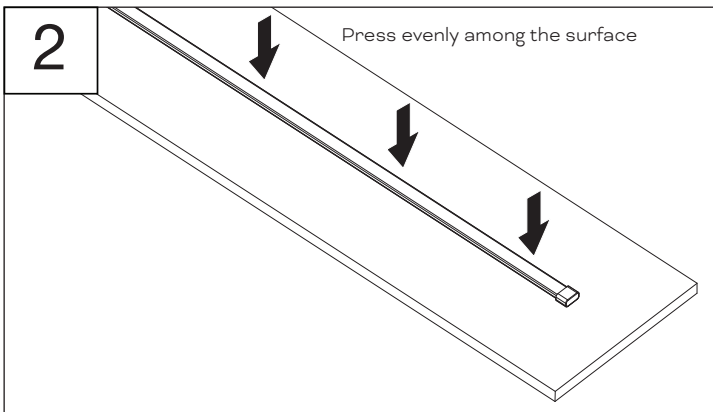
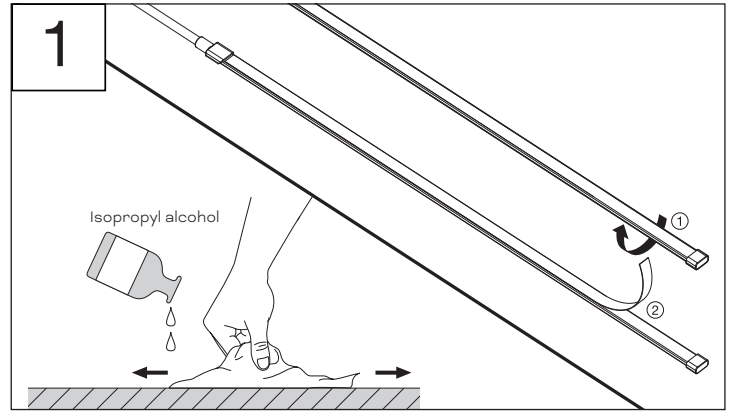

## Mounting on U-Channel

Unit: mm [inch]

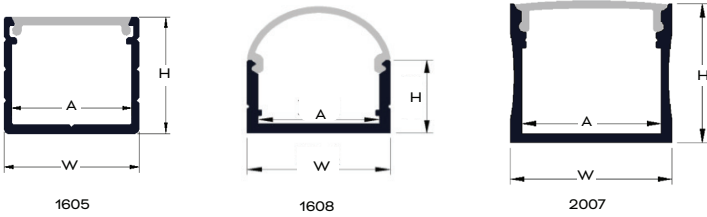

	1605	1608	2007
Item Code	AM412910055	AM412920055	AM412930055
W	18 [0.71]	19.4 [0.76]	23.5 [0.93]
A	16 [0.63]	16.4 [0.65]	20.2 [0.8]
H	13 [0.51]	11.6 [0.46]	20.5 [0.81]
Length	950 [37.4]	950 [37.4]	1000 [39.37]

NOTE: Pixel Ribbon Go Flat is mounted to the channel by 3M tape.

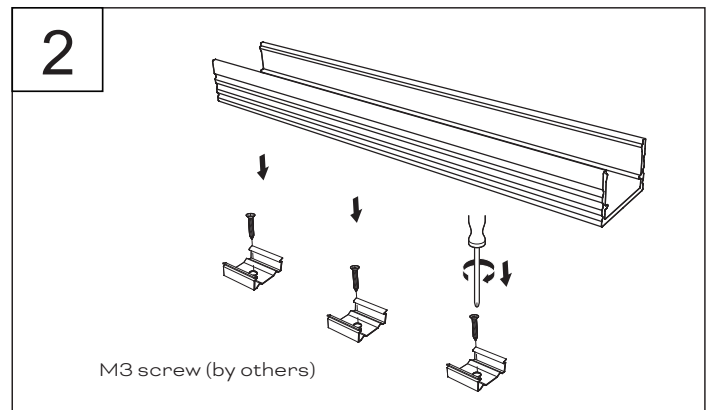
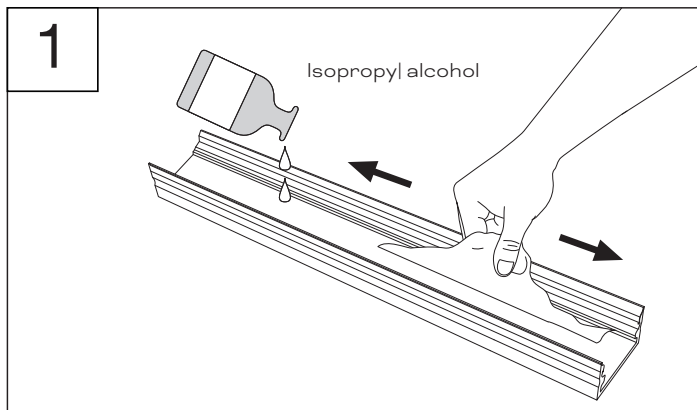



## Mounting on U-Channel

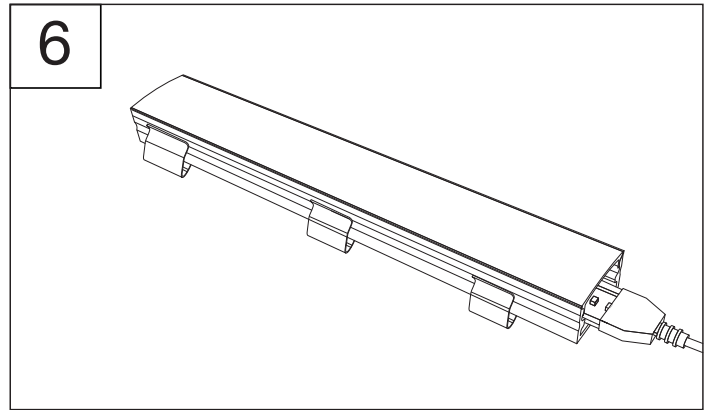
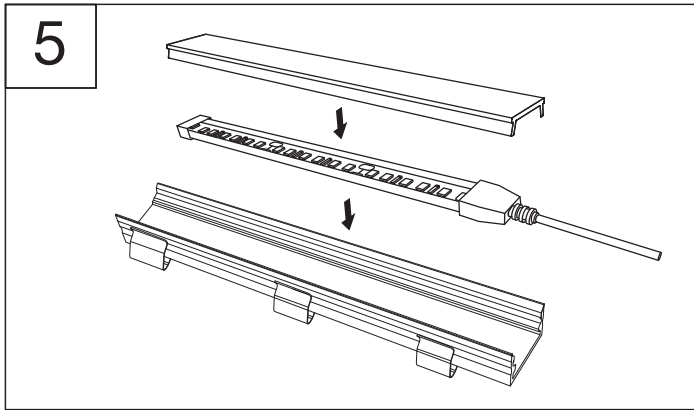
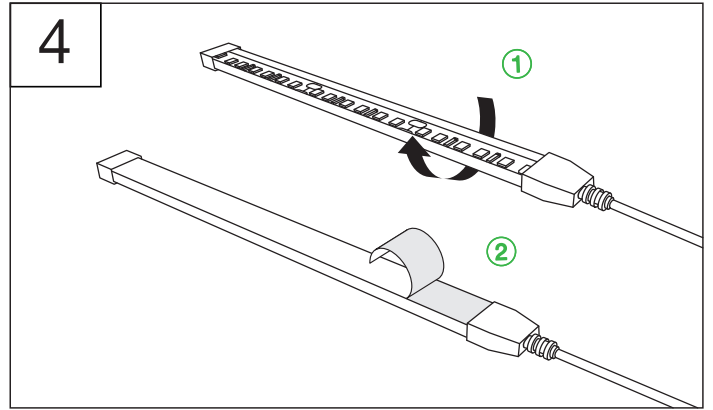
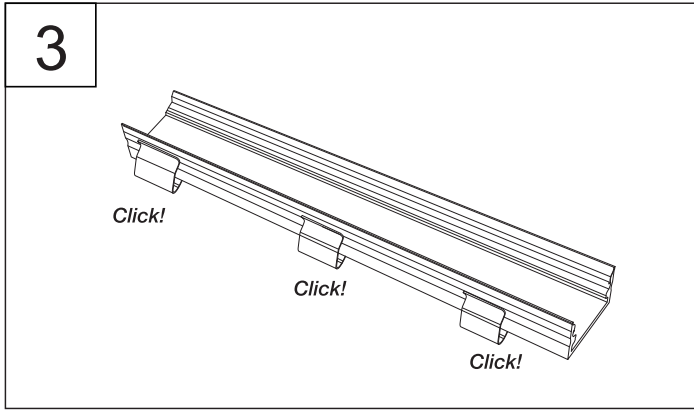

## Mounting on V-Channel

Unit: mm [inch]

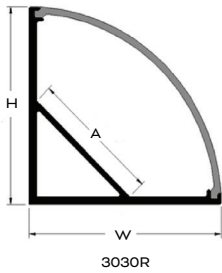

3030R	
Item Code	AM412940055
W	30 [1.18]
A	20.6 [0.81]
H	30 [1.18]
Length	1000 [39.37]

NOTE: Pixel Ribbon Go Flat is mounted to the channel by 3M tape.

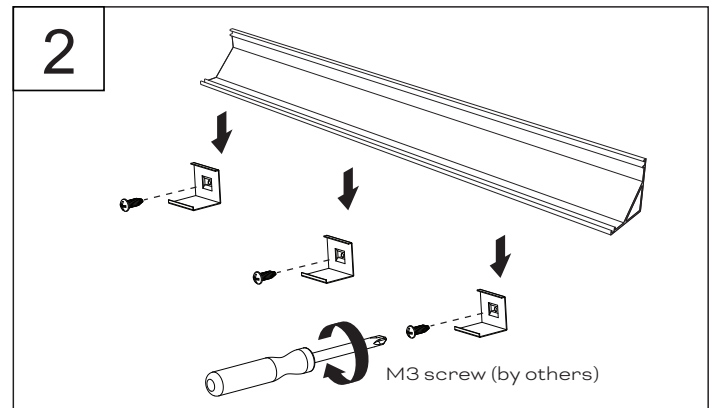
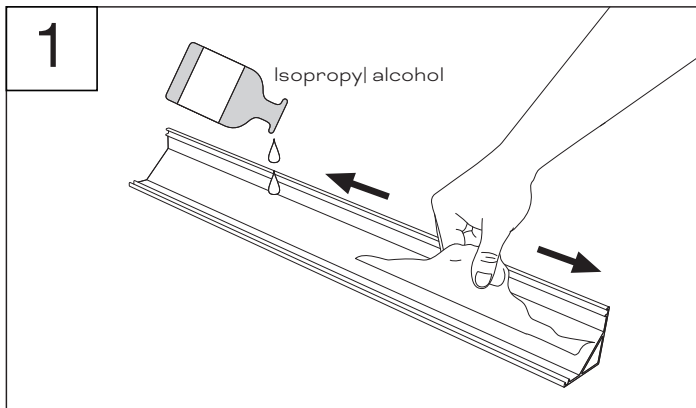

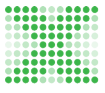

## Mounting on V-Channel

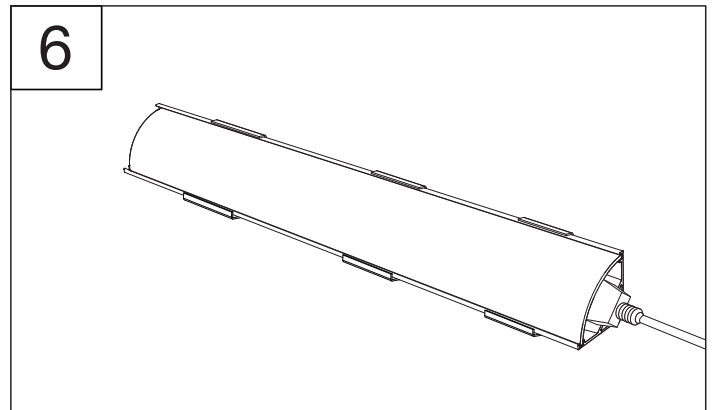
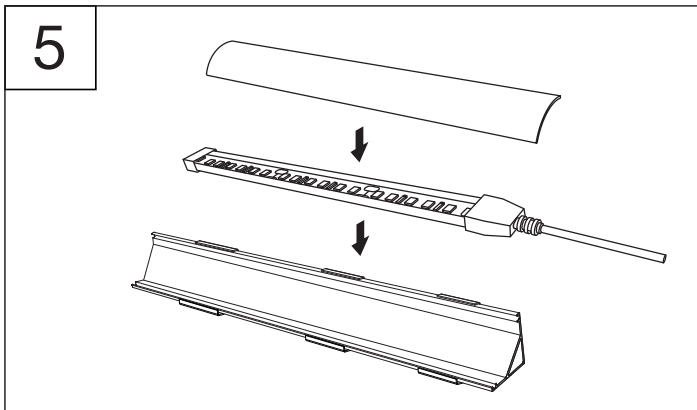
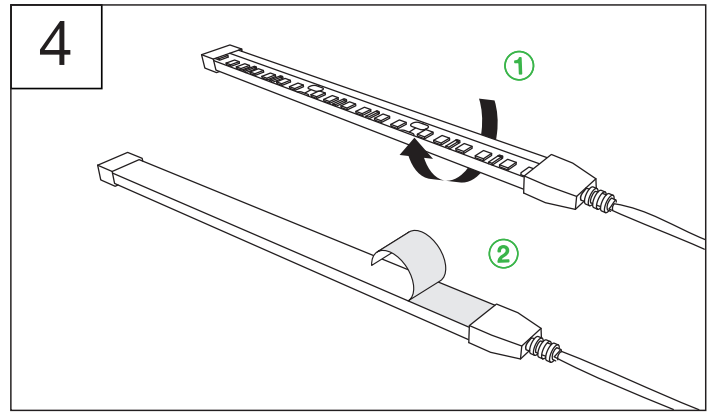
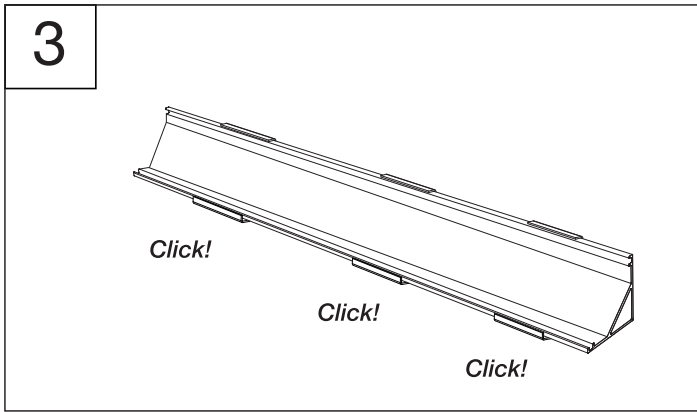



<p><b>EN</b></p> <ul style="list-style-type: none"> <li>-CONNECT TO THE POWER SUPPLY IN ACCORDANCE WITH NATIONAL REGULATIONS.</li> <li>-IF THE EXTERNAL FLEXIBLE CABLE OF THIS LUMINAIRE IS DAMAGED, IT SHALL BE EXCLUSIVELY REPLACED BY THE MANUFACTURER OR A SIMILAR QUALIFIED PERSON IN ORDER TO AVOID ANY HAZARD.</li> <li>-INSTALLATION/MAINTENANCE ONLY BY SKILLED PERSONNEL.</li> <li>-DURING OVERHAUL/MAINTENANCE ONLY USE ORIGINAL PARTS.</li> <li>-IF ANY LUMINAIRE IS SUBSEQUENTLY MODIFIED, THE PERSON RESPONSIBLE FOR THE MODIFICATION SHALL BE CONSIDERED THE MANUFACTURER.</li> <li>-THE MANUFACTURER BEARS NO LIABILITY FOR DAMAGE CAUSED BY INAPPROPRIATE USE OR APPLICATION.</li> <li>-THE PRODUCTS MUST ONLY BE SECURED USING THE PROVIDED BRACKETS, AND OTHER UNRELIABLE FIXATION METHODS (E.G. QUICK-DRYING ADHESIVE, ZIP TIE FASTENING) ARE STRICTLY PROHIBITED. ANY QUALITY ISSUES ARISING FROM THE USE OF UNAUTHORIZED FIXATION METHODS WILL NOT BE COVERED UNDER WARRANTY.</li> </ul>	<p><b>DE</b></p> <ul style="list-style-type: none"> <li>-NETZANSCHLUSS BITTE NACH DEN LÄNDERSPEZIFISCHEN ERRICHTUNGSBESTIMMUNGEN TÄTIGEN.</li> <li>-FALLS DAS EXTERNE FLEXIBLE KABEL DIESER LEUCHTE BESCHÄDIGT IST, DARF ES AUSSCHLIESSLICH ERSETZT WERDEN DURCH DEN HERSTELLER ODER EINER ÄHNLICH QUALIFIZIERTEN PERSON, UM GEFÄHRDUNGEN ZU VERMEIDEN.</li> <li>-MONTAGE/WARTUNG NUR DURCH FACHKRÄFTE.</li> <li>-BEI INSTANDSETZUNG/INSTANDHALTUNG NUR ORIGINALTEILE VERWENDEN.</li> <li>-WERDEN NACHTRÄGLICH ÄNDERUNGEN AN LEUCHTEN VORGENOMMEN, SO GILT DERJENIGE ALS HERSTELLER, DER DIESE ÄNDERUNG VORNIMMT.</li> <li>-DER HERSTELLER ÜBERNIMMT KEINE HAFTUNG FÜR SCHÄDEN, DIE DURCH UNSACHGEMÄSSEN EINSATZ ENTSTEHEN.</li> </ul>
<p><b>FR</b></p> <ul style="list-style-type: none"> <li>-CONNEXION À L'ALIMENTATION CONFORMÉMENT AUX NORMES EN VIGUEUR.</li> <li>-SI LE CÂBLE EXTÉRIEUR SOUPLE OU LE CORDON DE CE LUMINAIRE EST ENDOMMAGÉ, IL DOIT ÊTRE REMPLACÉ EXCLUSIVEMENT PAR LE FABRICANT, OU TOUTE PERSONNE DE QUALIFICATION ÉQUIVALENTE, CECI AFIN D'ÉVITER TOUT RISQUE.</li> <li>-LES OPERATIONS D'INSTALLATION ET D'ENTRETIEN DOIVENT ÊTRE EFFECTUÉES EXCLUSIVEMENT PAR DES PERSONNES QUALIFIÉES.</li> <li>-DANS LE CAS D'UNE REMISE EN ÉTAT, UTILISER UNIQUEMENT DES COMPOSANTS D'ORIGINE.</li> <li>-TOUTES MODIFICATIONS APPORTÉES AU LUMINAIRE SE FERONT SOUS LA RESPONSABILITÉ EXCLUSIVE DE CELUI QUI LES EFFECTUE.</li> <li>-LE FABRICANT DECLINE TOUTE RESPONSABILITÉ RESULTANT D'UN MISE EN OEUVRE INAPPROPRIÉE DU PRODUIT.</li> </ul>	<p><b>IT</b></p> <ul style="list-style-type: none"> <li>-EFFETTUARE L'ALLACCIAMENTO ALLA RETE SECONDO LE NORME DI INSTALLAZIONE VIGENTI NEL PAESE D'UTILIZZO.</li> <li>-SE IL CAVO FLESSIBILE ESTERNO DI QUESTO APPARECCHIO D'ILLUMINAZIONE È DANNEGGIATO, PER EVITARE PERICOLI ESSO PUÒ ESSERE SOSTITUITO ESCLUSIVAMENTE DAL PRODUTTORE O DA PERSONA DOTATA DI ADEGUATA QUALIFICA.</li> <li>-MONTAGGIO/MANUTENZIONE SOLO PER MEZZO DI PERSONALE SPECIALIZZATO.</li> <li>-PER RIPARAZIONE/MANUTENZIONE IMPIEGARE SOLO PARTI ORIGINALI.</li> <li>-IL COSTRUTTORE SI RISERVA IL DIRITTO DI APPORTARE SENZA PREAVVISO MODIFICHE DI PESO, DIMENSIONI E CARATTERISTICHE TECNICHE.</li> <li>-IL COSTRUTTORE NON È RESPONSABILE PER DANNI DERIVANTI DA MODIFICHE REALIZZATE DA TERZI E DA UNA INSTALLAZIONE NON CORRETTA.</li> </ul>
<p><b>ES</b></p> <ul style="list-style-type: none"> <li>-LA CONEXIÓN A RED DEBE DE REALIZARSE SIGUIENDO LAS NORMAS ESPECÍFICAS DE CADA PAÍSES.</li> <li>-EN CASO DE QUE EL CABLE EXTERNO FLEXIBLE DE ESTA LUMINARIA ESTE DAÑADO SÓLO PUEDE REEMPLAZARSE POR EL FABRICANTE O UNA PERSONA SIMILAR CUALIFICADA, PARA EVITAR PELIGROS.</li> <li>-EL MONTAJE Y MANTENIMIENTO LO EFECTUARÁN ÚNICAMENTE LOS TÉCNICOS ESPECIALIZADOS.</li> <li>-PARA REPARACIONES HAN DE EMPLEARSE SOLO PIEZAS ORIGINALES DE RECAMBIO.</li> <li>-RESERVADO EL DERECHO DE MODIFICACION DE DIMENSIONES, PESOS Y CARACTERÍSTICAS TÉCNICAS, SIN PREVIO AVISO.</li> <li>-EL FABRICANTE NO ASSUME RESPONSABILIDAD POR MODIFICACIONES REALIZADAS POR TERCEROS, NIP OR INSTALACION INCORRECTA.</li> </ul>	<p><b>PT</b></p> <ul style="list-style-type: none"> <li>-LIGAR À FONTE DE ALIMENTAÇÃO, DE ACORDO COM A REGULAMENTAÇÃO NACIONAL.</li> <li>-CASO O CABO EXTERNO E FLEXÍVEL DA LUMINÁRIA SE DANIFIQUE, DEVE SER SUBSTITUÍDO PELO FABRICANTE OU PESSOA IGUALMENTE QUALIFICADA, PARA EVITAR SITUAÇÕES DE PERIGO.</li> <li>-MONTAGEM/MANUTENÇÃO EFECTUADA UNICAMENTE POR PESSOAL TÉCNICO ESPECIALIZADO.</li> <li>-UTILIZAR SOMENTE PEÇAS ORIGINAIS DO FABRICANTE.</li> <li>-O FABRICANTE NÃO SE RESPONSABILIZA POR DANOS RESULTANTES DA INADEQUADA UTILIZAÇÃO DOS MATERIAIS.</li> </ul>
<p><b>EL</b></p> <ul style="list-style-type: none"> <li>-ΗΣΥΝΔΕΣΗ ΜΕ ΤΗΝ ΠΑΡΟΧΗ ΡΕΥΜΑΤΟΣ ΝΑ ΓΙΝΕΤΑΙ ΣΥΜΦΩΝΑ ΜΕ ΤΙΣ ΕΘΝΙΚΕΣ ΠΡΟΔΙΑΓΡΑΦΕΣ.</li> <li>-ΣΕ ΠΕΡΙΠΤΩΣΗ ΠΟΥ ΤΟ ΕΞΩΤΕΡΙΚΟ ΕΥΚΑΜΠΤΟ ΚΑΛΩΔΙΟ ΑΥΤΟΥ ΤΟΥ ΦΩΤΙΣΤΙΚΟΥ ΕΙΝΑΙ ΚΑΤΕΣΤΡΑΜΜΕΝΟ, ΠΡΕΠΕΙ ΝΑ ΑΝΤΙΚΑΤΑΣΤΑΘΕΙ ΑΠΟΚΛΕΙΣΤΙΚΑ ΚΑΙ ΜΟΝΟ ΑΠΟ ΤΟΝ ΚΑΤΑΣΚΕΥΑΣΤΗ Η ΑΠΟ ΑΛΛΟ ΕΞΟΥΣΙΟΔΟΤΗΜΕΝΟ ΑΤΟΜΟ, ΓΙΑ ΤΗΝ ΑΠΟΦΥΓΗ ΚΙΝΔΥΝΩΝ.</li> <li>-ΤΟΠΟΘΕΤΗΣΗ/ΣΥΝΤΗΡΗΣΗ ΜΟΝΟ ΑΠΟ ΗΛΕΚΤΡΟΛΟΓΟ.</li> <li>-ΚΑΤΑ ΤΗΝ ΕΠΙΣΚΕΥΗ/ΔΙΑΤΗΡΗΣΗ ΧΡΗΣΙΜΟΠΟΙΕΙΤΕ ΓΗΝΣΙΑ ΑΝΤΑΛΛΑΚΤΙΚΑ ΜΟΝΟ.</li> </ul>	<p><b>NL</b></p> <ul style="list-style-type: none"> <li>-AANSLUITEN OP HET LICHTNET, CONFORM DE NATIONALE REGELGEVING.</li> <li>-ALS HET EXTERNE FLEXIBELE SNOER VAN DEZE ARMATUUR BESCHADIGD IS, MAG DIT UITSLUITEND WORDEN VERVANGEN DOOR DE FABRIKANT OF EEN ANDERE GEKWALIFICEERDE PERSOON, OM RISICO'S TE VOORKOMEN.</li> <li>-MONTAGE/SERVICE ALLEEN DOOR VAKKUNDIG PERSONEEL.</li> <li>-BIJ INBEDRIJFSTELLEN/ONDERHOUD ALLEEN ORIGINELE ONDERDELEN GEBRUIKEN.</li> </ul>
<p><b>SV</b></p> <ul style="list-style-type: none"> <li>-NÅTANSLUTNING SKALL SKE ENLIGT NATIONELLA BESTÄMMELSER.</li> <li>-ÅR DEN EXTERNA FLEXIBLA SLADDEN PÅ LAMPAN SKADAD, FÅR ENDAST TILLVERKAREN ELLER EN ANNAN PERSON MED LIKANDE KVALIFIKATIONER BYTA UT DENNA, FÖR ATT UNDVIKA FAROR.</li> <li>-MONTERING AKÖTSEL ENDAAT AV FACKFOLK.</li> <li>-ANVÄND BARA ORIGINALDELAR VID IGGÅNGÅTTNING/UNDERHÅLL.</li> </ul>	<p><b>NO</b></p> <ul style="list-style-type: none"> <li>-KOBLE TIL STRØMFORSYNINGEN I HENHOLD TIL NASJONALE BESTEMMELSER.</li> <li>-HVIS DEN EKSTERNE OG FLEKSIBLE KABELN TIL DENNE LAMPEN ER SKADET, SÅ MÅ DEN KUN SKIFTES UT AV PRODUSENTEN ELLER EN LIKEVERDIG KVALISERT PERSON, FOR AT SKADER UNNGÅS.</li> <li>-MONTERES KUN AV FAGPERONELL.</li> <li>-VED FEILRETNING : BRUK KUN ORIGINALDELER.</li> </ul>
<p><b>CZ</b></p> <ul style="list-style-type: none"> <li>-PŘIPOJENÍ K SÍŤOVÉMU NAPĚTÍ DLE PLATNÝCH NÁRODNÍCH NOREM.</li> <li>-POKUD JE EXTERNÍ PRUŽNÝ KABEL TOHOTO SVĚTLIDLA POŠKOZEN, SMÍ JEHO VÝMĚNU PROVĚST POUZE VÝROBCE NEBO PODOBNĚ KVALIFIKOVANÁ OSOBA, ABY NEDOŠLO K ŽÁDNÉMU OHROŽENÍ.</li> <li>-MONTÁŽ A ÚDRŽBA MŮŽE BÝT PROUZITOU YJEN HRADNĚ odbornou osobou.</li> <li>-PŘI ÚDRŽBĚ NEBO OPRAVĚ MUSÍ BÝT POUŽITY JEN ORIGINALNÍ NÁHRADNÍ DÍLY.</li> </ul>	<p><b>RU</b></p> <ul style="list-style-type: none"> <li>-ВЫПОЛНИТЬ ПОДКЛЮЧЕНИЕ К СЕТИ В СООТВЕТСТВИИ С ПРИНЯТЫМИ В ДАННОЙ СТРАНЕ ПРАВИЛАМИ МОНТАЖА.</li> <li>-В СЛУЧАЕ ПОВРЕЖДЕНИЯ ВНЕШНЕГО ГИБКОГО КАБЕЛЯ ЭТОГО СВЕТИЛЬНИКА, ЧТОБЫ ИСКЛЮЧИТЬ РИСК, ОН ДОЛЖЕН БЫТЬ ЗАМЕНЕН ТОЛЬКО ИЗГОТОВИТЕЛЕМ ИЛИ ЛИЦОМ, ИМЕЮЩИМ ТАКУЮ ЖЕ КВАЛИФИКАЦИЮ.</li> <li>-ПРИ РЕМОНТЕ ПРИМЕНЯТЬ ТОЛЬКО ТЕЖЕ САМЫЕ ЧАСТИ.</li> <li>-МОНТАЖ/ОБСЛУЖИВАНИЕ ТОЛЬКО СПЕЦИАЛИСТАМИ.</li> </ul>
<p><b>HU</b></p> <ul style="list-style-type: none"> <li>-CSATLAKOZTASSA A TÁPEGYSÉGBE A HELYI ELŐÍRÁSOKNAK MEGFELELTŐEN.</li> <li>-HA EZEN LÁMPÁK HAJLÍTHATÓ/RUGALMAS KÁBELEI MEGSÉRÜLNÉK, AKKOR AZOK KIZÁRÓLAG CSAK A GYÁRTO VAGY HASONLÓAN KVALIFIKÁLT SZEMÉLY ÁLTAL CSERÉLHETŐK KI, HOGY ELKERÜLJÜK A BALESETEKET.</li> <li>-A SZERELÉST/KARBANTÁRTAST CSAK SZAKSZEMÉLYZET VÉGEZHETI.</li> <li>-ÜZEMBEHELYEZÉSNEK/KARBANTARTÁSNAK CSAK EREDETI ALKATRÉSZEK HASZNÁLHATÓK.</li> </ul>	<p><b>PL</b></p> <ul style="list-style-type: none"> <li>-ZASILANIE NALEŻY POŁĄCZYĆ ZGODNIE Z WYMAGANIAM I ODPOWIEDNICH NORM.</li> <li>-W PRZYPADKU USZKODZENIA PRZEWODU ZASILAJĄCEGO NALEŻY GO WYMIENIĆ NA NOWY. WYMIANA PRZEWODU MOŻE BYĆ WYKONANA JEDYNI PRZEZ WYKWALIFIKOWANEGO ELEKTRYKA.</li> <li>-MONTAŻ/KONSERWACJA TYLKO PRZEZ FACHOWY PERSONAL.</li> <li>-DLA NAPRAWY/BIEŻĄCEJ EKSPLOATACJI STOSOWAĆ TYLKO ORYGINALNE CZĘŚCI ZAMIENNE.</li> </ul>
<p><b>SK</b></p> <ul style="list-style-type: none"> <li>-ZAPOJTE DO EL. PRÍVODU PODĽA PREDPÍSANÝCH NORIEM.</li> <li>-AK JE EXTERNÝ PRUŽNÝ KÁBEL TOHTO SVETIDLA POŠKODENÝ, SMIE BYŤ NAHRADENÝ VÝLUČNE VÝROBCOM ALEBO PODOBNE KVALIFIKOVANOU OSOBOU, ABY SA ZABRÁNILO OHROZENIU.</li> <li>-MONTÁŽ/VZDRŽEVANJE LAHKO IZVRŠÍ JE USTREZNO USPOSOBLJENA OSEBA.</li> <li>-PRI POPRAVILU/VZDRŽEVALNIH DELIH SE LAHKO UPORABLJAJO SAMO ORIGINALNI DELI.</li> <li>-V KOLIKOR SE NA SVETILKAH NAKNADNO IZVEDEJO SPREMEMBE, SE ZA PROIZVAJALCA SVETILKE SMATRA TISTI, KI JE IZVEDEL SPREMEMBO.</li> <li>-PROIZVAJALEC NE JAMČI ZA ŠKODO, KI BI NASTALA ZARADI NEPRAVILNE UPORABE.</li> </ul>	<p><b>TR</b></p> <ul style="list-style-type: none"> <li>-ŞEBEKE BAĞLANTISINI LÜTFEN ÜLKEYE ÖZGÜ KURULUM KURALLARI ÇERÇEVESİNDE YAPINIZ.</li> <li>-AVİZENİN (LUMINAIRE) HARİCİ ESNEK KABLOSUNUN HASAR GÖRMESİ DURUMUNDA, TEHLİKELERDEN KAÇINMAK ÜZERE BU SADECE ÜRETİCİ TARAFINDAN VEYA BENZERİ VASİFLİ KİŞİLER TARAFINDAN DEĞİŞTİRİLEBİLİR.</li> <li>-MONTAJ VE BAKIM SADECE YETKİLİ PERSONEL TARAFINDAN YAPILMALIDIR.</li> <li>-BAKIMDA SADECE ORJINAL PARÇALAR KULLANIMALIDIR.</li> </ul>
<p><b>HR</b></p> <ul style="list-style-type: none"> <li>-MOLIMO IZVRŠITE MREŽNI PRIKLJUČAK PREMA SPECIFIČNIM NACIONALNIM ODREDBAMA O NJEGOVOM IZVRŠENJU.</li> <li>-UKOLIKO JE EKSTERNI, FLEKSIBILNI KABEL TE SVJETILJKE OŠTEĆEN, ZAMJENA ISTOG JE DOZVOLJENA ISKLJUČIVO PROIZVOĐAČU ILI SLIČNOU KVALIFICIRANOJ OSOBI, KAKO BI SE IZBJEGLE OPASNOSTI.</li> <li>-MONTAŽ/ODRŽAVANJE MORA BIVŠITI ODGOVARAJUĆE OSPOSOBLJENA OSOBA.</li> <li>-PRI POPRAVKU/ODRŽAVANJU KORISTITI SAMO ORIGINALNE DIJELOVE.</li> <li>-UKOLIKO SE NA SVJETILJKAMA NAKNADNO VRŠE PROMJENE, ZA PROIZVOĐAČA SVJETILJKE SE SMATRA TAJ KOJI JE PROMJENE IZVRŠIO.</li> <li>-PROIZVOĐAČ NE GARANTUJE ZA ŠTETU KOJA BI MOGLA NASTATI USLED NEPRAVILNE UPOTREBE.</li> </ul>	<p><b>SR</b></p> <ul style="list-style-type: none"> <li>-MOLIMO DA MREŽNI PRIKLJUČAK PROVEDETE PREMA SPECIFIČNIM NACIONALNIM ODREDBAMA O NJEGOVOM PROVOĐENJU.</li> <li>-AKO JE EKSTERNI FLEKSIBILNI KABAL OVE SVETILJKE OŠTEĆEN, NJEGA SME DA ZAMENI ISKLJUČIVO PROIZVOĐAČ ILI NEKO SLIČNO KVALIFIKOVANO LIČE, DA BI SE IZBEGLA UGROŽAVANJA.</li> <li>-MONTAŽ/ODRŽA VANJE MOŽE DA OBAVI SAMO STRUČNO OSPOSOBLJENA OSOBA.</li> <li>-PRI POPRAVLJANJU/ODRŽAVANJU UPOTREBLJAVATI SAMO ORIGINALNE DELOVE.</li> <li>-UKOLIKO SE NA SVETILKAMA NAKNADNO URADE IZMENE, ZA PROIZVAĐAČA SVETILJKE ĆE SE SMATRATI ONAJ KO IZMENE IZVRŠIO.</li> <li>-PROIZVAĐAČ NE GARANTUJE ZA ŠTETU KOJA BI MOGLA NASTATI USLED NEPRAVILNE UPOTREBE.</li> </ul>