

# TRAXON Plus<sup>+</sup>

## Vista Plus HO Midi White



Project: \_\_\_\_\_

Type: \_\_\_\_\_



IP66



COAST



DMX/RDM



ANSI 3G



IK08



The Vista Plus HO Midi White is an AC line powered, high brightness luminaire. Controllable with DMX512, the Vista Plus HO Midi White is a new member of the Vista Plus family, offering 200W per head with 1-head, 2-head and 3-head options. The daisy chain topology, and direct-wire nature of the fixture via the two integral cable whips allow for simple installation into existing installations and new structures, and is ideal for high-rise and tower illumination.

### Features

- DMX / RDM control
- Easy installation and maintenance
- Assortment of optical and installation accessories

### Dimensions

Unit: mm

Vista Plus HO Midi 1x200W

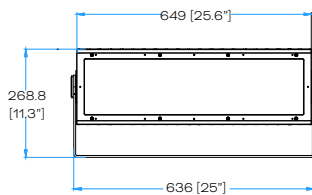

Vista Plus HO Midi 2x200W

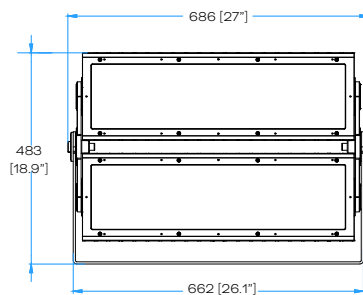

Vista Plus HO Midi 3x200W

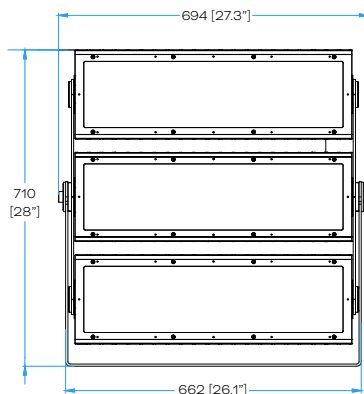

### Technologies

- Auto-Addressing / Manual Addressing
- DMX / RDM control

### Color Options

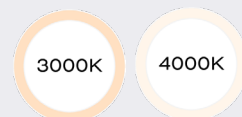

3000K / 4000K Std; 2700K, 3500K, 5700K, 6500K available DW on demand

### Beam Angles

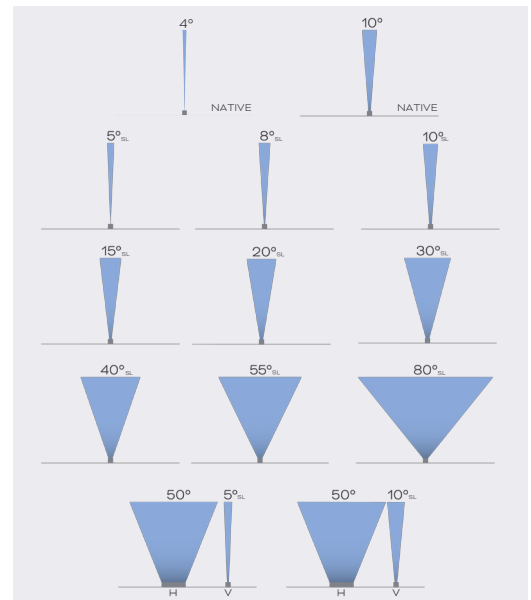

### Finish



Traxon Signature Gray RAL 7005

RAL 7015

RAL 9005

RAL 9003

Custom

### Product Specifications

Model	1 x 200W	2 x 200W	3 x 200W			
Light Source	White LED x 56	White LED x 112	White LED x 168			
Pixel	1 pixel per head, each head can be controlled individually					
Color Range	3000K / 4000K Std; 2700K, 3500K, 5700K, 6500K available DW on demand (e.g. 2700K+5700K)					
LED Quantity	White LED 56 pcs (DW on demand, 28pcs WW, 28pcs CW)	White LED 112 pcs (DW on demand, 56pcs WW, 56pcs CW)	White LED 168 pcs (DW on demand, 84pcs WW, 84pcs CW)			
Luminous Flux (4000K)	21000 lm (4° SW)	42000 lm (4° SW)	63000 lm (4° SW)			
Candela (4000K)	1135260 cd (4° SW)	2270520 cd (4° SW)	3405780 cd (4° SW)			
Efficacy (4000K)	105 lm/W (4° SW)					
CRI	90 CRI by request: 2700K-4000K (CRI90)					
Beam Angles	4° & 10° native <sup>1</sup> ; 5°, 8°, 10°, 15°, 20°, 30°, 40°, 55°, 80°, 50° x 10°, 50° x 5° via accessory					
Cover Lens	Tempered Glass					
Housing	Die Cast Aluminum					
Housing Finish Options	Standard color: Traxon Signature Gray (RAL7005) Optional color: Gray (RAL7015), Black (RAL9005), White (RAL9003), Custom					
Adjustment Options	1x200W: ±90° vertical 2x200W: ±30° vertical per head, see page 5 for additional information 3x200W: ±30° vertical per outer head, ±20° for center head, See page 6 for additional information					
Mounting	Surface Mount Optional mounting accessories are available					
Dimensions (W x D x H)	649mm x 286.8mm x 144mm / 25.6" x 11.3" x 5.7"	686mm x 483mm x 144.2mm / 27" x 18.9" x 5.7"	694mm x 710mm x 144mm / 27.3" x 28" x 5.7"			
Weight	14.5kg / 31.96lbs.	28.3 kg / 63 lbs.	44 kg / 97 lbs.			
EPA	Vista Plus 1x200W: Front: 1.02 Side: 0.42	Vista Plus 1x200W with Pole mount: Front: 1.3296 Side: 0.6576	Vista Plus 2x200W: Front: 1.032 Side: 0.9096	Vista Plus 2x200W with Pole mount: Front: 1.3392 Side: 1.1472	Vista Plus 3x200W: Front: 1.044 Side: 1.3932	Vista Plus 3x200W with Pole mount: Front: 1.351 Side: 1.632
Regulatory Listing & Safety Approval	cETLus, CE, UKCA, FCC, RoHS, REACH, ASTM B117-16, ANSI 3G					
Operating Temperature	-30°C to +55°C / -22°F to +131°F					
Minimum Starting Temperature	-20°C / -4°F					
Storage Temperature	-40°C to +80°C / -40°F to +176°F					
Environment	Outdoor, IP66, IK08, Coastal Environment (ASTM B117-16)					
Humidity	85%, non-condensing					

### Electrical Specifications

Operating Voltage <sup>2</sup>	120-277V AC 50/60Hz		
Power Consumption (W)	200	400	600
Lumen Maintenance	L70 @25°C 81,000hrs		
Power Factor	> 0.9		

### System Specifications

Power Supply	AC line
Control	DMX/RDM RDM personality: 16 bit 0-10V Dimming on demand (White only)
Addressing Options <sup>3</sup>	Auto-addressing ON or Auto-addressing OFF (Default as Auto-addressing OFF, address through RDM)

1. 4° native with actual measurement of avg. 4.8°.  
2. Auto-switching, Single phase (line, neutral and ground).  
3. Auto-addressing Off (i.e. Manual addressing) is as default.

LED CHARACTERISTICS Because LEDs are semiconductor devices, their performances are subject to inherent variability commonly found in semiconductor industry. To improve consistency in performance across the same product, LED manufacturers "sort" LEDs into bins according to different preset parameters, such as forward driving voltage, illumination, etc. Whereas binning is a sorting function, it is not a correction process. Inherent variability in the manufacturing process results always in different binning distributions according to different production lots. Traxon uses automatically binned LEDs on its products, thereby minimizing output variations within the model range.

As with all electronic devices, LED output degrades over time - a term called lumen depreciation. This also explains why it is nearly impossible to expect photometric performances of two LED products with different service life spans to be the same. The rate of LED degrade is a complicated function of many factors such as operating efficiency, duration of continuous operation, and more significantly, environmental conditions (ambient temperature for example). If allowed working under optimal operating temperature range and with good ventilation, LED devices enjoy long service lives over conventional light sources. When using/installing LED devices, care should be taken to ensure that the devices will operate within the operating conditions specified in respective product literature.

Lumen measurement complies with LM-79-08 standard.  
Lumen maintenance is calculated based on LM-80 compliant measurement.

### Source Specifications

Length Option	1x200W	2x200W	3x200W
Source	White LED 56 pcs	White LED 112 pcs	White LED 168 pcs
Optics	4°		

### Candela Distribution

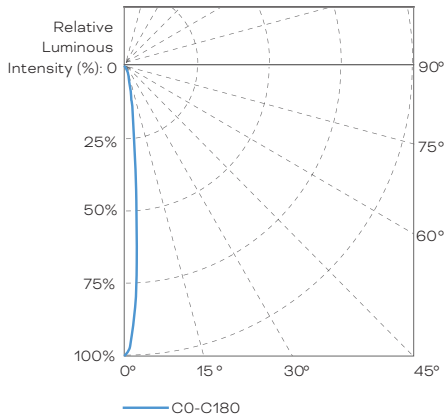

### Light Output

	Color	Luminous Flux (lm)	Center Intensity (cd)	Efficacy (lm/W)
1x200W	3000K	18480.0	999029	92.4
	4000k	21000.0	1135260	105.0
2x200W	3000K	36960.0	1998058	92.4
	4000k	42000.0	2270520	105.0
3x200W	3000K	55440.0	2997086	92.4
	4000k	63000.0	3405780	105.0

### Illuminance at a Distance

	Center Beam LUX/klm	Beam Width	
16m	240	1.34m / 4.40'	52.49'
32m	60	2.68m / 8.79'	104.99'
48m	27	4.02m / 13.19'	157.48'
64m	15	5.36m / 17.59'	209.97'
80m	10	6.71m / 22.01'	262.47'

● Horiz.Spread: 4.8°

For Foot-candle divide by 10.7

IES and LDT files are available for download from the Traxon website.

### Source Specifications

Length Option	1x200W	2x200W	3x200W
Source	White LED 56 pcs	White LED 112 pcs	White LED 168 pcs
Optics	10°		

### Candela Distribution

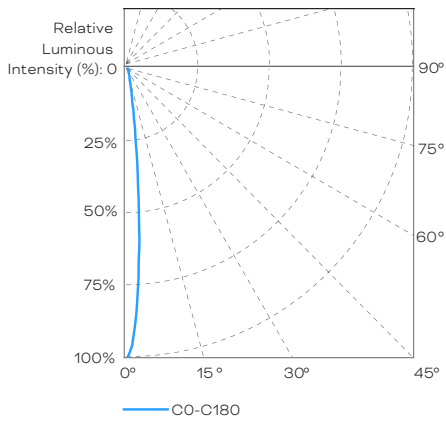

### Light Output

	Color	Luminous Flux (lm)	Center Intensity (cd)	Efficacy (lm/W)
1x200W	3000K	17001.6	449755	85.0
	4000k	19320.0	511085	96.6
2x200W	3000K	34003.2	899510	85.0
	4000k	38640.0	1022171	96.6
3x200W	3000K	51004.8	1349266	85.0
	4000k	57960.0	1533256	96.6

### Illuminance at a Distance

	Center Beam LUX/klm	Beam Width	
0.5m	96750	0.08m / 0.26'	1.64'
1m	24187	0.16m / 0.52'	3.28'
1.5m	10750	0.24m / 0.79'	4.92'
2m	6047	0.32m / 1.05'	6.56'
2.5m	3870	0.40m / 1.31'	8.2'
3m	2687	0.48m / 1.57'	9.84'

● Horiz.Spread: 9.2°

For Foot-candle divide by 10.7

IES and LDT files are available for download from the Traxon website.

	Power input cable	Data in / out cable (combined)
Cable Length (open wire)	1830mm [72"]	1830mm [72"]
Cable Outer Diameter	7.8mm [0.31"]	8.1mm [0.32"]

### Fixture - 1x200W

Unit: mm

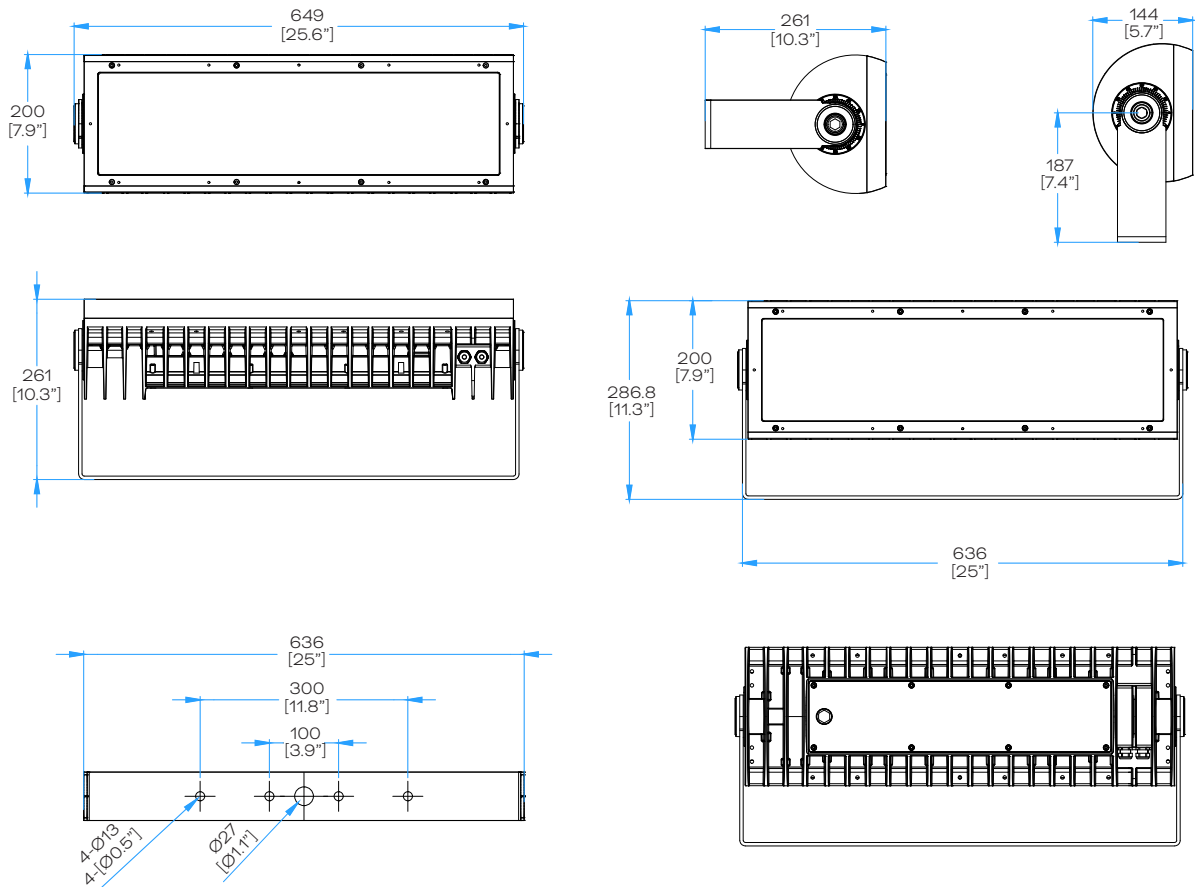

NOTE: Please see CAD files for additional dimensional data.

### Fixture - 2x200W

Unit: mm

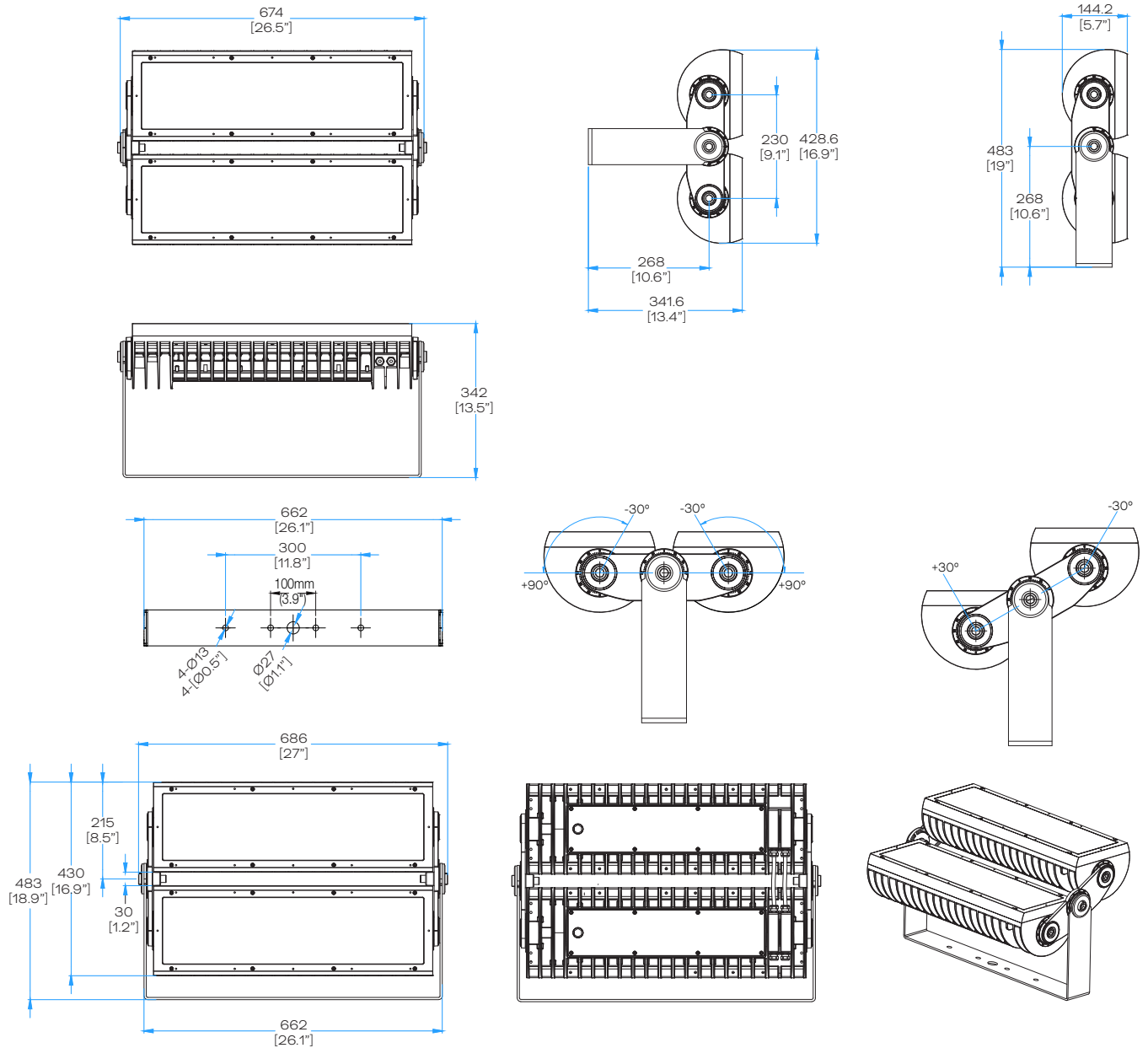

NOTE: Please see CAD files for additional dimensional data.

### Fixture - 3x200W

Unit: mm

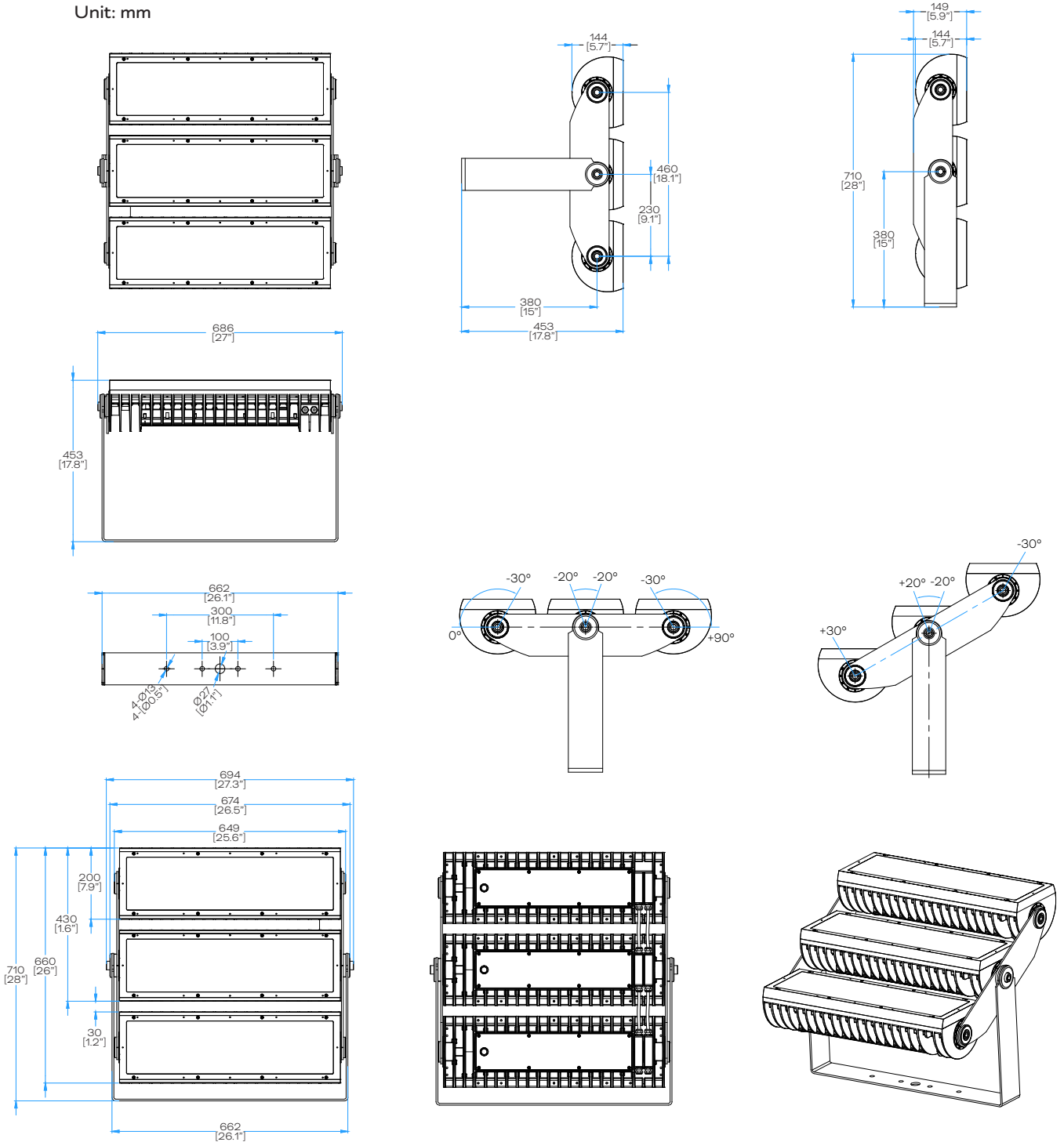

NOTE: Please see CAD files for additional dimensional data.

### Mounting Accessories

Model No.	Description	Item Code
N/A	VISTA PLUS POLE-MOUNTING SUPPORT	AM380750055
N/A	VISTA PLUS POLE-MOUNTING SUPPORT BL	AM380900055
N/A	VISTA PLUS POLE-MOUNTING SUPPORT WT	AM381050055

Unit: mm

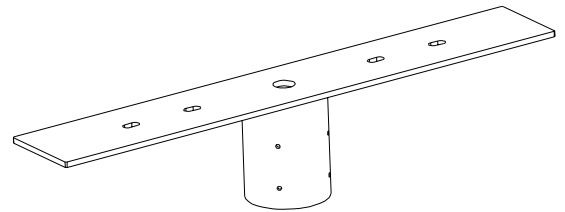
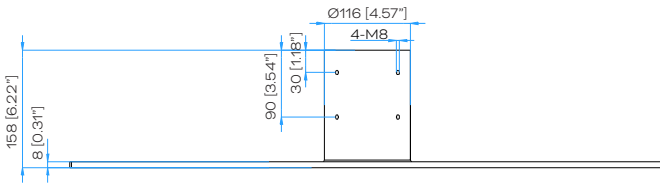
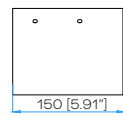
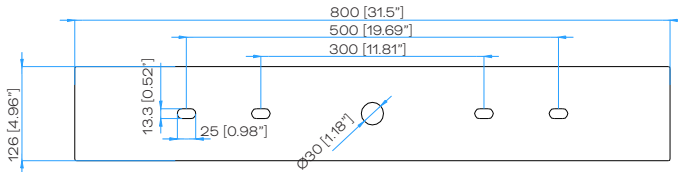

### Optical Accessories

#### Full Glare Shield

Model No.	Description	Item Code
N/A	VISTA PLUS 100W FULL SHIELD	AM410310055
N/A	VISTA PLUS 100W FULL SHIELD BL	AM410450055
N/A	VISTA PLUS 100W FULL SHIELD WT	AM410590055

Unit: mm

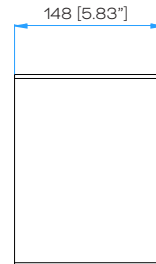
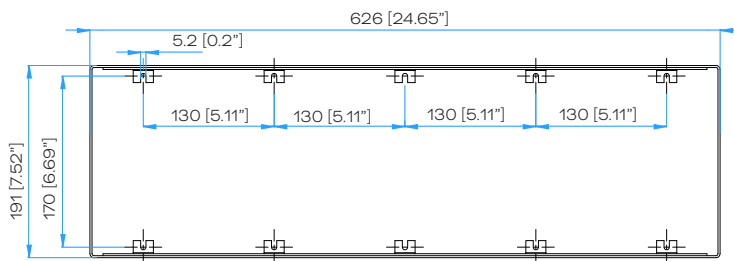

### Optical Accessories

#### Half Glare Shield

Model No.	Description	Item Code
N/A	VISTA PLUS 100W HALF SHIELD	AM410300055
N/A	VISTA PLUS 100W HALF SHIELD BL	AM410440055
N/A	VISTA PLUS 100W HALF SHIELD WT	AM410580055

Unit: mm

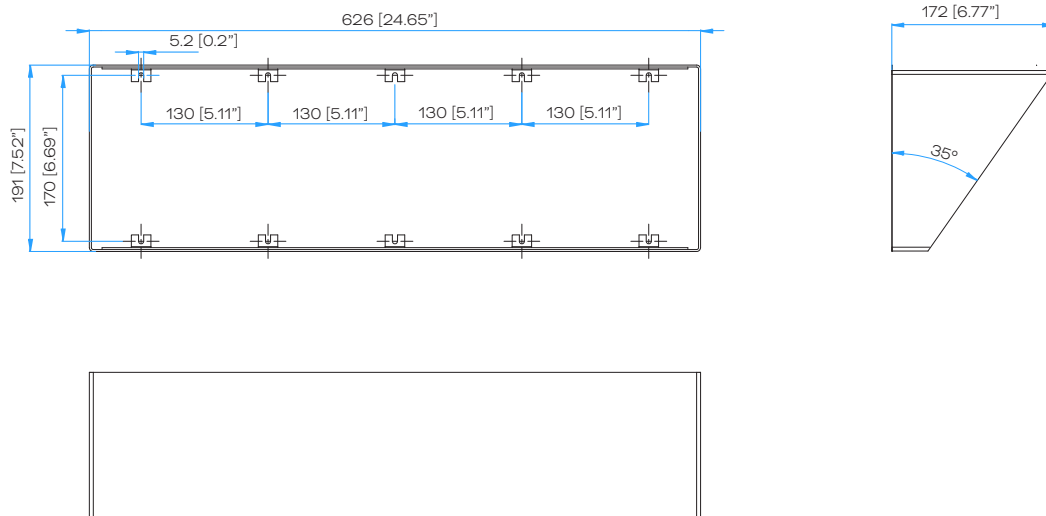

#### Rock Guard

Model No.	Description	Item Code
N/A	VISTA PLUS 100W ROCK GUARD	AM410320055
N/A	VISTA PLUS 100W ROCK GUARD BL	AM410460055
N/A	VISTA PLUS 100W ROCK GUARD WT	AM410600055

Unit: mm

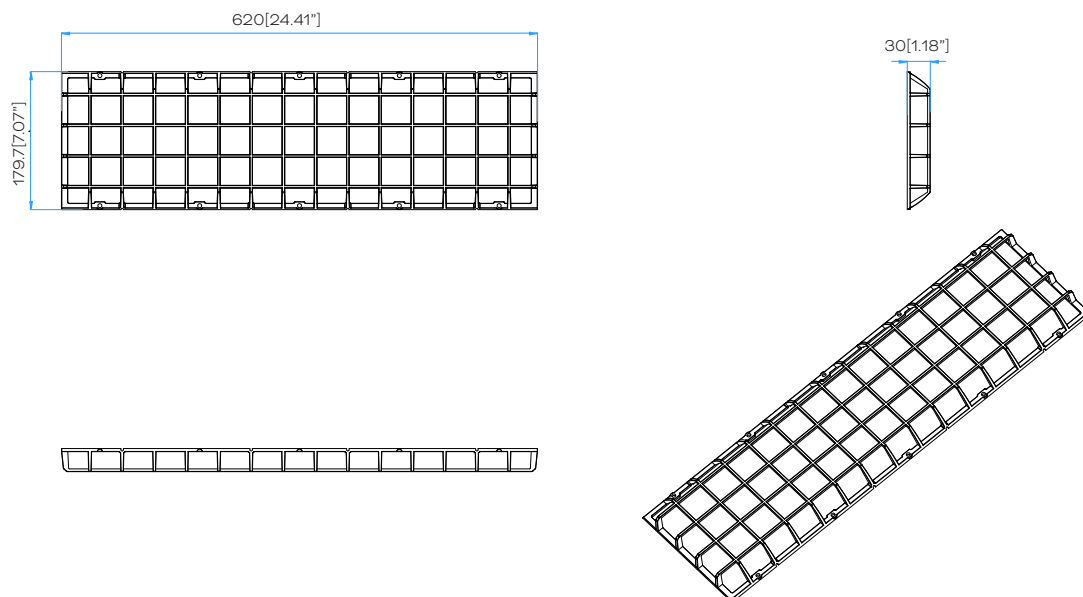

NOTE: Please see CAD files for additional dimensional data.

### Optical Accessories

#### Spread Lens Module

Model No.	Description	Item Code
N/A	VISTA PLUS 100W SPREAD MODULE 5 / 5 BL/ 5 WT	AM410330055 / AM410470055 / AM410610055
N/A	VISTA PLUS 100W SPREAD MODULE 8 / 8 BL/ 8 WT	AM410340055 / AM410480055 / AM410620055
N/A	VISTA PLUS 100W SPREAD MODULE 10 / 10 BL/ 10 WT	AM410350055 / AM410490055 / AM410630055
N/A	VISTA PLUS 100W SPREAD MODULE 15 / 15 BL/ 15 WT	AM410360055 / AM410500055 / AM410640055
N/A	VISTA PLUS 100W SPREAD MODULE 20 / 20 BL/ 20 WT	AM410370055 / AM410510055 / AM410650055
N/A	VISTA PLUS 100W SPREAD MODULE 30 / 30 BL/ 30 WT	AM410380055 / AM410520055 / AM410660055
N/A	VISTA PLUS 100W SPREAD MODULE 40 / 40 BL/ 40 WT	AM410390055 / AM410530055 / AM410670055
N/A	VISTA PLUS 100W SPREAD MODULE 55 / 55 BL/ 55 WT	AM410400055 / AM410540055 / AM410680055
N/A	VISTA PLUS 100W SPREAD MODULE 80 / 80 BL/ 80 WT	AM410410055 / AM410550055 / AM410690055
N/A	VISTA PLUS 100W SPREAD MODULE 50X10 / 50X10 BL/ 50X10 WT	AM410420055 / AM410560055 / AM410700055
N/A	VISTA PLUS 100W SPREAD MODULE 50X5 / 50X5 BL/ 50X5 WT	AM410430055 / AM410570055 / AM410710055

Unit: mm

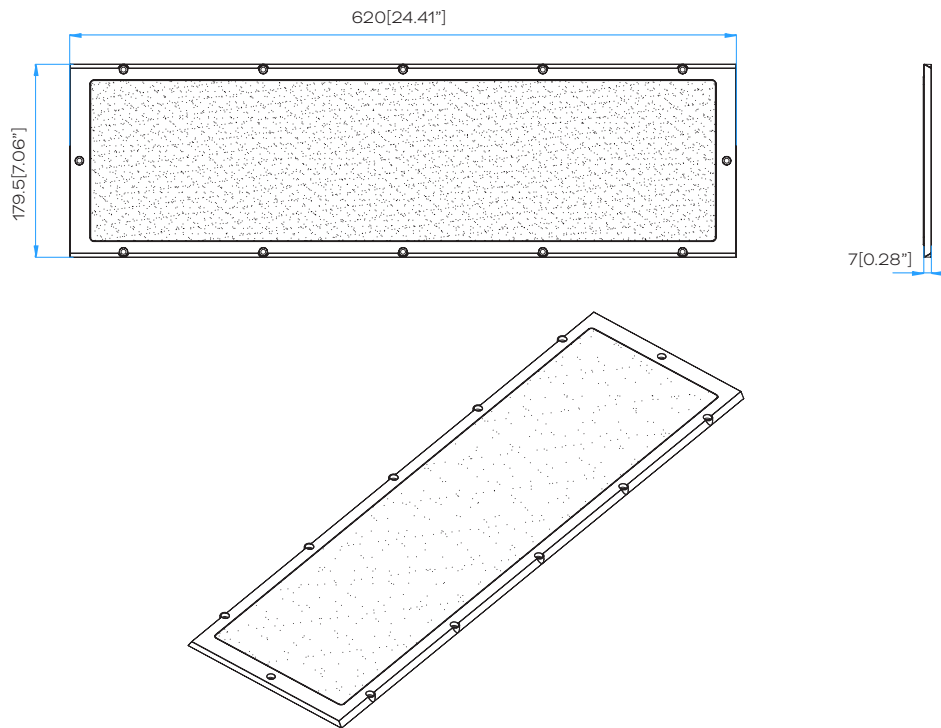

NOTE: Please see CAD files for additional dimensional data.

### Wiring Diagram - 1x200W

- Vista Plus fixtures ship with two cable whips: One cable whip for power input, consisting of two wires plus a ground, and one cable whip for DMX512 RDM input/output.
- No more than (32) fixtures on a single DMX512 link, max. 100m total (source to last fixture). Each fixture has 1.8m DMX data cable (total 3.6m DMX in and DMX out), it should be included in the 100m total calculation.
- Each DMX512 link must be properly terminated to prevent signal reflections.
- Data cabling from DMX source to first fixture and between subsequent Vista Plus fixtures shall be Cat5e UTP or higher (stranded type only) or other cable type suitable for DMX communication. Consult DMX standard for additional guidance.

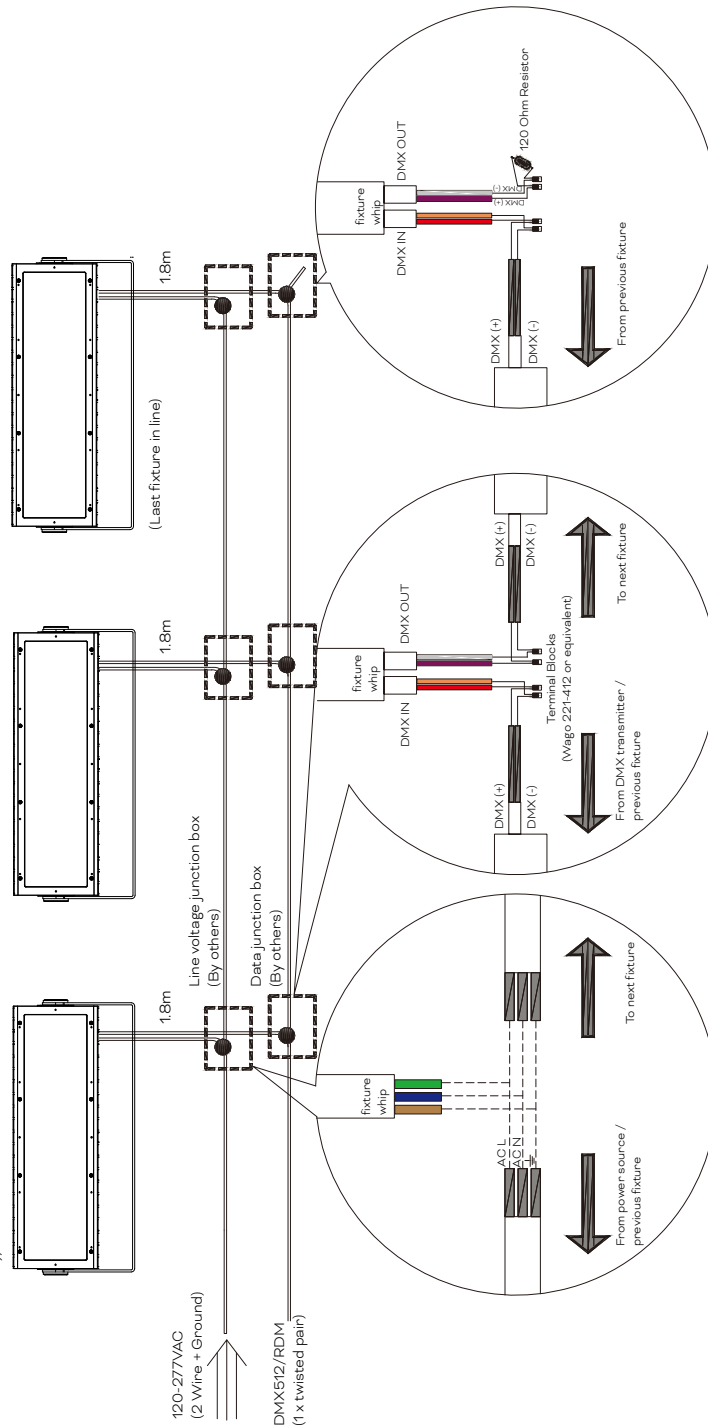

#### General Notes

- All data cabling must adhere to ANSI E1.11-2008 (R2013) - Entertainment Technology - USITT DMX512-A, Asynchronous Serial Digital Data Transmission Standard for Controlling Lighting Equipment and Accessories.
- Fixture is RDM compatible.
- Fixtures allow a universal input of 120V AC to 277V AC.
- Data termination shall utilize cage clamp terminal blocks, or equivalent. Wire nuts are not permissible and will void warranty.
- The method of line voltage termination, both for data and power, is at the discretion of the installing contractor, and/or engineer. Splicing and/or joining of cables must adhere to all applicable electrical codes.
- Cables must be spliced/joined in a weatherproof enclosure/junction box, which is to be properly rated and provided by others.

### Wiring Diagram - 2x200W

- Vista Plus fixtures ship with two cable whips: One cable whip for power input, consisting of two wires plus a ground, and one cable whip for DMX512 RDM input/output.
- No more than (32) fixtures on a single DMX512 link, max. 100m total (source to last fixture). Each fixture has 1.8m DMX data cable (total 3.6m DMX in and DMX out), it should be included in the 100m total calculation.
- Each DMX512 link must be properly terminated to prevent signal reflections.
- Data cabling from DMX source to first fixture and between subsequent Vista Plus fixtures shall be Cat5e UTP or higher (stranded type only) or other cable type suitable for DMX communication. Consult DMX standard for additional guidance.

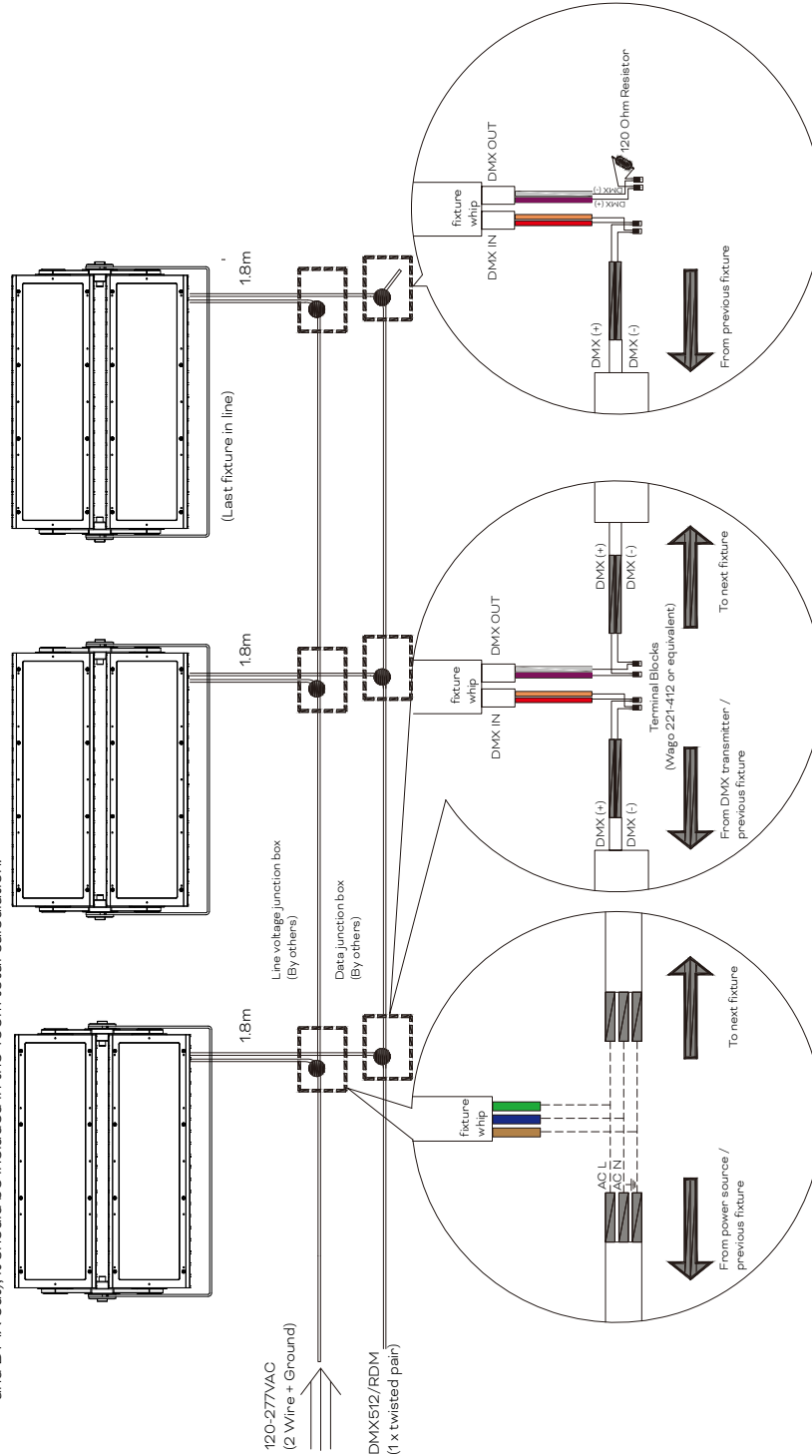

#### General Notes

- All data cabling must adhere to ANSI/E111-2008 (R2013) – Entertainment Technology – USITT DMX512-A, Asynchronous Serial Digital Data Transmission Standard for Controlling Lighting Equipment and Accessories.
- Fixture is RDM compatible.
- Fixtures allow a universal input of 120V AC to 277V AC.
- Data termination shall utilize cage clamp terminal blocks, or equivalent. Wire nuts are not permissible and will void warranty.
- The method of line voltage termination, both for data and power, is at the discretion of the installing contractor, and/or engineer. Splicing and/or joining of cables must adhere to all applicable electrical codes.
- Cables must be spliced/joined in a weatherproof enclosure/junction box, which is to be properly rated and provided by others.

### Wiring Diagram - 3x200W

- Vista Plus fixtures ship with two cable whips: One cable whip for power input, consisting of two wires plus a ground, and one cable whip for DMX512 RDM input/output.
- No more than (32) fixtures on a single DMX512 link, max. 100m total (source to last fixture). Each fixture has 1.8m DMX data cable (total 3.6m DMX in and DMX out), it should be included in the 100m total calculation.
- Each DMX512 link must be properly terminated to prevent signal reflections.
- Data cabling from DMX source to first fixture and between subsequent Vista Plus fixtures shall be Cat5e UTP or higher (stranded type only) or other cable type suitable for DMX communication. Consult DMX standard for additional guidance.

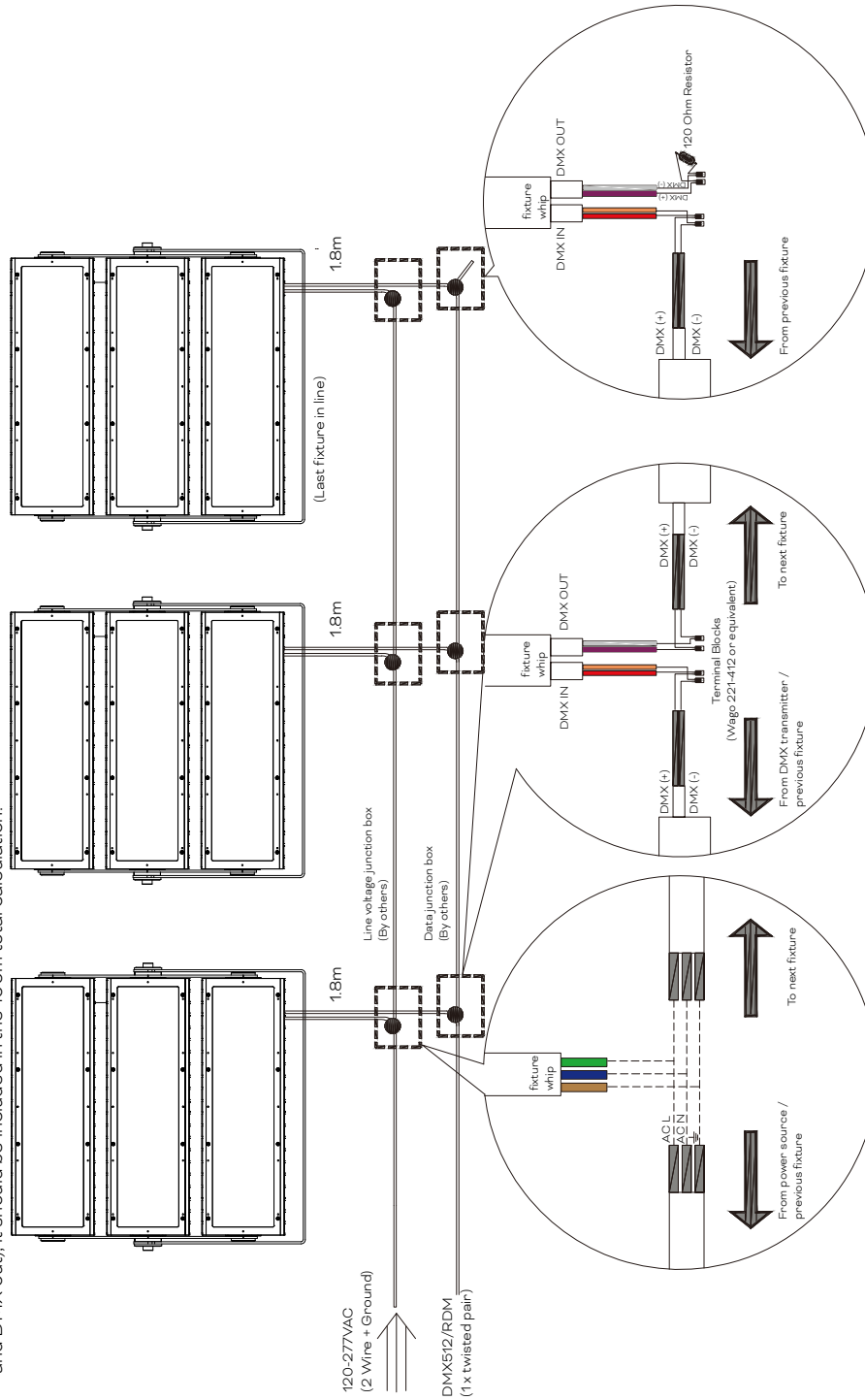

#### General Notes

- All data cabling must adhere to ANSI E11-2008 (R2013) – Entertainment Technology – USITT DMX512-A, Asynchronous Serial Digital Data Transmission Standard for Controlling Lighting Equipment and Accessories.
- Fixture is RDM compatible.
- Fixtures allow a universal input of 120V AC to 277V AC.
- Data termination shall utilize cage clamp terminal blocks, or equivalent. Wire nuts are not permissible and will void warranty.
- The method of line voltage termination, both for data and power, is at the discretion of the installing contractor, and/or engineer. Splicing and/or joining of cables must adhere to all applicable electrical codes.
- Cables must be spliced/joined in a weatherproof enclosure/junction box, which is to be properly rated and provided by others.

### Model Number Builder

VI.	PL.	N	2	2	N	N	1	1	1	1	N	0	0
		Number of Head	Wattage per head	LED	CCT	Optics	Control	Pixel	Approbation	Mounting/ Add On	Color Finish	Cable/ Connector	
		1: 1-head	2 - 200W AC per Midi head	2 - White	4 - 3000K	2 - 4°	1 - DMX/RDM	1 - 1 pixel per head	1 - CE & ETL	1 - 3G vibration	0 - TX Signature Gray	0 - Standard version	
		2: 2-head			5 - 4000K	3 - 10°					1 - Gray		
		3: 3-head			6 - 5700K						2 - Black		
					7 - 6500K						3 - White		
					8 - DW2757 (2700K + 5700K)								

**EXAMPLE** VISTA PLUS HO MIDI 1x200W AC WHITE 3000K 4° TX-GRAY CE  
Model Number: VI.PL.12242111100

VI.	PL.	1	2	2	4	2	1	1	1	1	1	0	0
-----	-----	---	---	---	---	---	---	---	---	---	---	---	---

### Project Model Number

VI.	PL.		2	2			1	1	1	1		0	0
-----	-----	--	---	---	--	--	---	---	---	---	--	---	---

### Fixture

Model No.	Description	Item Code
VI.PL.12242111100	VISTA PLUS HO MIDI 1x200W AC 3000K 4° TX-GRAY	DL26103656955
VI.PL.12252111100	VISTA PLUS HO MIDI 1x200W AC 4000K 4° TX-GRAY	DL26103657055
VI.PL.22242111100	VISTA PLUS HO MIDI 2x200W AC 3000K 4° TX-GRAY	DL26103657455
VI.PL.22252111100	VISTA PLUS HO MIDI 2x200W AC 4000K 4° TX-GRAY	DL26103657555
VI.PL.32242111100	VISTA PLUS HO MIDI 3x200W AC 3000K 4° TX-GRAY	DL26103657955
VI.PL.32252111100	VISTA PLUS HO MIDI 3x200W AC 4000K 4° TX-GRAY	DL26103658055
VI.PL.12243111100	VISTA PLUS HO MIDI 1x200W AC 3000K 10° TX-GRAY	DL26103659455
VI.PL.12253111100	VISTA PLUS HO MIDI 1x200W AC 4000K 10° TX-GRAY	DL26103659555
VI.PL.22243111100	VISTA PLUS HO MIDI 2x200W AC 3000K 10° TX-GRAY	DL26103659955
VI.PL.22253111100	VISTA PLUS HO MIDI 2x200W AC 4000K 10° TX-GRAY	DL26103660055
VI.PL.32243111100	VISTA PLUS HO MIDI 3x200W AC 3000K 10° TX-GRAY	DL26103660455
VI.PL.32253111100	VISTA PLUS HO MIDI 3x200W AC 4000K 10° TX-GRAY	DL26103660555

### Mounting Accessories

Model No.	Description	Item Code
N/A	VISTA PLUS POLE-MOUNTING SUPPORT	AM380750055
N/A	VISTA PLUS POLE-MOUNTING SUPPORT BL	AM380900055
N/A	VISTA PLUS POLE-MOUNTING SUPPORT WT	AM381050055
N/A	PROPOINT TERMINATION KIT	AM243520054

### Optical Accessories

Model No.	Description	Item Code
N/A	VISTA PLUS 100W HALF SHIELD	AM410300055
N/A	VISTA PLUS 100W FULL SHIELD	AM410310055
N/A	VISTA PLUS 100W ROCK GUARD	AM410320055
N/A	VISTA PLUS 100W SPREAD MODULE 5	AM410330055
N/A	VISTA PLUS 100W SPREAD MODULE 8	AM410340055

### Optical Accessories

Model No.	Description	Item Code
N/A	VISTA PLUS 100W SPREAD MODULE 10	AM410350055
N/A	VISTA PLUS 100W SPREAD MODULE 15	AM410360055
N/A	VISTA PLUS 100W SPREAD MODULE 20	AM410370055
N/A	VISTA PLUS 100W SPREAD MODULE 30	AM410380055
N/A	VISTA PLUS 100W SPREAD MODULE 40	AM410390055
N/A	VISTA PLUS 100W SPREAD MODULE 55	AM410400055
N/A	VISTA PLUS 100W SPREAD MODULE 80	AM410410055
N/A	VISTA PLUS 100W SPREAD MODULE 50X10	AM410420055
N/A	VISTA PLUS 100W SPREAD MODULE 50X5	AM410430055
N/A	VISTA PLUS 100W HALF SHIELD BL	AM410440055
N/A	VISTA PLUS 100W FULL SHIELD BL	AM410450055
N/A	VISTA PLUS 100W ROCK GUARD BL	AM410460055
N/A	VISTA PLUS 100W SPREAD MODULE 5 BL	AM410470055
N/A	VISTA PLUS 100W SPREAD MODULE 8 BL	AM410480055
N/A	VISTA PLUS 100W SPREAD MODULE 10 BL	AM410490055
N/A	VISTA PLUS 100W SPREAD MODULE 15 BL	AM410500055
N/A	VISTA PLUS 100W SPREAD MODULE 20 BL	AM410510055
N/A	VISTA PLUS 100W SPREAD MODULE 30 BL	AM410520055
N/A	VISTA PLUS 100W SPREAD MODULE 40 BL	AM410530055
N/A	VISTA PLUS 100W SPREAD MODULE 55 BL	AM410540055
N/A	VISTA PLUS 100W SPREAD MODULE 80 BL	AM410550055
N/A	VISTA PLUS 100W SPREAD MODULE50X10 BL	AM410560055
N/A	VISTA PLUS 100W SPREAD MODULE50X5 BL	AM410570055
N/A	VISTA PLUS 100W HALF SHIELD WT	AM410580055
N/A	VISTA PLUS 100W FULL SHIELD WT	AM410590055
N/A	VISTA PLUS 100W ROCK GUARD WT	AM410600055
N/A	VISTA PLUS 100W SPREAD MODULE 5 WT	AM410610055
N/A	VISTA PLUS 100W SPREAD MODULE 8 WT	AM410620055
N/A	VISTA PLUS 100W SPREAD MODULE 10 WT	AM410630055
N/A	VISTA PLUS 100W SPREAD MODULE 15 WT	AM410640055
N/A	VISTA PLUS 100W SPREAD MODULE 20 WT	AM410650055
N/A	VISTA PLUS 100W SPREAD MODULE 30 WT	AM410660055
N/A	VISTA PLUS 100W SPREAD MODULE 40 WT	AM410670055
N/A	VISTA PLUS 100W SPREAD MODULE 55 WT	AM410680055
N/A	VISTA PLUS 100W SPREAD MODULE 80 WT	AM410690055
N/A	VISTA PLUS 100W SPREAD MODULE50X10 WT	AM410700055
N/A	VISTA PLUS 100W SPREAD MODULE50X5 WT	AM410710055

Note: Vista Plus 100W accessory is suitable for Vista Plus Midi / Vista Plus HO Midi.