

TRAXON Plus⁺

Vista Plus Maxi White

Project: _____

Type: _____



IP66



COAST



DMX/RDM



ANSI 3G



IK08



The Vista Plus Maxi White is an AC line powered, high brightness luminaire. Controllable with DMX512, the Vista Plus Maxi White is a new member of the Vista Plus family, offering 200W per head with 1-head, 2-head options. The daisy chain topology, and direct-wire nature of the fixture via the two integral cable whips allow for simple installation into existing installations and new structures, and is ideal for high-rise and tower illumination.

Features

- DMX / RDM control
- Easy installation and maintenance
- Assortment of optical and installation accessories

Dimensions

Unit: mm

Vista Plus Maxi 1x200W

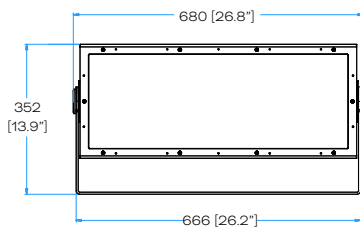

Vista Plus Maxi 2x200W

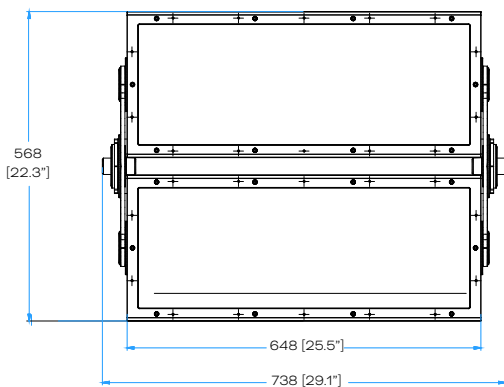

Technologies

- Auto-Addressing / Manual Addressing
- DMX / RDM control

Color Options

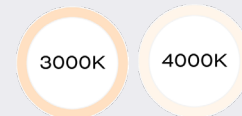

3000K / 4000K Std; 2700K, 3500K, 5700K, 6500K available DW on demand

Beam Angles

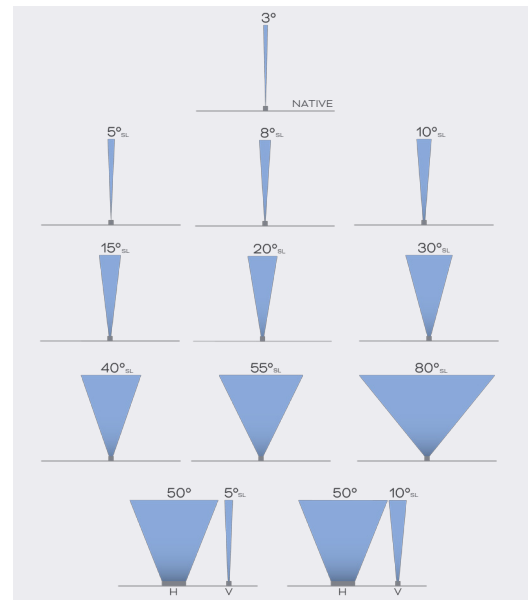

Finish



Traxon Signature Gray
RAL 7005

RAL 7015

RAL 9005

RAL 9003

Custom

Product Specifications

Model	1 x 200W	2 x 200W
Light Source	White LED x 48	White LED x 96
Pixel	1 pixel per head, each head can be controlled individually	
Color Range	3000K / 4000K Std; 2700K, 3500K, 5700K, 6500K available DW on demand (e.g. 2700K+5700K)	
LED Quantity	White LED 48 pcs (DW on demand, 24pcs WW, 24pcs CW)	White LED 96 pcs (DW on demand, 48pcs WW, 48pcs CW)
Luminous Flux (4000K)	22000 lm (3° SW)	44000 lm (3° SW)
Candela (4000K)	2904000 cd (3° SW)	5808000 cd (3° SW)
Efficacy (4000K)	110 lm/W (3° SW)	
CRI	90 CRI by request: 2700K-4000K (CRI90)	
Beam Angles	3° native ¹ ; 5°, 8°, 10°, 15°, 20°, 30°, 40°, 55°, 80°, 50° x 10°, 50° x 5° via accessory	
Cover Lens	Tempered Glass	
Housing	Die Cast Aluminum	
Housing Finish Options	Standard color: Traxon Signature Gray (RAL7005) Optional color: Gray (RAL7015), Black (RAL9005), White (RAL9003), Custom	
Adjustment Options	1x200W: ±90° vertical 2x200W: ±30° vertical per head, see page 5 for additional information	
Mounting	Surface Mount Optional mounting accessories are available	
Dimensions (W x D x H)	680mm x 352mm x 268mm (26.8" x 13.9" x 10.6")	738mm x 648mm x 174mm (29.1" x 25.5" x 6.9")
Weight	22.3 kg (49.17 lbs.)	45.5 kg (100.31 lbs.)
EPA	Front: 1.17 Side: 0.63	Front: 1.25 Side: 1.48
Regulatory Listing & Safety Approval	cETLus, CE, UKCA, FCC, RoHS, REACH, ASTM B117-16, ANSI 3G	
Operating Temperature	-30°C to +55°C / -22°F to +131°F	
Minimum Starting Temperature	-20°C / -4°F	
Storage Temperature	-40°C to +80°C / -40°F to +176°F	
Environment	Outdoor, IP66, IK08, Coastal Environment (ASTM B117-16)	
Humidity	85%, non-condensing	

Electrical Specifications

Operating Voltage ²	120-277V AC 50/60Hz	
Power Consumption (W)	200	400
Lumen Maintenance	L70 @25°C 81,000hrs	
Power Factor	> 0.9	

System Specifications

Power Supply	AC line
Control	DMX/RDM RDM personality: 16 bit 0-10V Dimming on demand (White only)
Addressing Options ³	Auto-addressing ON or Auto-addressing OFF (Default as Auto-addressing OFF, address through RDM)

1: 3° native with actual measurement of avg. 3.3°.
2: Auto-switching, Single phase (line, neutral and ground).
3: Auto-addressing Off (i.e. Manual addressing) is as default.

LED CHARACTERISTICS Because LEDs are semiconductor devices, their performances are subject to inherent variability commonly found in semiconductor industry. To improve consistency in performance across the same product, LED manufacturers "sort" LEDs into bins according to different preset parameters, such as forward driving voltage, illumination, etc. Whereas binning is a sorting function, it is not a correction process. Inherent variability in the manufacturing process results always in different binning distributions according to different production lots. Traxon uses automatically binned LEDs on its products, thereby minimizing output variations within the model range.

As with all electronic devices, LED output degrades over time – a term called lumen depreciation. This also explains why it is nearly impossible to expect photometric performances of two LED products with different service life spans to be the same. The rate of LED degrade is a complicated function of many factors such as operating efficiency, duration of continuous operation, and more significantly, environmental conditions (ambient temperature for example). If allowed working under optimal operating temperature range and with good ventilation, LED devices enjoy long service lives over conventional light sources. When using/installing LED devices, care should be taken to ensure that the devices will operate within the operating conditions specified in respective product literature.

Lumen measurement complies with LM-79-08 standard.
Lumen maintenance is calculated based on LM-80 compliant measurement.

Source Specifications

Length Option	1x200W	2x200W
Source	White LED 48 pcs (DW on demand, 24pcs WW, 24pcs CW)	White LED 96 pcs (DW on demand, 48pcs WW, 48pcs CW)
Optics	3°	

Candela Distribution

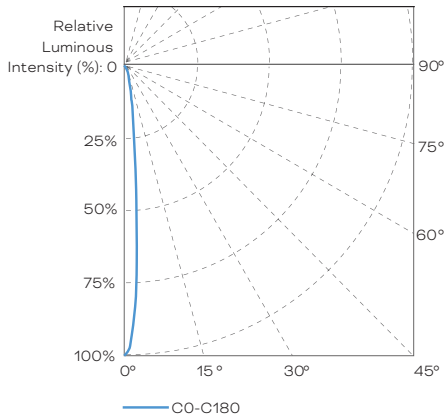

Light Output

	Color	Luminous Flux (lm)	Center Intensity (cd)	Efficacy (lm/W)
1x200W	3000K	19360.0	2555520	96.8
	4000k	22000.0	2904000	110.0
2x200W	3000K	38720.0	5110400	96.8
	4000k	44000.0	5808000	110.0

Illuminance at a Distance

	Center Beam LUX/klm	Beam Width	
20m	402	1.12m / 3.67'	65.62'
40m	101	2.23m / 7.32'	131.23'
60m	45	3.35m / 10.99'	196.85'
80m	25	4.47m / 14.67'	262.47'
100m	16	5.59m / 18.34'	328.08'
120m	11	6.70m / 21.98'	393.70'

● Horiz.Spread: 3.2°

For Foot-candle divide by 10.7

IES and LDT files are available for download from the Traxon website.

	Power input cable	Data in / out cable (combined)
Cable Length (open wire)	1830mm [72"]	1830mm [72"]
Cable Outer Diameter	7.8mm [0.31"]	8.1mm [0.32"]

Fixture - 1x200W

Unit: mm

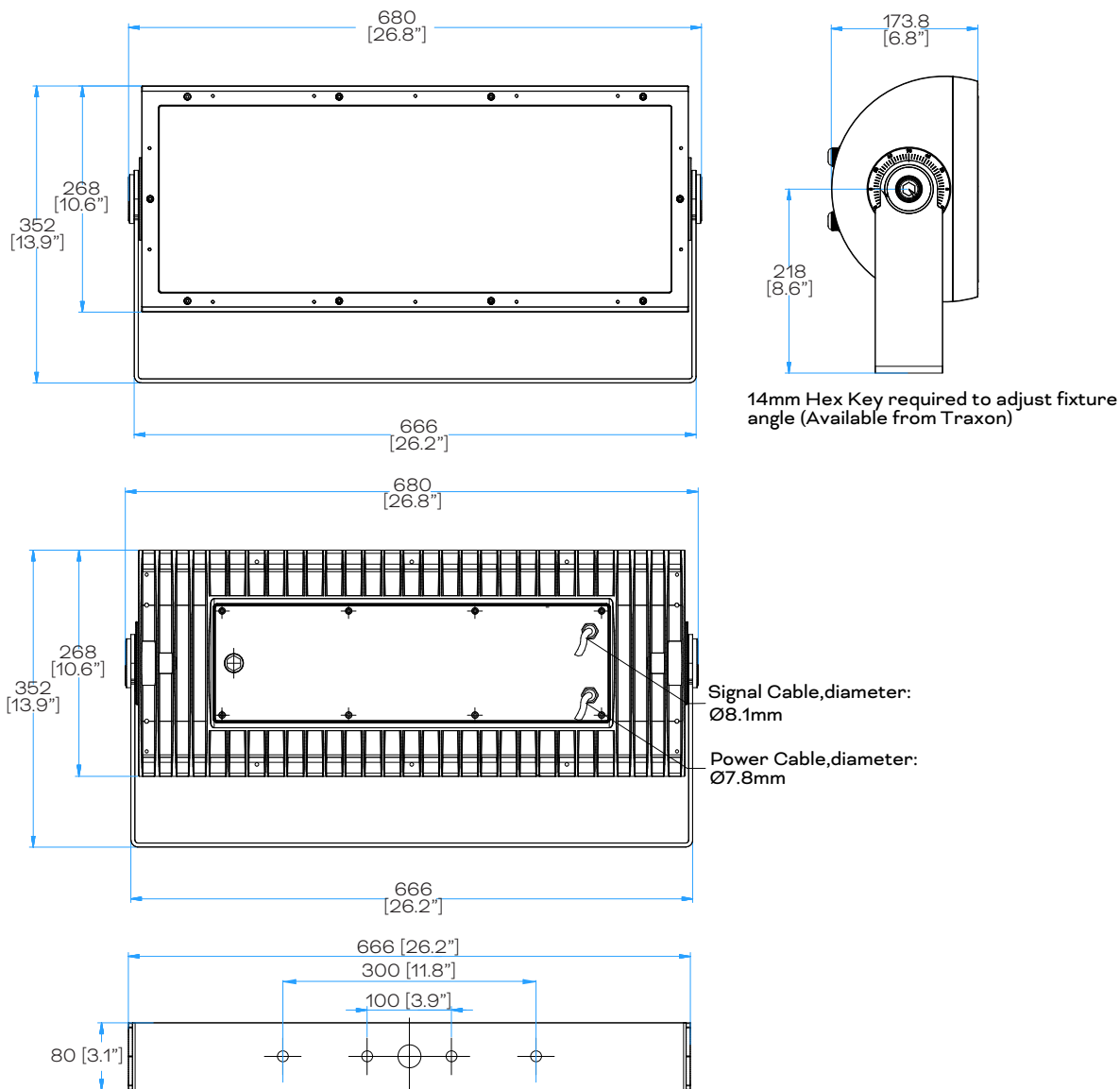

NOTE: Please see CAD files for additional dimensional data.

Fixture - 2x200W

Unit: mm

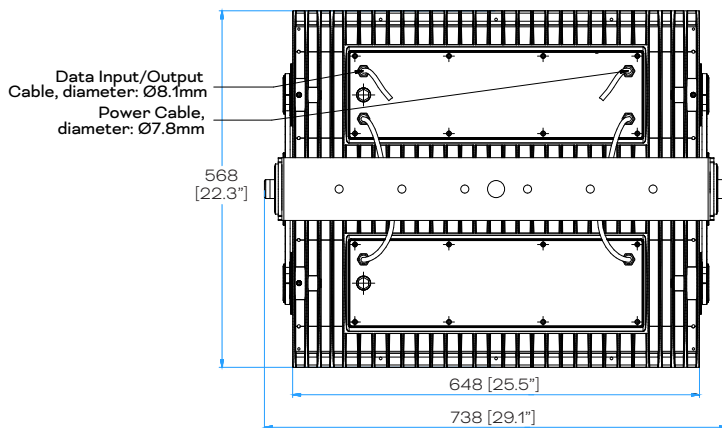
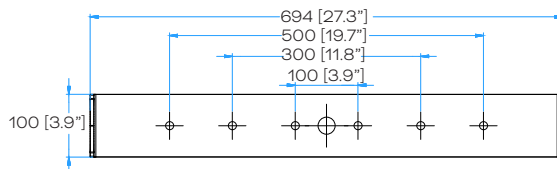
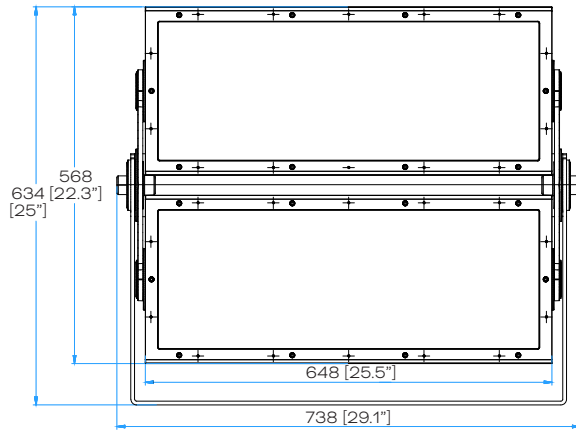
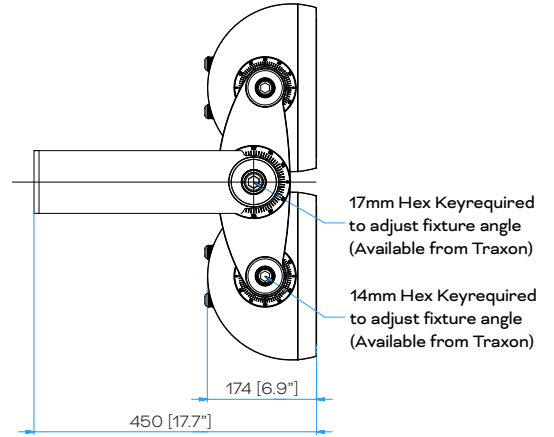
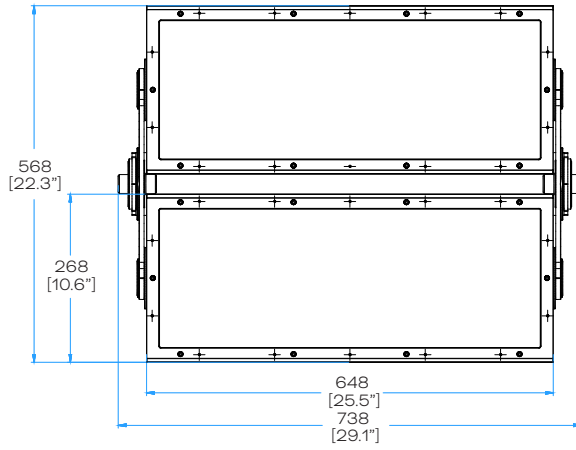

NOTE: Please see CAD files for additional dimensional data.

Mounting Accessories

Model No.	Description	Item Code
N/A	VISTA PLUS POLE-MOUNTING SUPPORT	AM380750055
N/A	VISTA PLUS POLE-MOUNTING SUPPORT BL	AM380900055
N/A	VISTA PLUS POLE-MOUNTING SUPPORT WT	AM381050055

Unit: mm

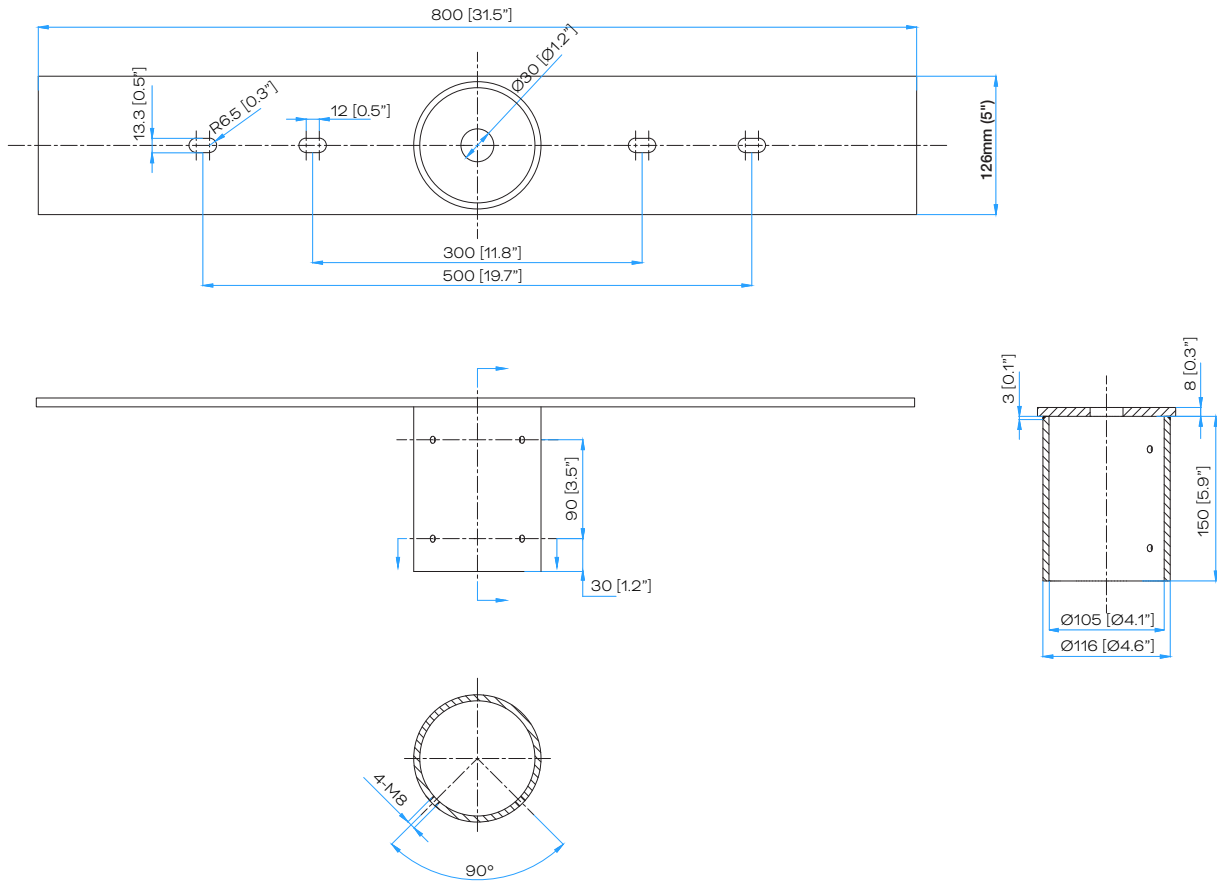

Optical Accessories

Full Glare Shield

Model No.	Description	Item Code
N/A	VISTA PLUS 200W FULL SHIELD	AM380720055
N/A	VISTA PLUS 200W FULL SHIELD BL	AM380880055
N/A	VISTA PLUS 200W FULL SHIELD WT	AM381030055

Unit: mm

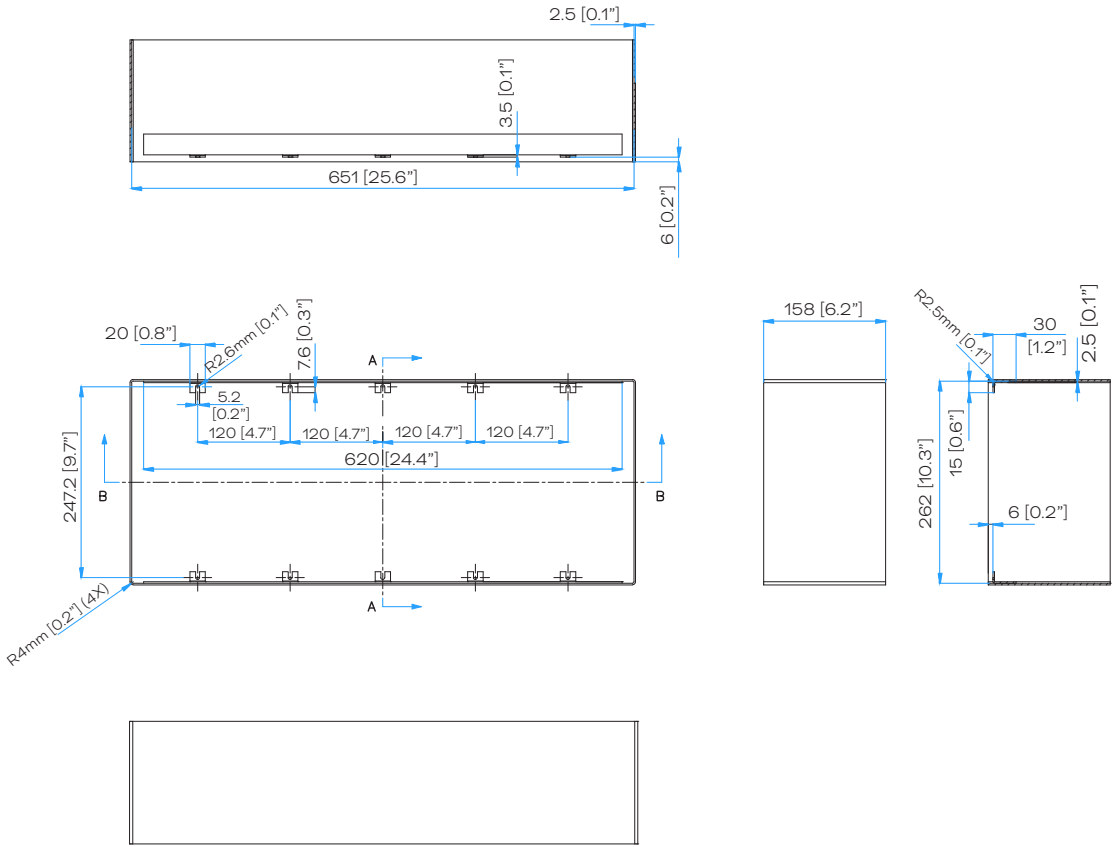

Optical Accessories

Half Glare Shield

Model No.	Description	Item Code
N/A	VISTA PLUS 200W HALF SHIELD	AM380690055
N/A	VISTA PLUS 200W HALF SHIELD BL	AM380870055
N/A	VISTA PLUS 200W HALF SHIELD WT	AM381020055

Unit: mm

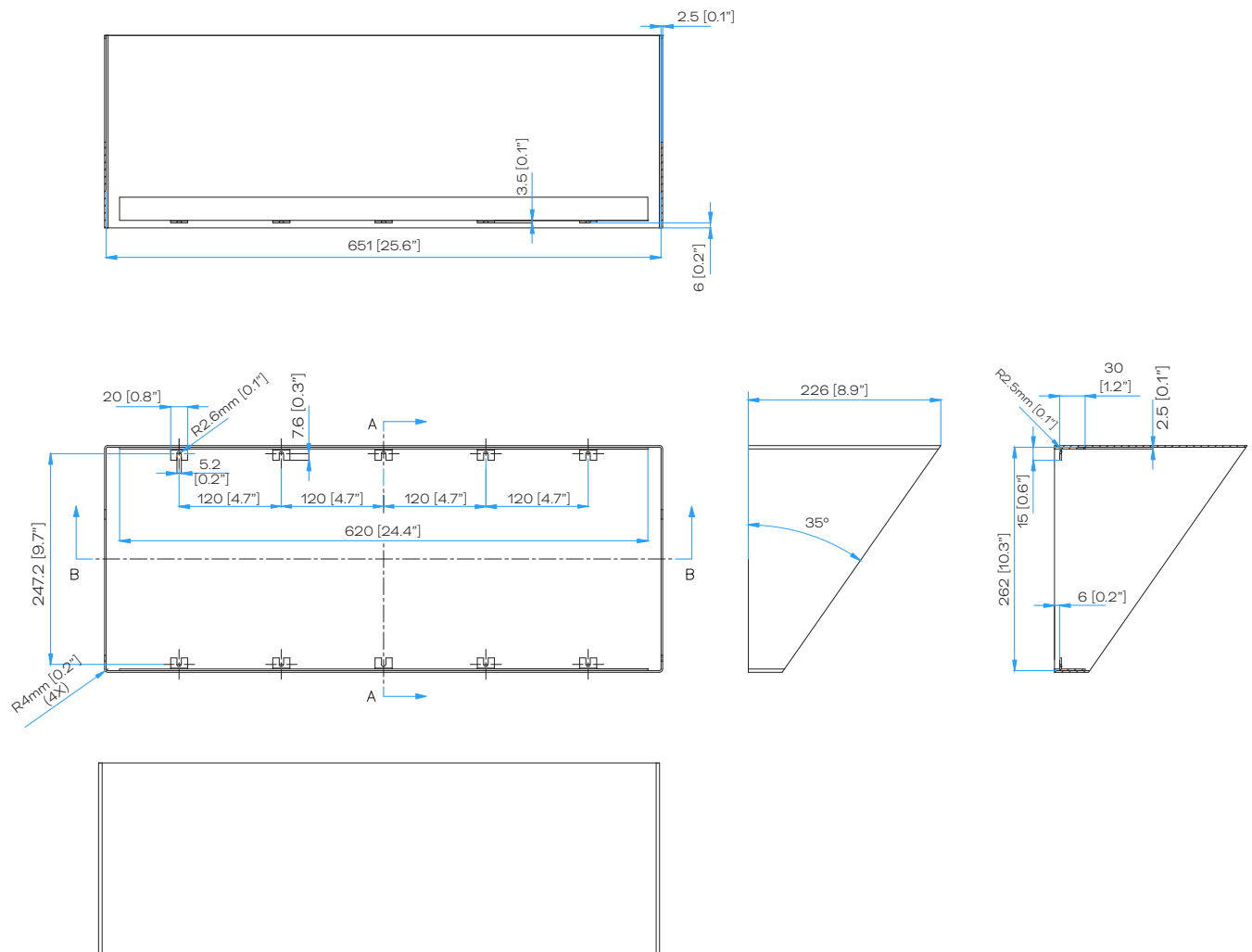

NOTE: Please see CAD files for additional dimensional data.

Optical Accessories

Rock Guard

Model No.	Description	Item Code
N/A	VISTA PLUS 200W ROCK GUARD	AM380730055
N/A	VISTA PLUS 200W ROCK GUARD BL	AM380890055
N/A	VISTA PLUS 200W ROCK GUARD WT	AM381040055

Unit: mm

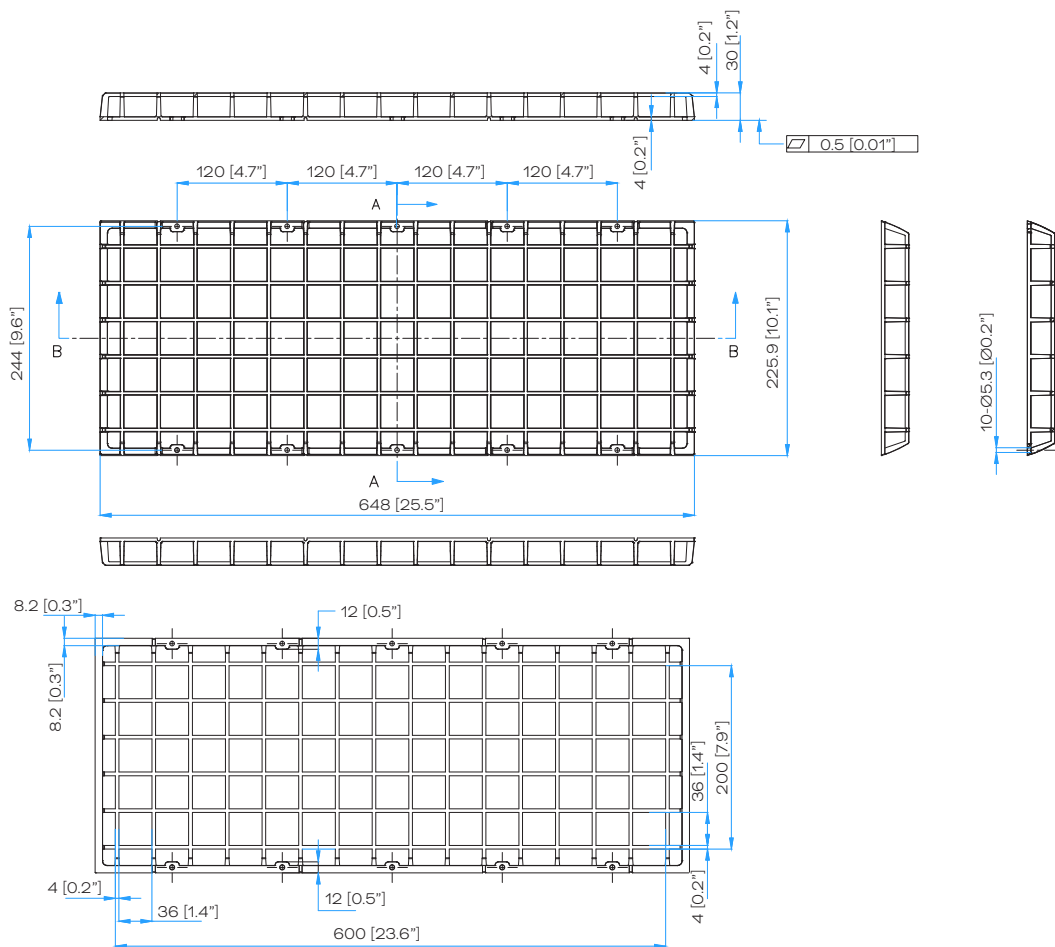

NOTE: Please see CAD files for additional dimensional data.

Optical Accessories

Spread Lens Module

Model No.	Description	Item Code
N/A	VISTA PLUS 200W SPREAD MODULE 5 / 5 BL/ 5 WT	AM380760055 / AM380860055 / AM381060055
N/A	VISTA PLUS 200W SPREAD MODULE 8 / 8 BL/ 8 WT	AM380770055 / AM380920055 / AM381070055
N/A	VISTA PLUS 200W SPREAD MODULE 10 / 10 BL/ 10 WT	AM380780055 / AM380930055 / AM381080055
N/A	VISTA PLUS 200W SPREAD MODULE 15 / 15 BL/ 15 WT	AM380790055 / AM380940055 / AM381090055
N/A	VISTA PLUS 200W SPREAD MODULE 20 / 20 BL/ 20 WT	AM380800055 / AM380950055 / AM381100055
N/A	VISTA PLUS 200W SPREAD MODULE 30 / 30 BL/ 30 WT	AM380810055 / AM380960055 / AM381110055
N/A	VISTA PLUS 200W SPREAD MODULE 40 / 40 BL/ 40 WT	AM380820055 / AM380970055 / AM381120055
N/A	VISTA PLUS 200W SPREAD MODULE 55 / 55 BL/ 55 WT	AM380830055 / AM380980055 / AM381130055
N/A	VISTA PLUS 200W SPREAD MODULE 80 / 80 BL/ 80 WT	AM380840055 / AM380990055 / AM381140055
N/A	VISTA PLUS 200W SPREAD MODULE 50X10 / 50X10 BL/ 50X10 WT	AM380850055 / AM381000055 / AM381150055
N/A	VISTA PLUS 200W SPREAD MODULE 50X5 / 50X5 BL/ 50X5 WT	AM380860055 / AM381010055 / AM381160055

Unit: mm

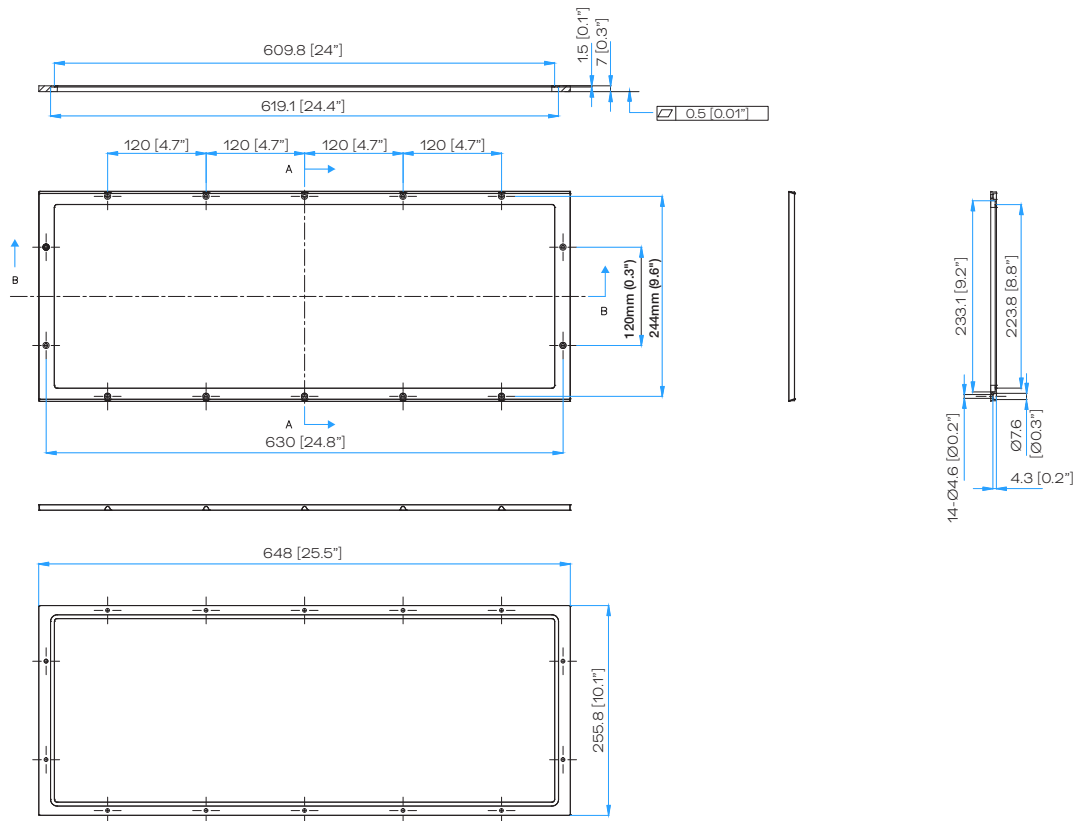

NOTE: Please see CAD files for additional dimensional data.

Wiring Diagram - 1x200W

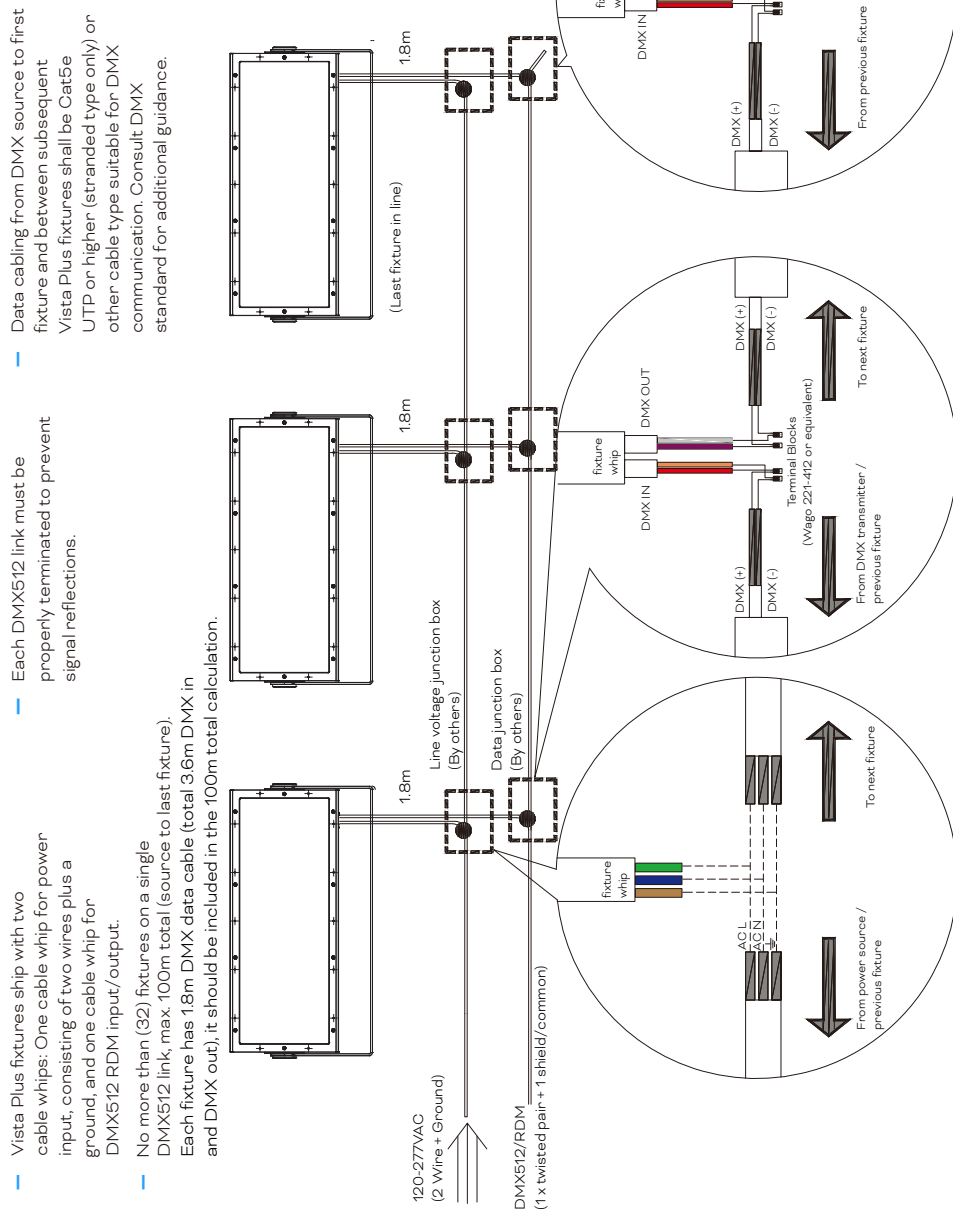

— Data cabling from DMX source to first fixture and between subsequent Vista Plus fixtures shall be Cat5e UTP or higher (stranded type only) or other cable type suitable for DMX communication. Consult DMX standard for additional guidance.

— Each DMX512 link must be properly terminated to prevent signal reflections.

— Vista Plus fixtures ship with two cable whips: One cable whip for power input, consisting of two wires plus a ground, and one cable whip for DMX512 RDM input/output.

— No more than (32) fixtures on a single DMX512 link, max. 100m total (source to last fixture). Each fixture has 18m DMX data cable (total 3.6m DMX in and DMX out), it should be included in the 100m total calculation.

General Notes

- All data cabling must adhere to ANSI E1:11-2008 (R2013) – Entertainment Technology – USITT DMX512-A, Asynchronous Serial Digital Data Transmission Standard for Controlling Lighting Equipment and Accessories.
- Fixture is RDM compatible.
- Fixtures allow a universal input of 120V AC to 277V AC.
- Data termination shall utilize cage clamp terminal blocks, or equivalent. Wire nuts are not permissible and will void warranty.
- The method of line voltage termination, both for data and power, is at the discretion of the installing contractor, and/or engineer. Splicing and/or joining of cables must adhere to all applicable electrical codes.
- Cables must be spliced/joined in a weatherproof enclosure/junction box, which is to be properly rated and provided by others.

Wiring Diagram - 2x200W

- Vista Plus fixtures ship with two cable whips: One cable whip for power input, consisting of two wires plus a ground, and one cable whip for DMX512 RDM input/output.
- No more than (32) fixtures on a single DMX512 link, max. 100m total (source to last fixture). Each fixture has 1.8m DMX data cable (total 3.6m DMX in and DMX out), it should be included in the 100m total calculation.
- Each DMX512 link must be properly terminated to prevent signal reflections.
- Data cabling from DMX source to first fixture and between subsequent Vista Plus fixtures shall be Cat5e UTP or higher (stranded type only) or other cable type suitable for DMX communication. Consult DMX standard for additional guidance.

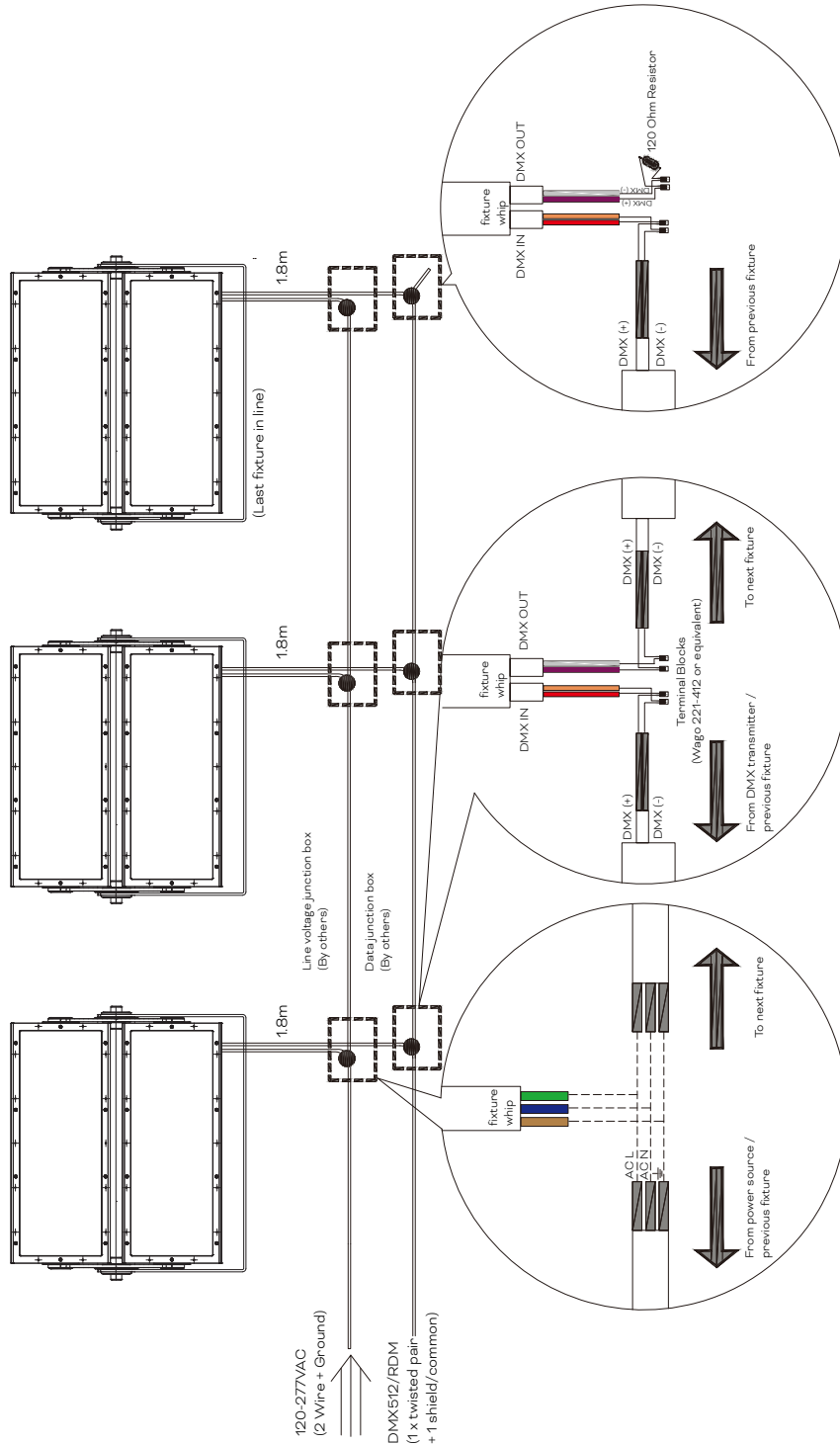

General Notes

- All data cabling must adhere to ANSI/E11-2008 (R2013) – Entertainment Technology – USITT DMX512-A, Asynchronous Serial Digital Data Transmission Standard for Controlling Lighting Equipment and Accessories.
- Fixtures are RDM compatible.
- Fixtures allow a universal input of 120V AC to 277V AC.
- Data termination shall utilize cage clamp terminal blocks, or equivalent. Wire nuts are not permissible and will void warranty.
- The method of line voltage termination, both for data and power, is at the discretion of the installing contractor, and/or engineer. Splicing and/or joining of cables must adhere to all applicable electrical codes.
- Cables must be spliced/joined in a weatherproof enclosure/junction box, which is to be properly rated and provided by others.

Model Number Builder

VI.	PL.	N	3	2	N	1	1	1	1	1	N	0	0
		Number of Head	Wattage per head	LED	CCT	Optics	Control	Pixel	Approbation	Mounting/ Add On	Color Finish	Cable/ Connector	
		4: 1-head	3 - 200W AC per head	2 - White	4 - 3000K	1 - 3°	1 - DMX/RDM	1 - 1 pixel per head	1 - CE & ETL	1 - 3G vibration	0 - TX Signature Gray	0 - Standard version	
		5: 2-head			5 - 4000K						1 - Gray		
					6 - 5700K						2 - Black		
					7 - 6500K						3 - White		
					8 - DW2757 (2700K + 5700K)								

EXAMPLE VISTA PLUS MAXI 2x200W AC WHITE 3000K 3° TX-GRAY CE
Model VI.PL.5324111100

VI.	PL.	5	3	2	4	1	1	1	1	1	1	0	0
-----	-----	---	---	---	---	---	---	---	---	---	---	---	---

Project Model Number

VI.	PL.		3	2		1	1	1	1	1		0	0
-----	-----	--	---	---	--	---	---	---	---	---	--	---	---

Fixture

Model No.	Description	Item Code
VI.PL.432341111100	VISTA PLUS MAXI 1x200W AC 3000K 3° TX-GRAY	DL26103655955
VI.PL.432351111100	VISTA PLUS MAXI 1x200W AC 4000K 3° TX-GRAY	DL26103656055
VI.PL.532341111100	VISTA PLUS MAXI 2x200W AC 3000K 3° TX-GRAY	DL26103656455
VI.PL.532351111100	VISTA PLUS MAXI 2x200W AC 4000K 3° TX-GRAY	DL26103656555

Mounting Accessories

Model No.	Description	Item Code
N/A	VISTA PLUS POLE-MOUNTING SUPPORT	AM380750055
N/A	VISTA PLUS POLE-MOUNTING SUPPORT BL	AM380900055
N/A	VISTA PLUS POLE-MOUNTING SUPPORT WT	AM381050055
N/A	PROPOINT TERMINATION KIT	AM243520054

Optical Accessories

Model No.	Description	Item Code
N/A	VISTA PLUS 200W HALF SHIELD	AM380690055
N/A	VISTA PLUS 200W FULL SHIELD	AM380720055
N/A	VISTA PLUS 200W ROCK GUARD	AM380730055
N/A	VISTA PLUS 200W SPREAD MODULE - 5	AM380760055
N/A	VISTA PLUS 200W SPREAD MODULE - 8	AM380770055
N/A	VISTA PLUS 200W SPREAD MODULE - 10	AM380780055
N/A	VISTA PLUS 200W SPREAD MODULE - 15	AM380790055
N/A	VISTA PLUS 200W SPREAD MODULE - 20	AM380800055
N/A	VISTA PLUS 200W SPREAD MODULE - 30	AM380810055
N/A	VISTA PLUS 200W SPREAD MODULE - 40	AM380820055
N/A	VISTA PLUS 200W SPREAD MODULE - 55	AM380830055
N/A	VISTA PLUS 200W SPREAD MODULE - 80	AM380840055
N/A	VISTA PLUS 200W SPREAD MODULE - 50x10	AM380850055
N/A	VISTA PLUS 200W SPREAD MODULE - 50x5	AM380860055

Optical Accessories

Model No.	Description	Item Code
N/A	VISTA PLUS 200W HALF SHIELD BL	AM380870055
N/A	VISTA PLUS 200W FULL SHIELD BL	AM380880055
N/A	VISTA PLUS 200W ROCK GUARD BL	AM380890055
N/A	VISTA PLUS 200W SPREAD MODULE BL - 5	AM380910055
N/A	VISTA PLUS 200W SPREAD MODULE BL - 8	AM380920055
N/A	VISTA PLUS 200W SPREAD MODULE BL - 10	AM380930055
N/A	VISTA PLUS 200W SPREAD MODULE BL - 15	AM380940055
N/A	VISTA PLUS 200W SPREAD MODULE BL - 20	AM380950055
N/A	VISTA PLUS 200W SPREAD MODULE BL - 30	AM380960055
N/A	VISTA PLUS 200W SPREAD MODULE BL - 40	AM380970055
N/A	VISTA PLUS 200W SPREAD MODULE BL - 55	AM380980055
N/A	VISTA PLUS 200W SPREAD MODULE BL - 80	AM380990055
N/A	VISTA PLUS 200W SPREAD MODULE BL - 50x10	AM381000055
N/A	VISTA PLUS 200W SPREAD MODULE BL - 50x5	AM381010055
N/A	VISTA PLUS 200W HALF SHIELD WT	AM381020055
N/A	VISTA PLUS 200W FULL SHIELD WT	AM381030055
N/A	VISTA PLUS 200W ROCK GUARD WT	AM381040055
N/A	VISTA PLUS 200W SPREAD MODULE WT - 5	AM381060055
N/A	VISTA PLUS 200W SPREAD MODULE WT - 8	AM381070055
N/A	VISTA PLUS 200W SPREAD MODULE WT - 10	AM381080055
N/A	VISTA PLUS 200W SPREAD MODULE WT - 15	AM381090055
N/A	VISTA PLUS 200W SPREAD MODULE WT - 20	AM381100055
N/A	VISTA PLUS 200W SPREAD MODULE WT - 30	AM381110055
N/A	VISTA PLUS 200W SPREAD MODULE WT - 40	AM381120055
N/A	VISTA PLUS 200W SPREAD MODULE WT - 55	AM381130055
N/A	VISTA PLUS 200W SPREAD MODULE WT - 80	AM381140055
N/A	VISTA PLUS 200W SPREAD MODULE WT - 50x10	AM381150055
N/A	VISTA PLUS 200W SPREAD MODULE WT - 50x5	AM381160055

Note: Vista Plus 200W accessory is suitable for Vista Plus Maxi / Vista Plus HO Maxi.

