



TRAXON **Plus**<sup>+</sup>

# Vista **Plus**<sup>+</sup> Midi / HO Midi

## INSTALLATION GUIDE

V1.0

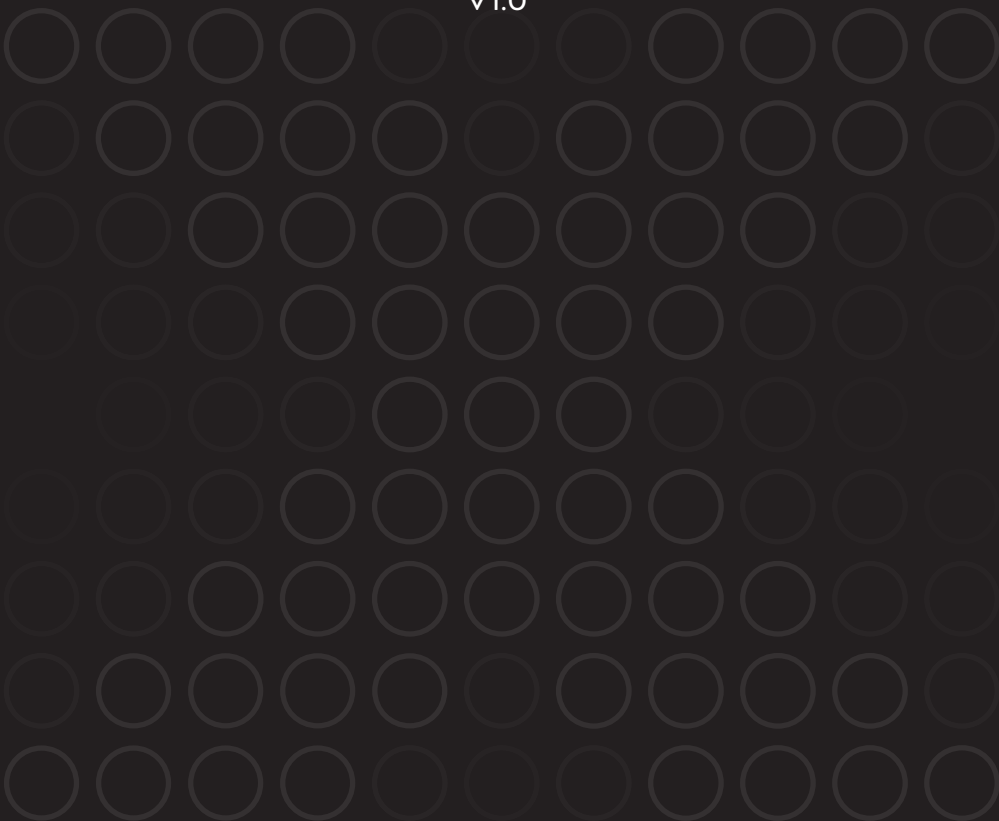

Vista Plus Midi

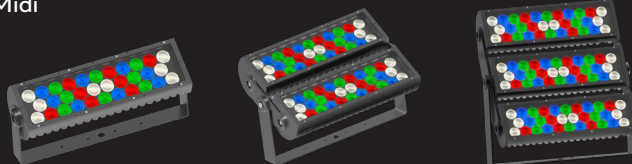

Vista Plus HO Midi

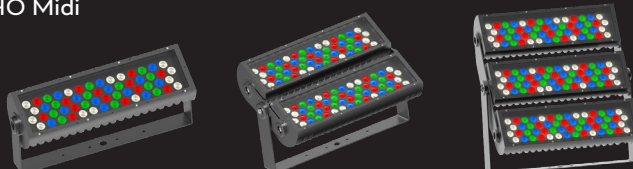

# Content

1.	Safety And Operation	3
2.	Introduction	4
3.	Installation	11
4.	System Configuration	21
5.	Care and Maintenance	28
6.	Technical Specification	28
7.	Troubleshooting	29
8.	Warranty Statement	29
9.	Appendix	30

For your own safety and that of the product, please read this installation guide carefully before beginning setup and installation.

# 1. Safety And Operation



Please read through Safety and Operation before start of the installation.

1. CAUTION - Unplug the power supply from the mains power before connecting any cables as this can damage the products.
2. CAUTION - Avoid looking directly into the LED light source at close range for your own safety.
3. Persons installing this product should make sure:
  - a. The installation complies with all applicable codes, state and local laws, ordinances, standards and safety regulations.
  - b. The installation environment is carefully studied and suitable surge protection measure(s) is taken.
  - c. He or she is qualified for the handling of electrical equipment.
4. Do not attempt to install or use the product until installation instructions and safety labels are fully understood. This product is designed for indoor and outdoor use.
5. Ensure product operates within the specified temperature range.
6. Do not attempt to open the product. Not user serviceable.
7. Do not use the product if any part of it, or the power cables are damaged.
8. Only use product for specified voltage, do not exceed.
9. Always maintain connection to ensure waterproofing.
10. If the product has been subjected to drastic temperature variances, for example, following transportation, do not connect the fixture until it has reached room temperature, as moisture condensation may cause electric shock and product damages.
11. When installing the products and system power supplies, please ensure they will not be exposed to moisture and extreme heat (and direct sunlight for outdoor products). Besides, keep a clean operating environment for the fixtures and system power supplies.
12. Please study this Installation Guide thoroughly and check the latest Technical Specification Sheets available from the Traxon website [www.traxon-ecue.com](http://www.traxon-ecue.com) before setup.
13. Any non-compliance of the Installation Guide will void the Traxon warranty.

## 2. Introduction

### 2.1 General

The Vista Plus Midi / HO Midi is an AC line powered, high brightness luminaire. Controllable with DMX512, the Vista Plus Midi / HO Midi is a new member of the Vista Plus family, offering 100W / 200W per head with 1-head, 2-head and 3-head options. The daisy chain topology, and direct-wire nature of the fixture allow for simple installation into existing installations and new structures, and is ideal for high-rise and tower illumination.

This product is intended for use in high-quality colored light applications.

#### Features:

- DMX / RDM control.
- Easy installation and maintenance.
- Dynamic Boost for RGBW / DW models.
- Assortment of optical and installation accessories.

### 2.2 Fixture Dimensions

FIG.1: Vista Plus Midi 1x100W / Vista Plus HO Midi 1x200W

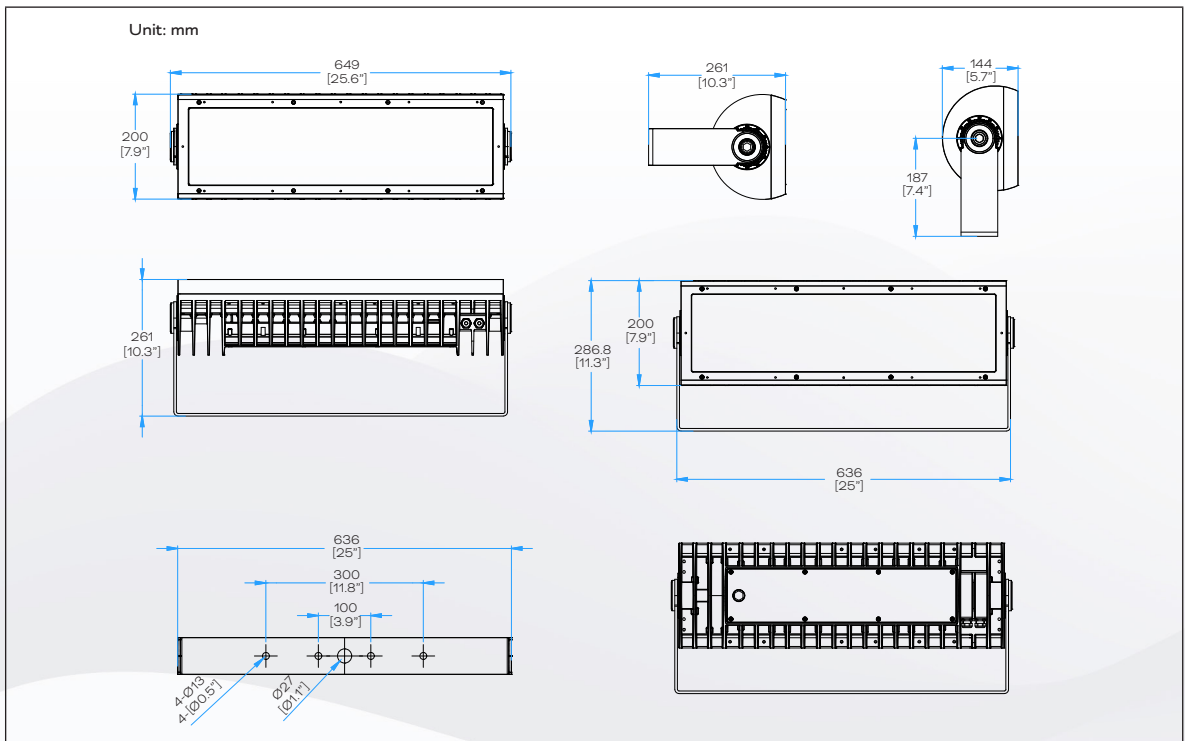

FIG.2: Vista Plus Midi 2x100W / Vista Plus HO Midi 2x200W

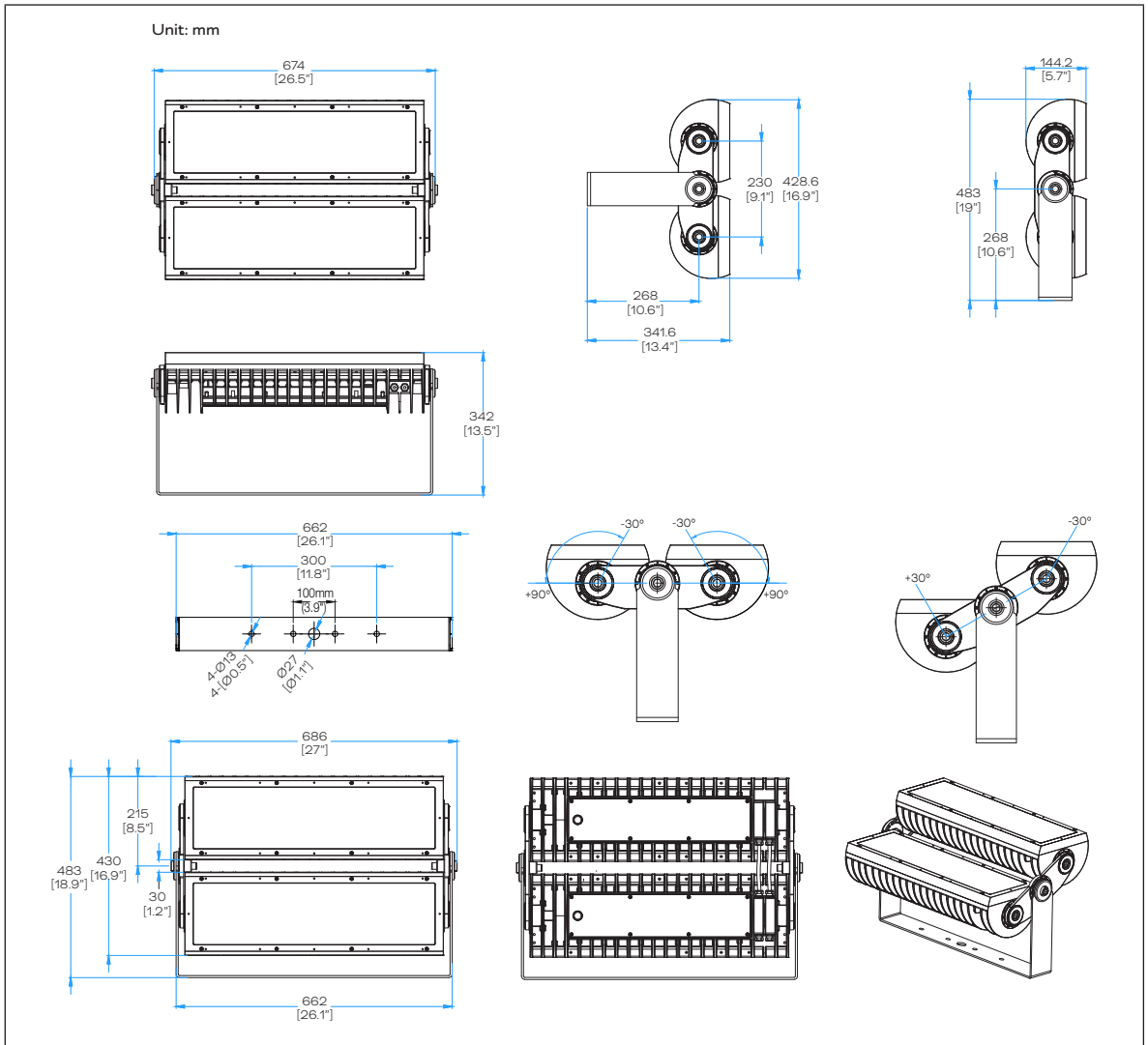
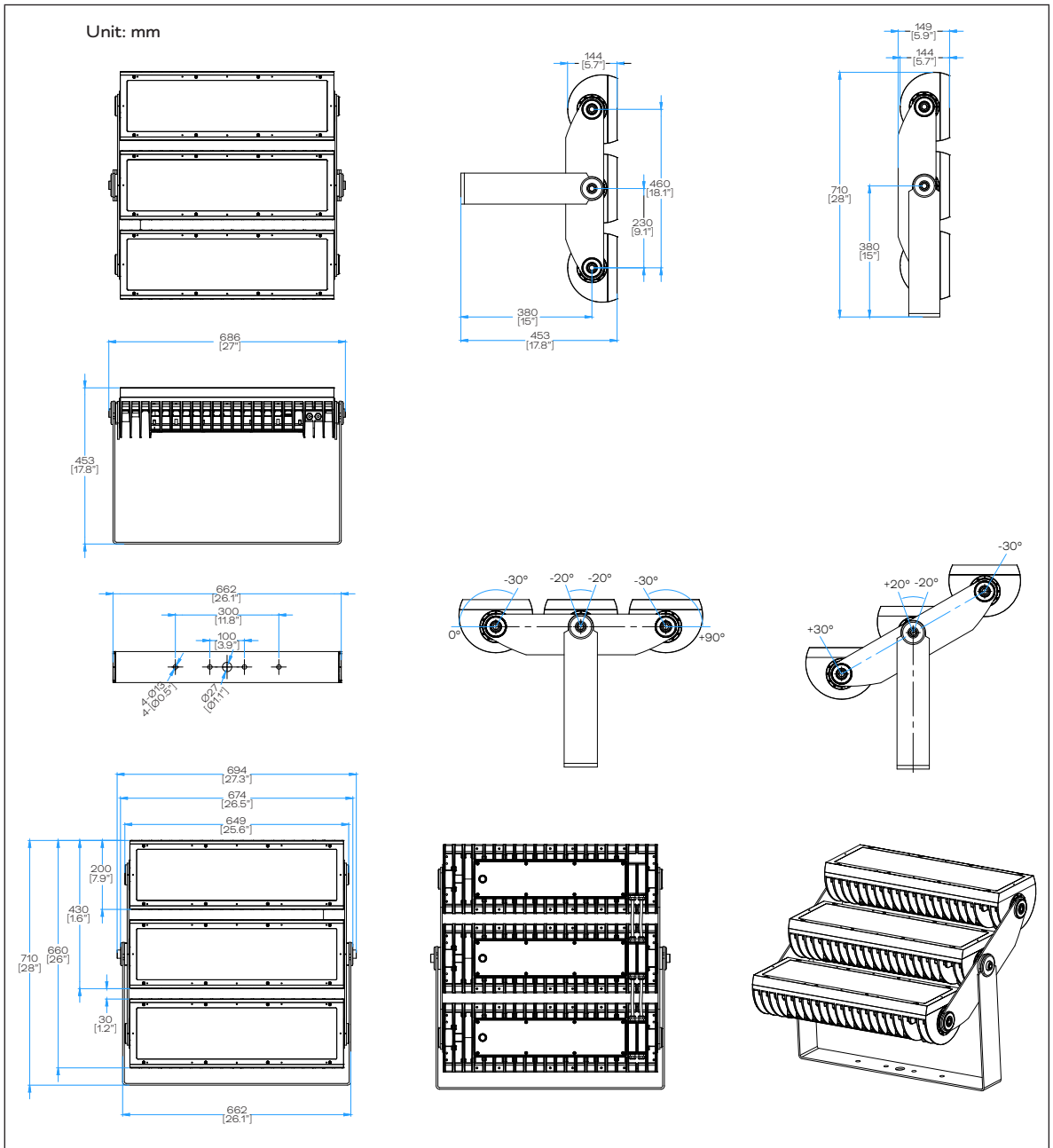

FIG.3: Vista Plus Midi 3x100W / Vista Plus HO Midi 3x200W



## 2.3 Optical Accessories Dimensions

FIG.4: Full Glare Shield

Model No.	Description	Item Code
N/A	VISTA PLUS 100W FULL SHIELD	AM410310055
N/A	VISTA PLUS 100W FULL SHIELD BL	AM410450055
N/A	VISTA PLUS 100W FULL SHIELD WT	AM410590055

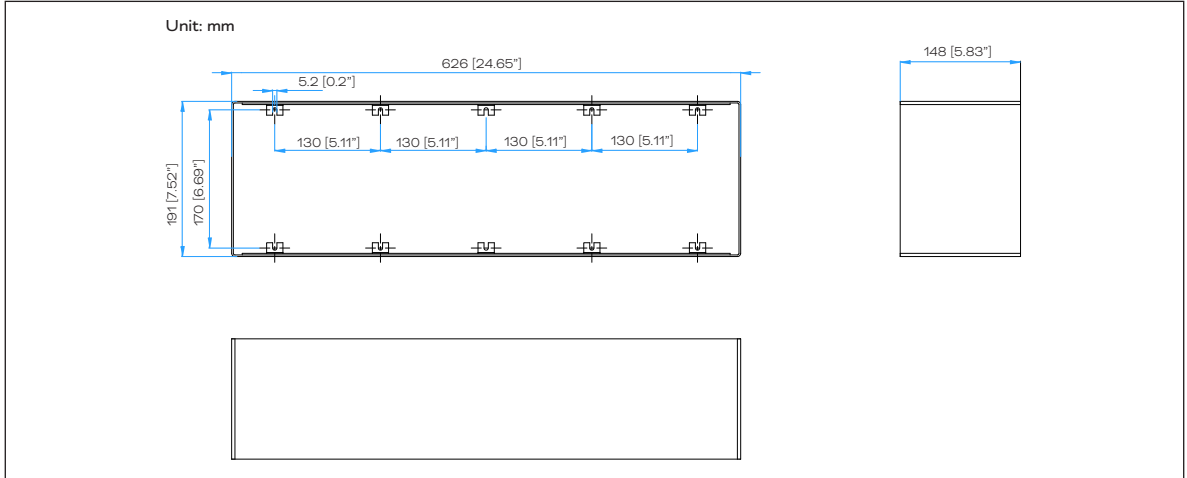

FIG.5: Half Glare Shield

Model No.	Description	Item Code
N/A	VISTA PLUS 100W HALF SHIELD	AM410300055
N/A	VISTA PLUS 100W HALF SHIELD BL	AM410440055
N/A	VISTA PLUS 100W HALF SHIELD WT	AM410580055

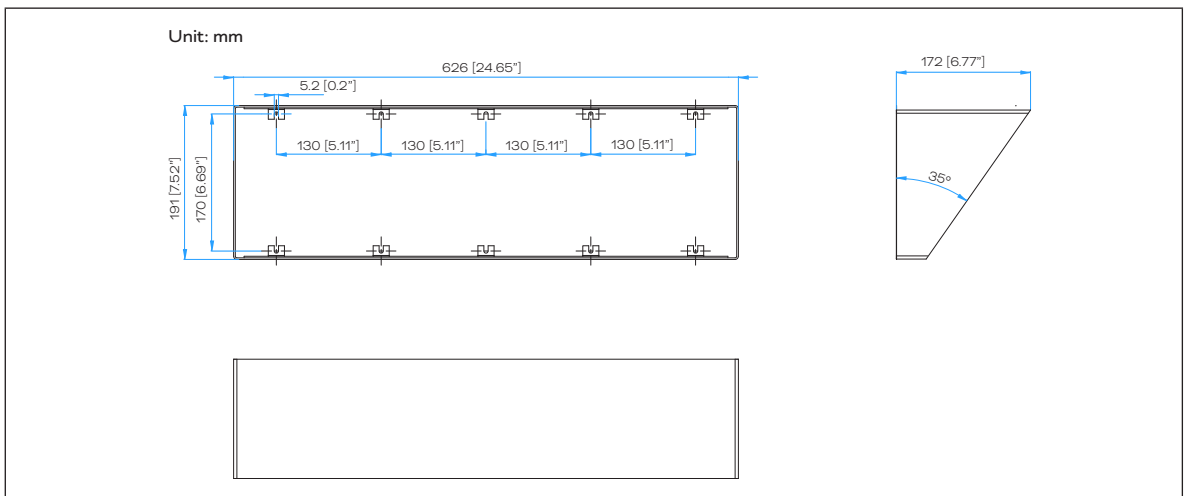

FIG.6: Rock Guard

Model No.	Description	Item Code
N/A	VISTA PLUS 100W ROCK GUARD	AM410320055
N/A	VISTA PLUS 100W ROCK GUARD BL	AM410460055
N/A	VISTA PLUS 100W ROCK GUARD WT	AM410600055

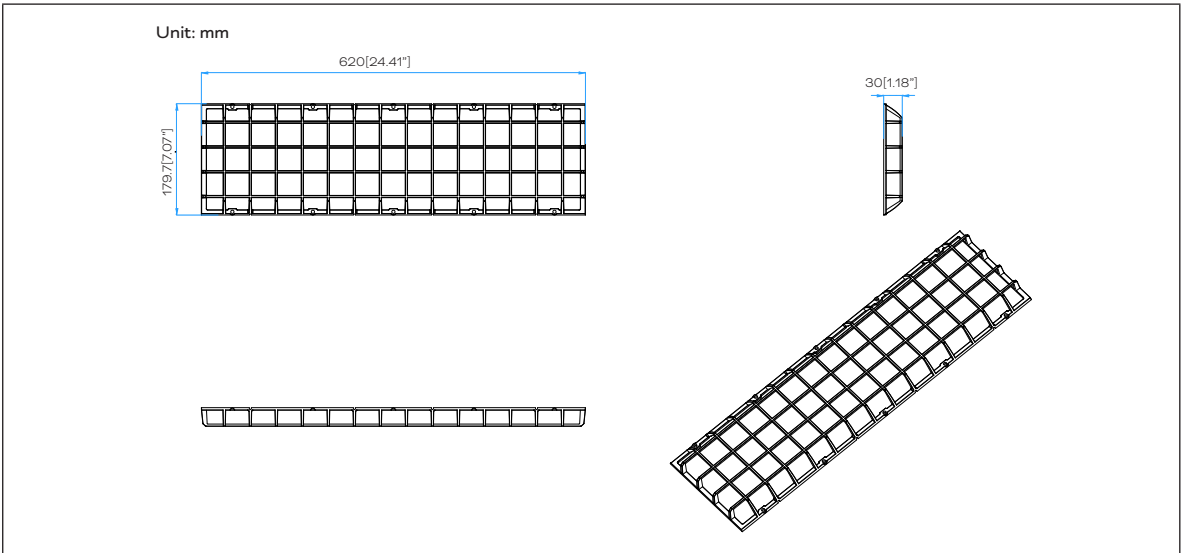
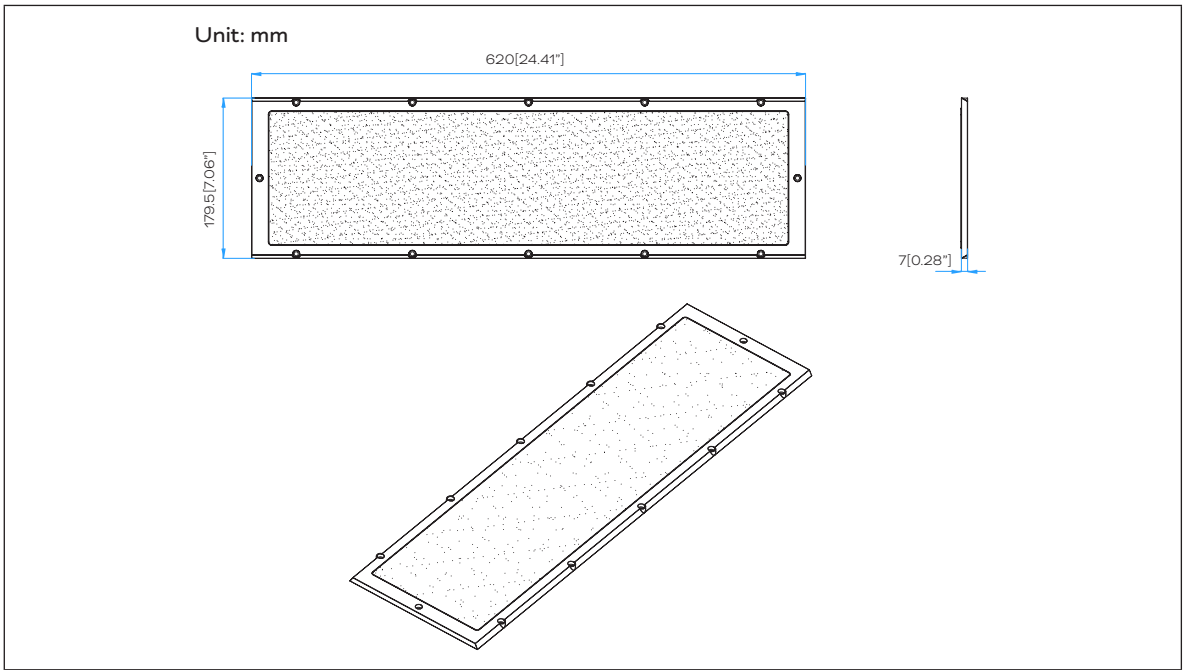

FIG.7: Spread Lens Module

Model No.	Description	Item Code
N/A	VISTA PLUS 100W SPREAD MODULE 5 / 5 BL/ 5 WT	AM410330055 / AM410470055 / AM410610055
N/A	VISTA PLUS 100W SPREAD MODULE 8 / 8 BL/ 8 WT	AM410340055 / AM410480055 / AM410620055
N/A	VISTA PLUS 100W SPREAD MODULE 10 / 10 BL/ 10 WT	AM410350055 / AM410490055 / AM410630055
N/A	VISTA PLUS 100W SPREAD MODULE 15 / 15 BL/ 15 WT	AM410360055 / AM410500055 / AM410640055
N/A	VISTA PLUS 100W SPREAD MODULE 20 / 20 BL/ 20 WT	AM410370055 / AM410510055 / AM410650055
N/A	VISTA PLUS 100W SPREAD MODULE 30 / 30 BL/ 30 WT	AM410380055 / AM410520055 / AM410660055
N/A	VISTA PLUS 100W SPREAD MODULE 40 / 40 BL/ 40 WT	AM410390055 / AM410530055 / AM410670055
N/A	VISTA PLUS 100W SPREAD MODULE 55 / 55 BL/ 55 WT	AM410400055 / AM410540055 / AM410680055
N/A	VISTA PLUS 100W SPREAD MODULE 80 / 80 BL/ 80 WT	AM410410055 / AM410550055 / AM410690055
N/A	VISTA PLUS 100W SPREAD MODULE 50X10 / 50X10 BL/ 50X10 WT	AM410420055 / AM410560055 / AM410700055
N/A	VISTA PLUS 100W SPREAD MODULE 50X5/ 50X5 BL/ 50X5 WT	AM410430055 / AM410570055 / AM410710055



## 2.4 Mounting Accessories Dimensions

FIG.8: Pole-Mounting Support

Model No.	Description	Item Code
N/A	VISTA PLUS POLE-MOUNTING SUPPORT	AM380750055
N/A	VISTA PLUS POLE-MOUNTING SUPPORT BL	AM380900055
N/A	VISTA PLUS POLE-MOUNTING SUPPORT WT	AM381050055

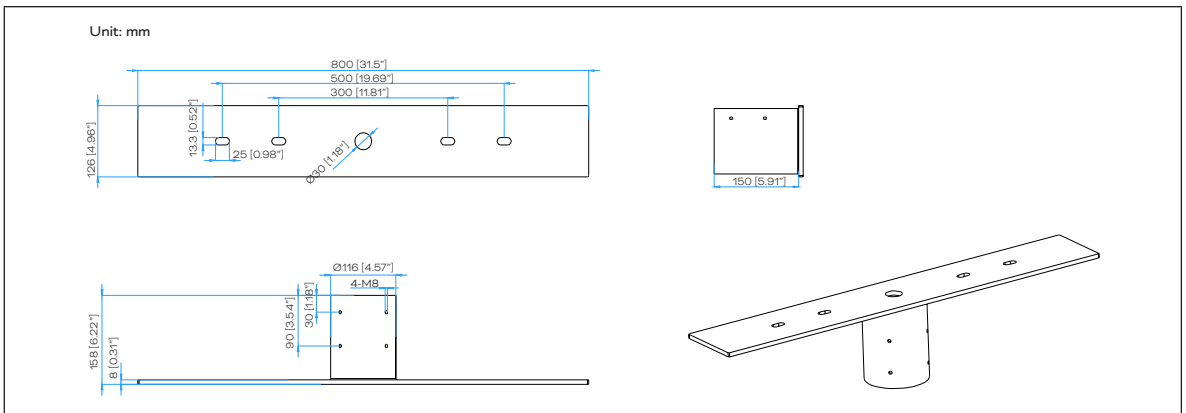

### **NOTE**

Vista Plus 100W accessory is suitable for Vista Plus Midi / Vista Plus HO Midi.

## 2.5 Additional Accessories

### Termination Kit

A ProPoint termination kit (part number AM243520054) may be purchased separately. This kit contains the following components:

- Splicing wire connectors: For use in connecting data cable conductors.
- 120 Ohm resistor for use in terminating the DMX512 data line at the last luminaire.

FIG.10: ProPoint Termination Kit



## 2.6 Packing Contents

FIG.11: Packing Contents

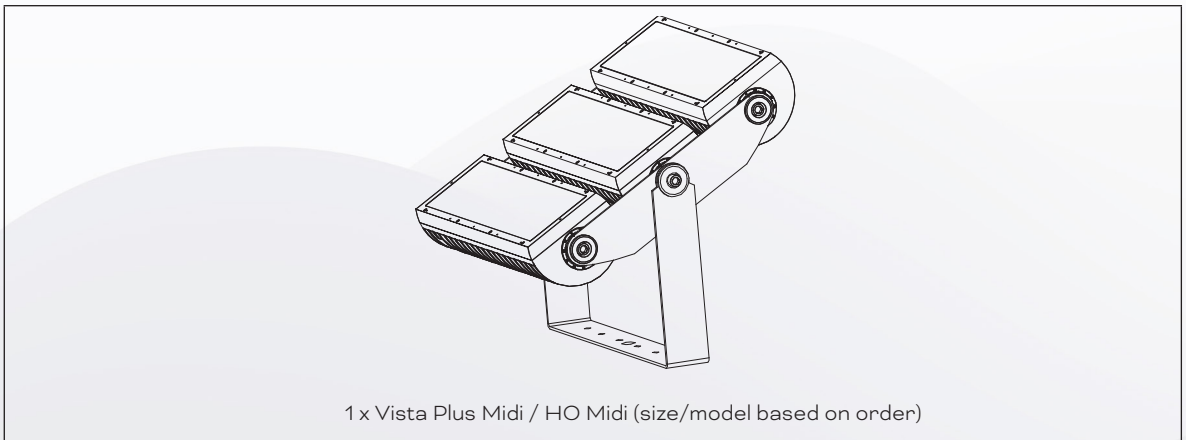

# 3. Installation

## 3.1 Points To Consider

Each Vista Plus luminaire is shipped with a mounting bracket suitable for Surface/Pole mount applications. Each Vista Plus luminaire is assembled with the yoke mount bracket suitable for surface/pole mount applications.

- Weather conditions and ambient temperature of installation site.
- Installation distances and appropriate cable lengths. Please consult your local Traxon office or authorized agent for necessary aid.
- The number of the fixtures and appropriate power sources.
- Mounting distances should be considered.
- Proper surge protection.

## 3.2 Pre-Installation Checks

### 3.2.1 Installation Checklist

1. Prepare cables and all necessary accessories.
2. Perform functional check of the Vista Plus Midi / HO Midi. Take care not to damage cables/connectors during pre-installation checks.
3. Mount the fixture on-site. If the installation is to be left uncompleted overnight, place all non-connected fixture, connection cables, Controller and LED Engines in an indoor environment.
4. Ensure all pre-installation checks laid out above have been followed.



- Ensure all the connection cables, Vista Plus Midi / HO Midi and power sources are initially stored in a dry area to guarantee the complete sealing of the system from water before installation.
- All fixtures and components are waterproof only when all connections are made. Failure to do this may result in non-warrantable water ingress.

## 3.3 On-Site Installation



- DO NOT attempt installation in wet or severe weather conditions.
- DO NOT leave and expose any Vista Plus Midi / HO Midi or power sources unconnected under wet/raining or snowing environment.
- IP failure induced by stressed/damaged cables during or after installation will not be under warranty by Traxon Technologies.
- ALWAYS keep the cables protected from sharp objects and ensure no damage is generated on the cable.
- Failure to keep Vista Plus Midi / HO Midi within the operating temperature range of -30°C to +55°C / -22°F to +131°F and storage temperature range of -40°C to +80°C / -40°F to +176°F will void the product's warranty.



This installation guide is applicable only to upright installation of the Vista Plus unit. For other installation orientation of the mounting bracket (e.g. side mounting, upside-down mounting, etc), please contact your local sales office for technical support and guidance.

### 3.3.1 Vista Plus Midi / HO Midi Surface Mount Installation

#### Required Tools

Vista Plus Midi 1x100W Model / Vista Plus HO Midi 1x200W Model	14mm and 17mm Hex Key
Vista Plus Midi 2x100W Model / Vista Plus HO Midi 2x200W Model	14mm and 17mm Hex Key
Vista Plus Midi 3x100W Model / Vista Plus HO Midi 3x200W Model	14mm and 17mm Hex Key

FIG.12: Surface Mount Installation

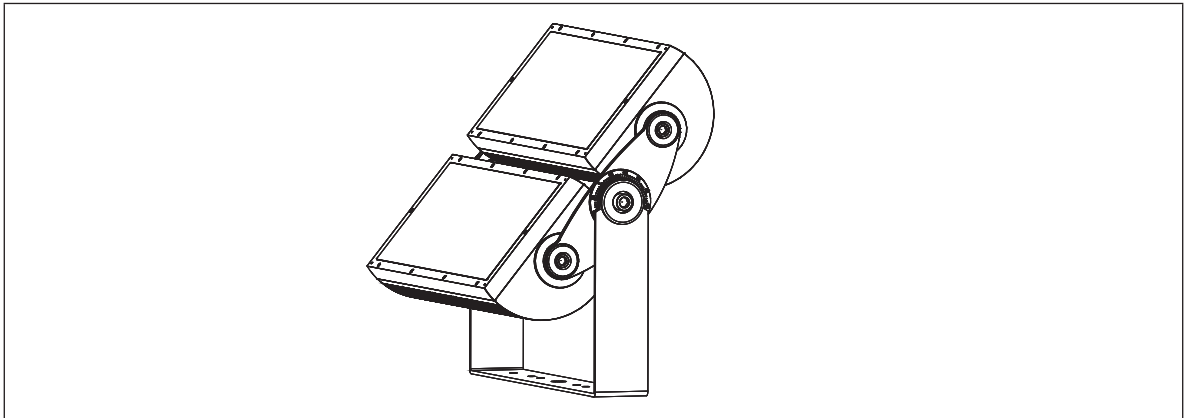

#### Preparation

- Remove the Vista Plus Midi / HO Midi luminaire from the packaging and place the unit on a level surface.



It is the installer's responsibility to ensure that the mounting surface can handle the static weight of the fixture as well as dynamic loading from environmental factors such as wind and snow/ice buildup. The use of Grade 5 or higher hardware is recommended.

- Make sure that the bolts on the mounting surface align with the holes on the surface mount bracket
- Install the luminaire to the mounting surface and secure using appropriate hardware (by others).



The Traxon Luminaire should be installed with the power and data cables exiting the housing directly down when the luminaire is mounted on a vertical surface. For applications that require horizontal orientation of the power and data cables, the installer shall apply RTV silicone to the cable gland entry points. The luminaire shall not be installed with the power and data cabling oriented up.

## Surface Mount Installation Steps

- After placing the stainless steel mounting bracket on the mounting surface, mark the positions of 4 mounting holes and drill 4 x M12 expanding anchors into the holes with the electric drill.

FIG.13: Surface Mount Step 1

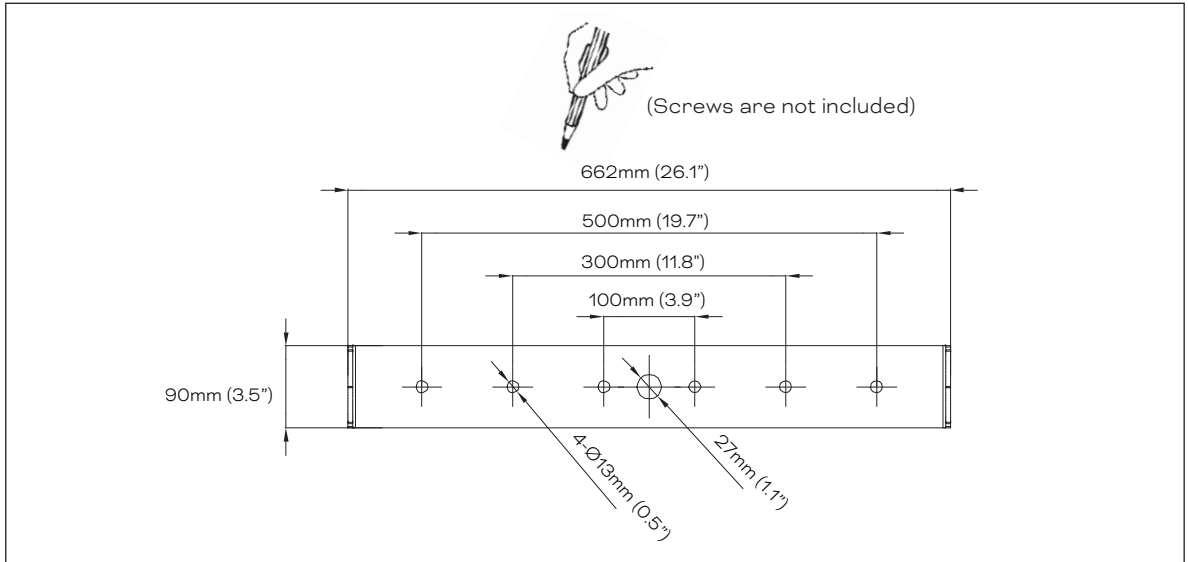

## Bracket Installation

- Mark the positions of mounting holes and drill M12 expanding anchors into the holes with the electric drill. Fix the M12\*50 hex bolt / Ø12 flat washer / Ø12 Spring washer as the following picture shows to install the bracket.

**NOTICE** It is the responsibility of the installer to ensure that the mechanical fixings are appropriate for the task and if necessary, approved by a structural engineer as the installation scenario is unique for each luminaire

FIG.14: Bracket Mounting

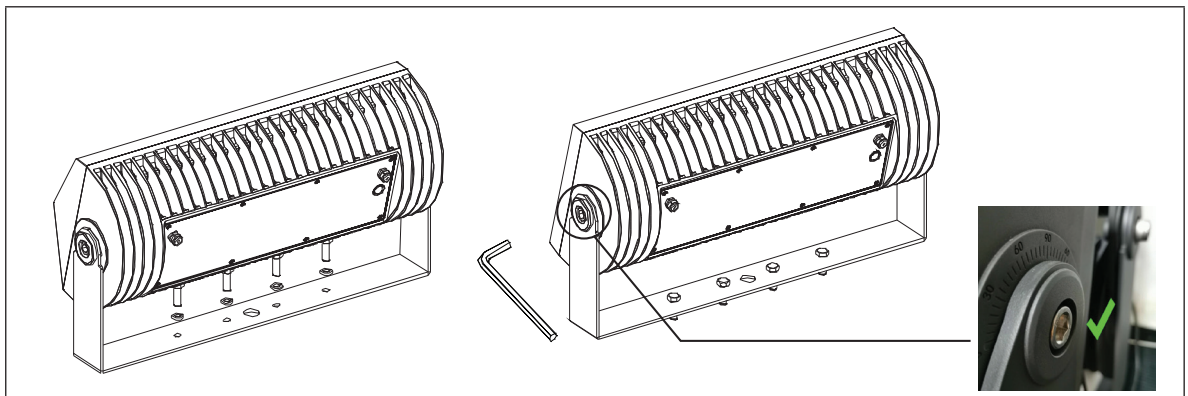

- After aligning 4 Ø13mm holes and expansion screws on the floor of the stainless steel mounting bracket, lock the mounting bracket.

FIG.15: Surface Mount Step 2

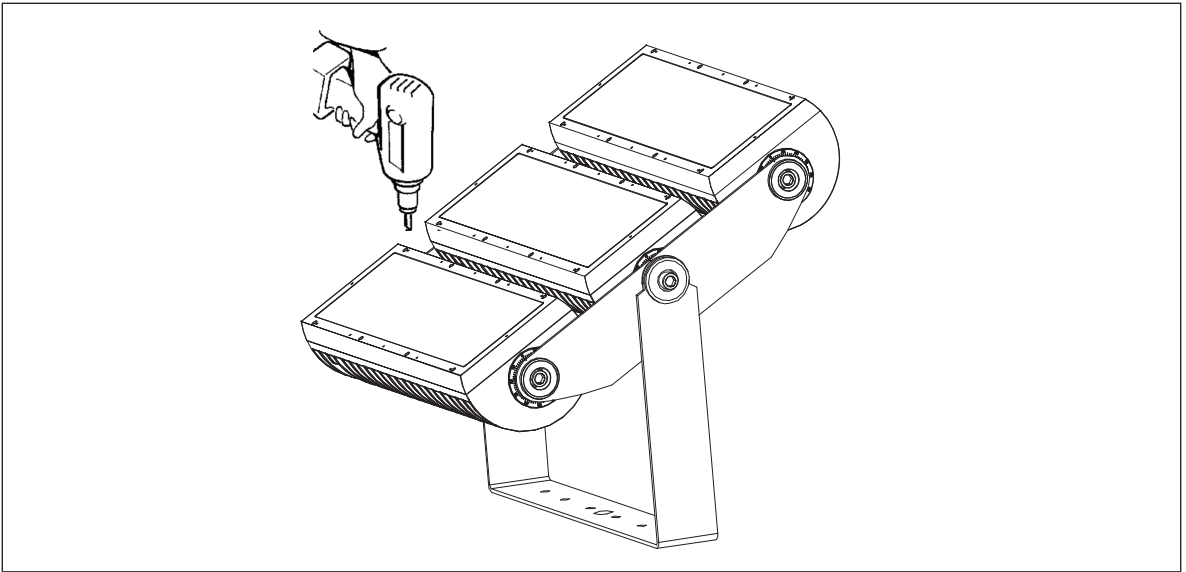

- Loosen the adjusting bolts with 17mm Hex Key, adjust the overall angle of the luminaire and tighten the adjusting bolts.
- Loosen the adjusting bolts with 14mm Hex Key, adjust the single-head exposure angle and tighten the adjusting bolts.



Do not rotate the luminaire more than 180°. Rotating more than 180° may cause the power and/or data cables to bind inside the unit resulting in damage.

FIG.16: Surface Mount Step 3

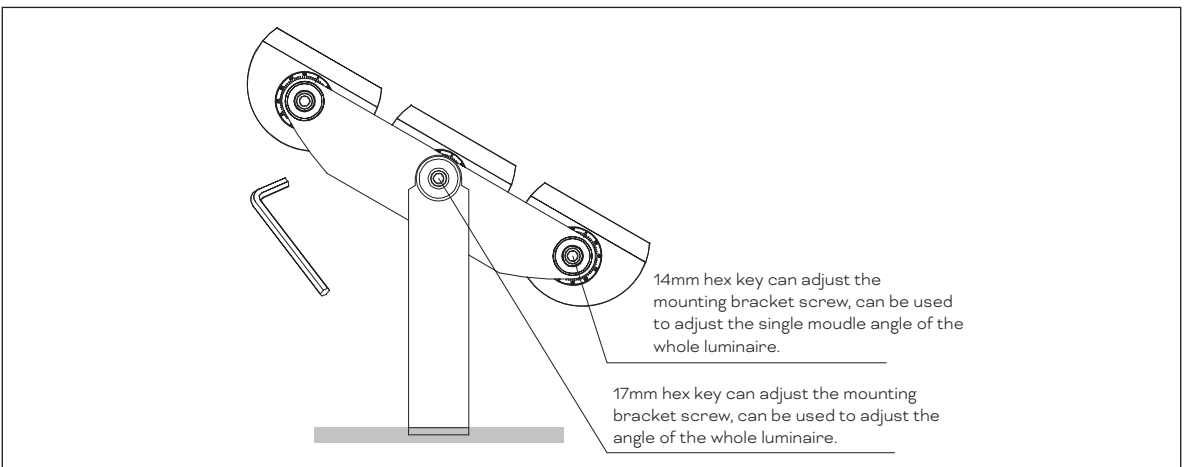

### 3.3.2 Vista Plus Midi / HO Midi Pole Mount Installation (Upright Mounting only)

#### Required Tools

Vista Plus Midi 1x100W Model / Vista Plus HO Midi 1x200W Model	14mm and 17mm Hex Key
Vista Plus Midi 2x100W Model / Vista Plus HO Midi 2x200W Model	14mm and 17mm Hex Key
Vista Plus Midi 3x100W Model / Vista Plus HO Midi 3x200W Model	14mm and 17mm Hex Key

#### Pole Mount Installation

FIG.17: Pole Mount Installation

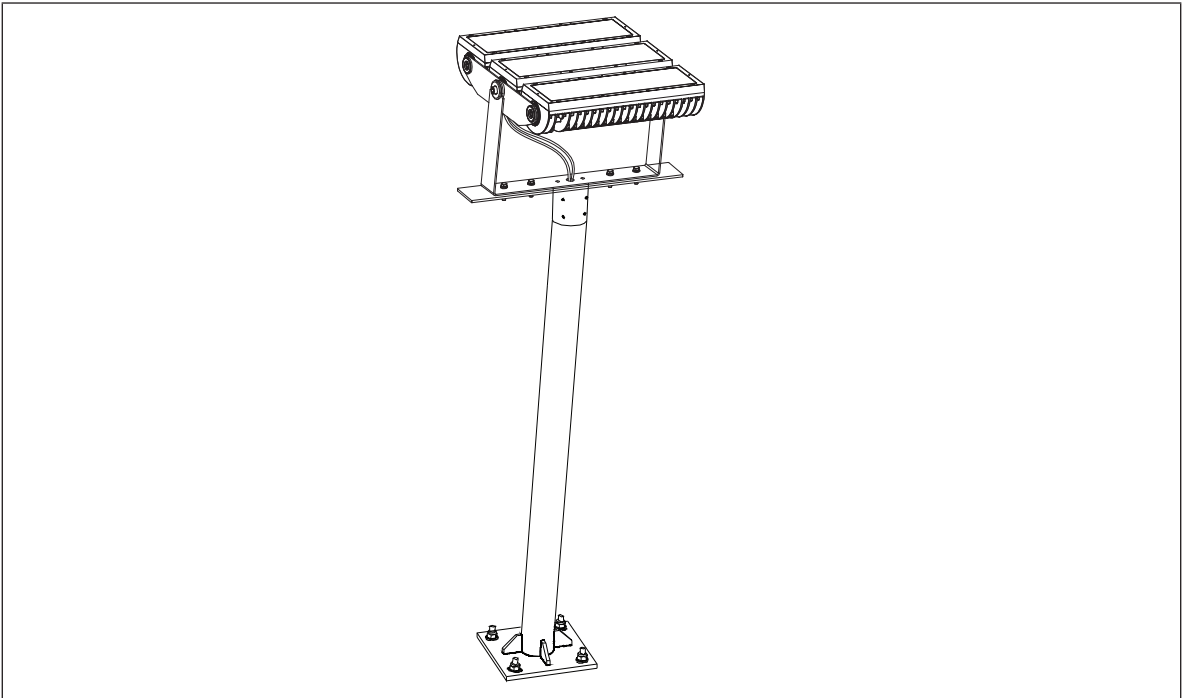

#### Preparation

- Remove the Traxon luminaire from the packaging and place the unit on a level surface.

#### Pole Mounting Steps

- Mark the positions of the 4 mounting holes and then drill 4 x M12 holes with an electric drill. Mount the luminaire bracket to the post mount plate using suitable M12 fixings (e.g. M12 bolt, spring washer and locking M12 nut).

FIG.18: Pole Mounting Step 1

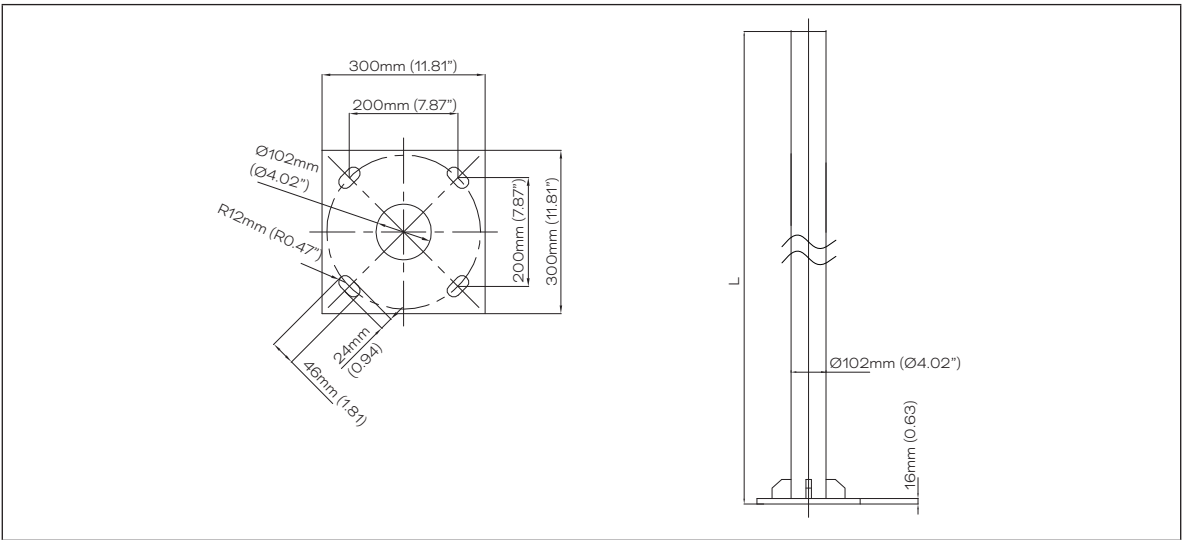

- Fix the inner hexagon screw to fasten the pole mounting supporter onto the pole.

FIG.19: Pole Mounting Step 2

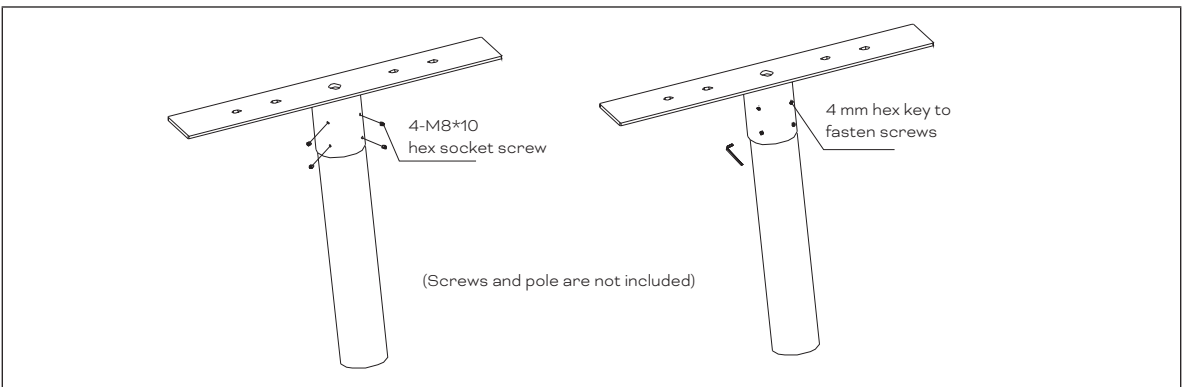

- Pull the power and data cabling through the pole fitting (by others). Install the luminaire onto the pole fitting and secure mounting screws and lock nuts.

FIG.20: Pole Mounting Step 3

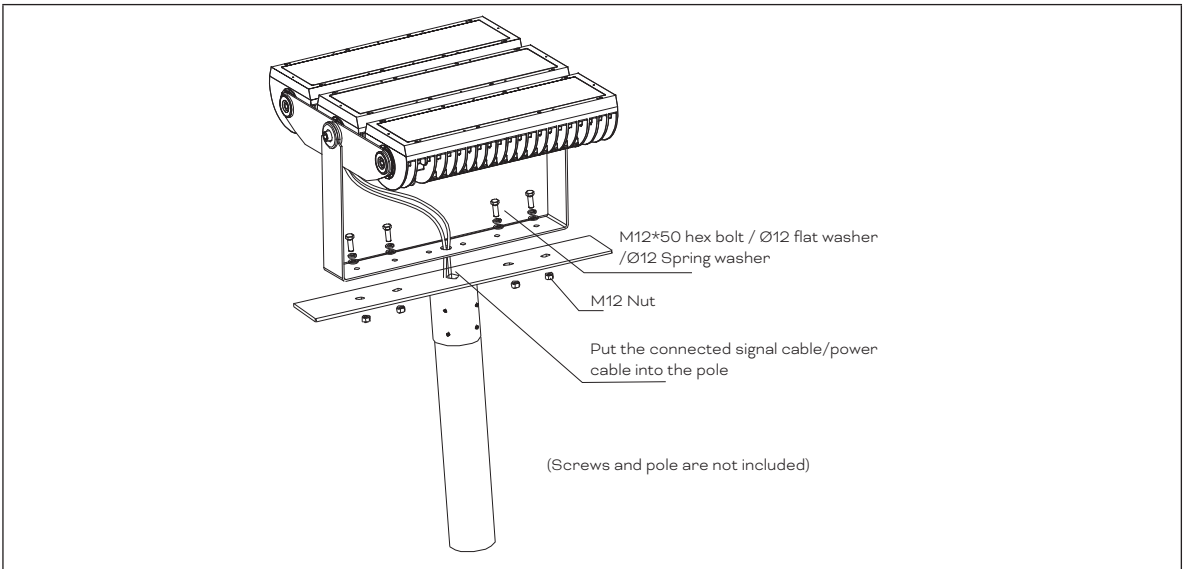

- Fix the luminaire and use a suitable inner Hex Key to adjust the luminaire to a target angle.

FIG.21: Pole Mounting Step 4

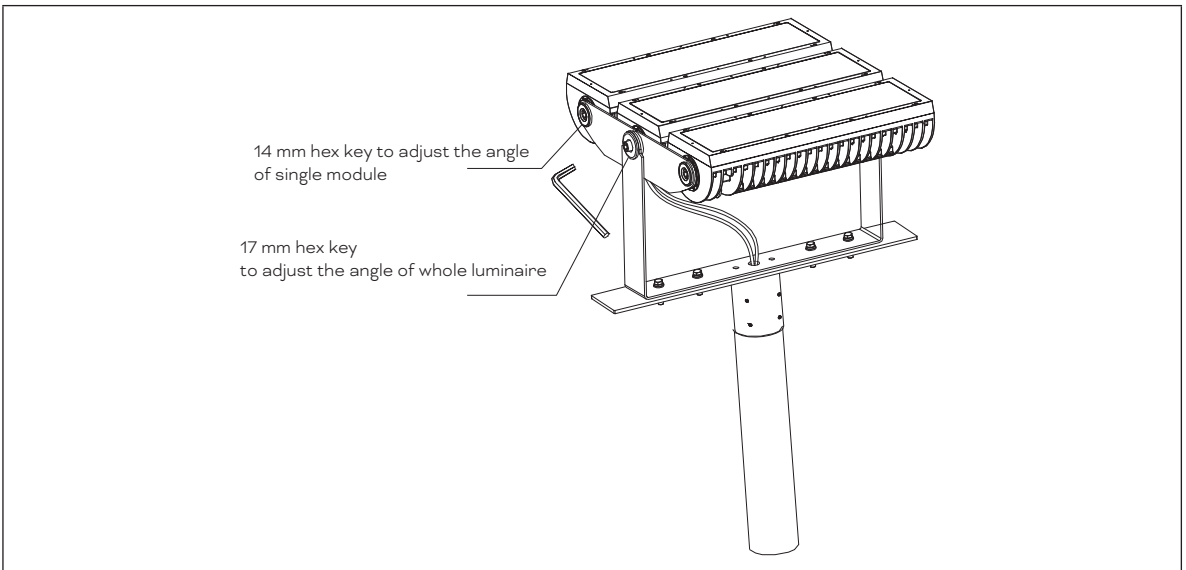

#### Recording the UID (DMX/RDM Model Only)

Each Vista Plus Midi / HO Midi luminaire is marked with a Unique Identifier (UID) on the product label. This UID is used to address the luminaire for correct operation.

Example: 16DC:0834AA0B

AA0B represents the designation shown on the label.

Before completing installation, record each luminaire's UID in a manner similar to the table included at the end of this manual.

FIG.22: UID Location

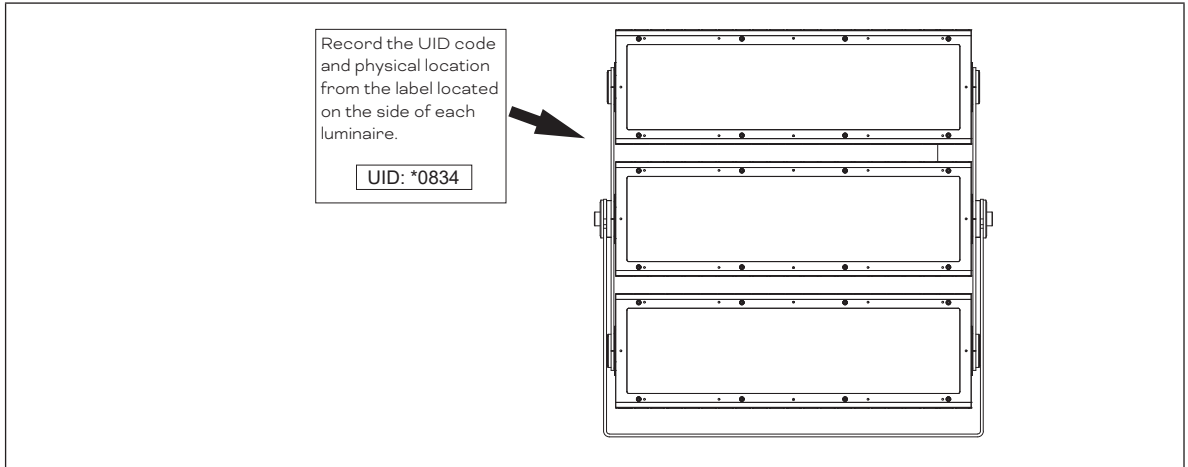

### 3.3.3 Power Wiring

The Vista Plus Midi / HO Midi luminaire is supplied with a 1.8 meter (6 foot) long power feed cable. This cable may be field-cut to the required length by the installer.

**WARNING** Risk of electrical shock. Make sure that the branch circuit is disconnected prior to installation or inspection..

**CAUTION** Make sure that the cable is protected from cuts and abrasions that may result in damage to the outer jacket.

**CAUTION** IP failure induced by stressed/damaged cable entry points during or after installation will void the product warranty.

**NOTICE** A voltage divider is recommended (and may be required by local electrical code) when a single junction box is utilized for termination of the power supply and data cables.

**NOTICE** Cable bend radius must NOT be less than the Minimum Bending Radius (4 X Cable Diameter) as specified by cable manufacturer and the Non-Bendable Length of 5cm (2in) near the cable gland MUST be adhered to. In addition to the Minimum Bending Radius, ensure that 5cm (2in) of cable at the connector junction is kept straight.

### 3.3.4 Glare Shield Installation (Optional Accessory)

#### Required Tools

Vista Plus Midi 1x100W Model / Vista Plus HO Midi 1x200W Model	5mm and 3mm Hex Key
Vista Plus Midi 2x100W Model / Vista Plus HO Midi 2x200W Model	5mm and 3mm Hex Key
Vista Plus Midi 3x100W Model / Vista Plus HO Midi 3x200W Model	5mm and 3mm Hex Key

#### Preparation

- Remove the Traxon luminaire from the packaging and place the unit on a level surface.

FIG.23: Accessories Structure

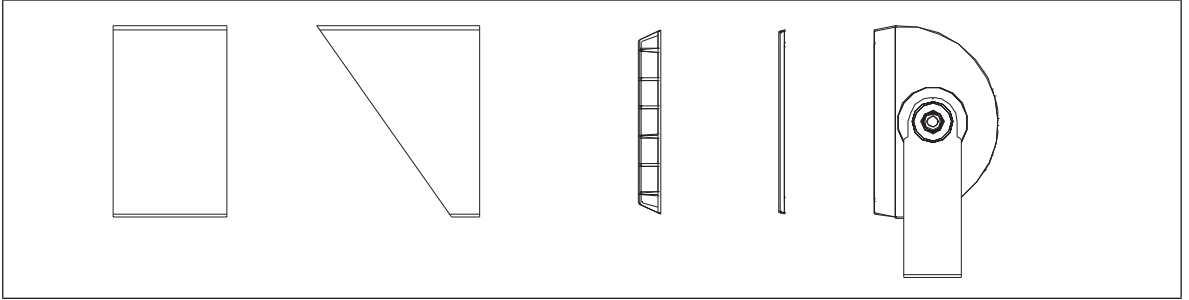

#### Accessories Installation

- Fix the screws as the following picture shows to install the additional accessories as your requirements.

FIG.24: Accessories Structure

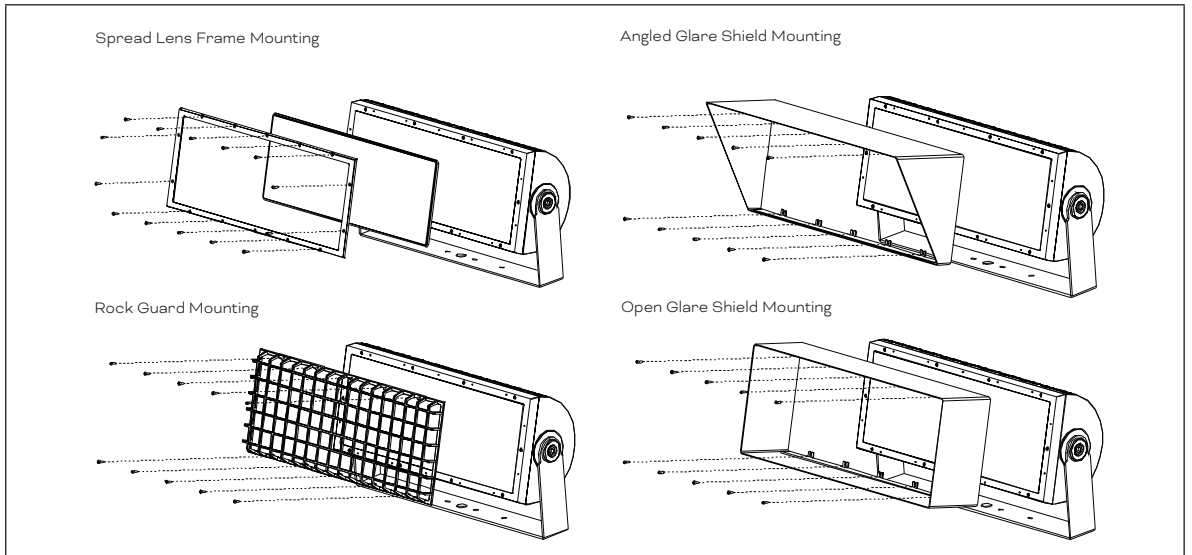

#### **CAUTION**

Ensure that the mounting surface and hardware are suitable for the luminaire weight.

## Final Installation

### **NOTE**

For ease of installation and Safety, the following step may require 2 people to perform. This is largely dependent on the location/orientation of the junction box and the size of the fixture being mounted. All installers should refer to their occupational safety and best practice guidelines when performing these tasks.

- Install the luminaire onto the mounting bracket and secure the set screws and lock nuts.

### **CAUTION**

Ensure that the power and data cabling is routed so that the luminaire mounting interface does not crush the power and/or data cable jacketing.

- Tighten both set screws so that each screw engages securely in the surface mount bracket groove.

### **CAUTION**

Both set screws must engage within the groove. Failure of the set screws to engage the groove could result in the luminaire separating from the surface mount bracket.

- Tighten both lock nuts over the set screws. Grasp the luminaire body and rotate it back and forth on the mounting bracket to ensure that the fixture is securely fastened.

### **CAUTION**

Do not rotate the luminaire more than 180 degrees. Rotating more than 180 degrees may cause the power and/or data cables to bind inside the unit resulting in damage.

# 4. System Configuration

## 4.1 Data Wiring

The Vista Plus Midi / HO Midi luminaire is supplied with a 1.8 meter (6 foot) long data cable. This cable may be field-cut to the required length by the installer.

The Vista Plus Midi / HO Midi luminaire utilizes a “daisy chain” wiring topology for DMX data communication. Data connections are made via the DMX input and output wiring pairs in the data cable. Utilization of a “star” wiring topology (via t-taps, y-cables, etc.) is not permitted.

Installed data cabling shall conform to the requirements outlined in ANSI E1.11 Entertainment Technology – USITT DMX512-A, Asynchronous Serial Digital Data Transmission Standard for Controlling Lighting Equipment and Accessories. All cabling shall utilize stranded conductors. **Solid core conductors shall not be used and can result in denial of warranty.**

A maximum of 32 Traxon luminaires may be connected to a DMX data line. The maximum overall data line length (from DMX controller to the last unit in the daisy chain) is 100m (328ft).

**WARNING** Risk of electrical shock. Make sure that the branch circuit is disconnected prior to installation or inspection..

**CAUTION** Make sure that the cable is protected from cuts and abrasions that may result in damage to the outer jacket.

**CAUTION** IP failure induced by stressed/damaged cable entry points during or after installation will void the product warranty.

**NOTICE** A voltage divider is recommended (and may be required by local electrical code) when a single junction box is utilized for termination of the power supply and data cables.

**NOTICE** Cable bend radius must NOT be less than the Minimum Bending Radius (4 X Cable Diameter) as specified by cable manufacturer and the Non-Bendable Length of 5cm (2in) near the cable gland MUST be adhered to. In addition to the Minimum Bending Radius, ensure that 5cm (2in) of cable at the connector junction is kept straight.

### Installation Steps

1. Determine the required length of data cable. Make sure to account for cable management (routing, drip loops, etc.) prior to removal of unneeded cable.
2. Make sure that there is sufficient cable to account for thermal expansion and contraction.
3. Insert the data cable into the pole. The cable entry points shall be protected with fittings suitable for maintaining a water-tight installation.

**NOTICE** The use of RTV silicone is required at all terminal box penetration points.

4. Connect the luminaire DMX input and output conductors to the contractor installed DMX wiring.

## **NOTICE**

All data wire connections shall be made using cage clamp style connectors included in the termination kit (ordered separately). Wire nut connections of the data conductors shall not be used and will void the warranty.

5. Install the termination resistor (included in the termination kit) between the Data - and Data + conductors on the last unit in the control. See Wiring Details for specific wire connections.

## **NOTICE**

Termination is required for proper operation and shall be applied at the last unit of the daisy chain only. Failure to apply termination correctly will void the warranty.

FIG.25: DMX Termination Detail

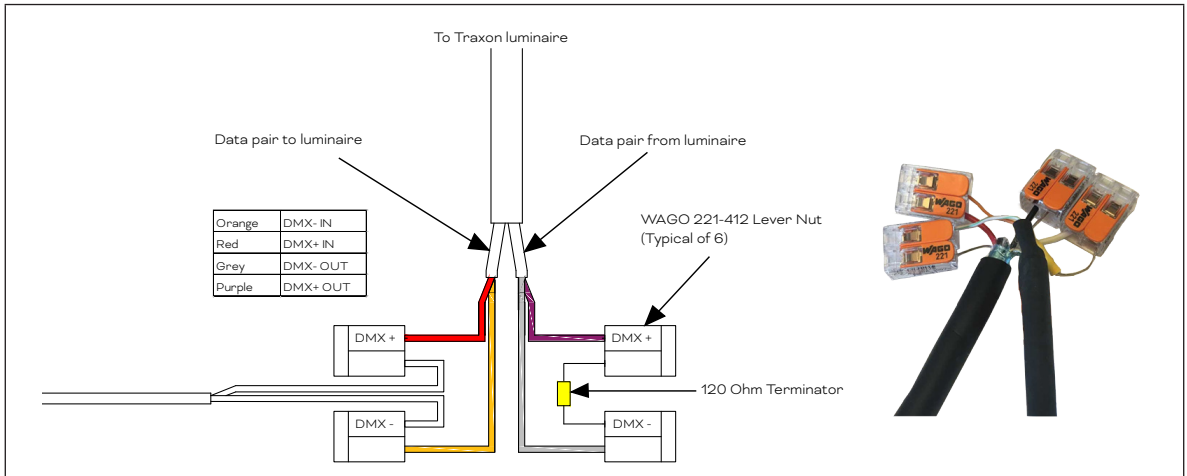

## **NOTE**

- Maintain data pair wire twist at all connection points.
- To prevent short circuits, do not strip more conductor insulation than required for connection.
- The use of wire nuts is not acceptable and will void the warranty.
- Data termination shall be made in weatherproof enclosure by others. Use suitable cable glands and apply RTV silicone at all entry points.

## **NOTICE**

Data shall enter each luminaire using the DMX In wire pair (Orange and Red conductors). A 120 Ohm termination resistor shall be installed on the DMX Out wire pair (between Grey and Purple conductors). Failure to terminate at the last luminaire will void the warranty and may result in control issues.

FIG.26: Wiring Diagram Vista Plus Midi 1x100 / Vista Plus HO Midi 1x200W

- Vista Plus fixtures ship with two cable whips: One cable whip for power input, consisting of two wires plus a ground, and one cable whip for DMX512 RDM input/output.
- No more than (32) fixtures on a single DMX512 link, max. 100m total (source to last fixture). Each fixture has 18m DMX data cable (total 3.6m DMX in and DMX out), it should be included in the 100m total calculation.
- Each DMX512 link must be properly terminated to prevent signal reflections.
- Data cabling from DMX source to first fixture and between subsequent Vista Plus fixtures shall be Cat5e UTP or higher (stranded type only) or other cable type suitable for DMX communication. Consult DMX standard for additional guidance.

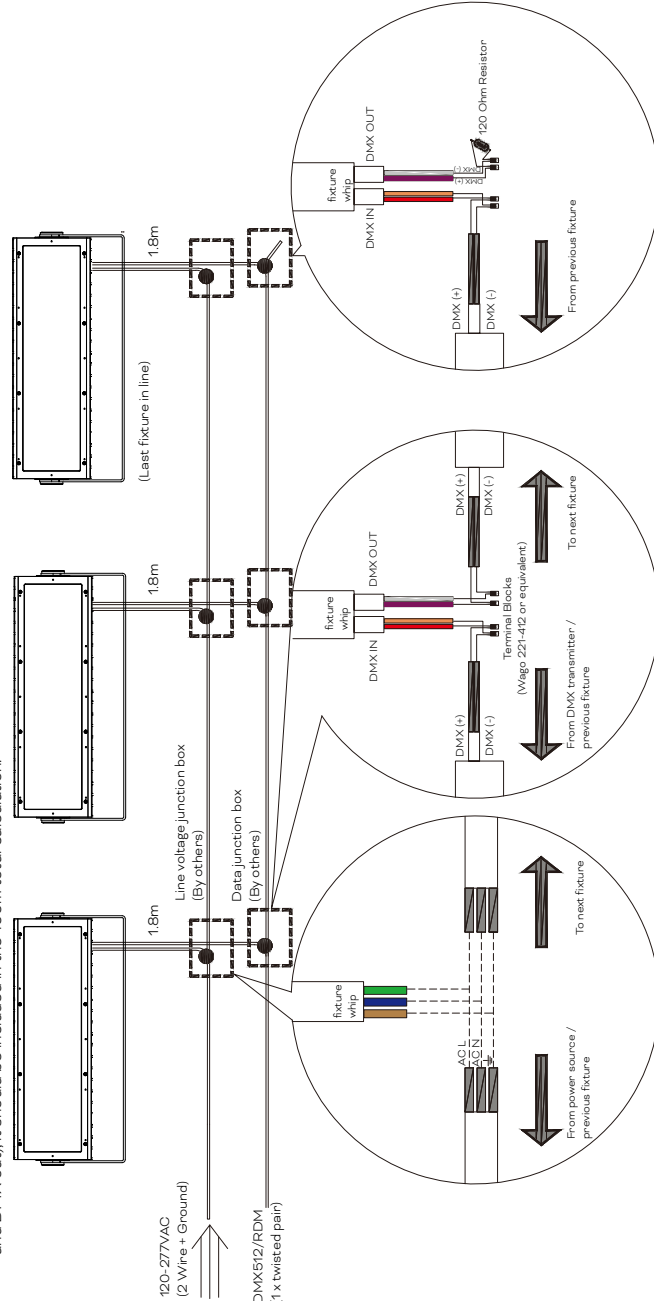

**General Notes**

- All data cabling must adhere to ANSI E11.1-2008 (R2013) – Entertainment Technology – USITT DMX512-A, Asynchronous Serial Digital Data Transmission Standard for Controlling Lighting Equipment and Accessories.
- Fixture is RDM compatible.
- Fixtures allow a universal input of 120V AC to 277V AC.
- Data termination shall utilize cage clamp terminal blocks, or equivalent. Wire nuts are not permissible and will void warranty.
- The method of line voltage termination, both for data and power, is at the discretion of the installing contractor, and/or engineer. Splicing and/or joining of cables must adhere to all applicable electrical codes.
- Cables must be spliced/joined in a weatherproof enclosure/junction box, which is to be properly rated and provided by others.

FIG.27: Wiring Diagram Vista Plus Midi 2x100 / Vista Plus HO Midi 2x200W

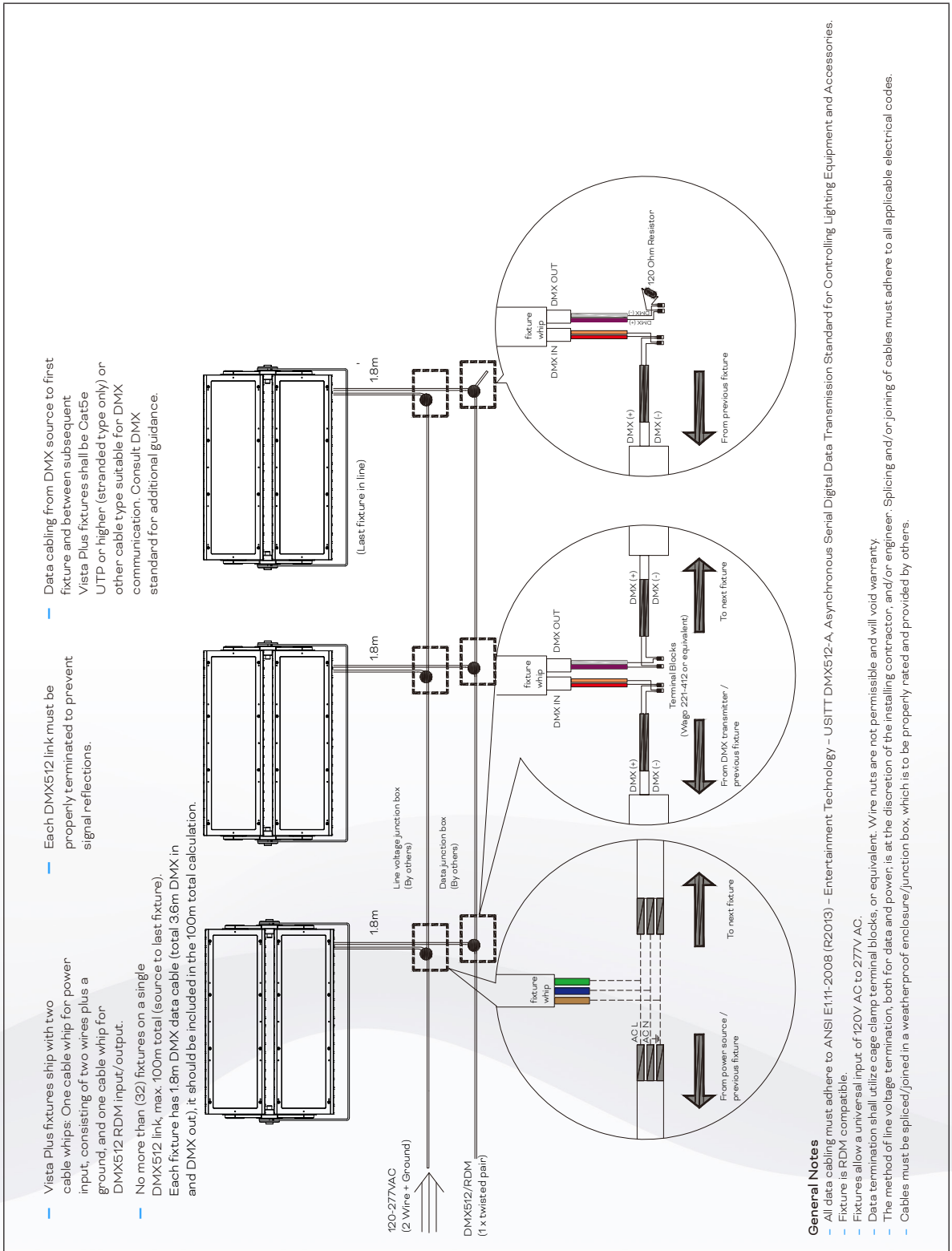

- General Notes**
- All data cabling must adhere to ANSI E111-2008 (R2013) – Entertainment Technology – USITT DMX512-A, Asynchronous Serial Digital Data Transmission Standard for Controlling Lighting Equipment and Accessories.
  - Fixture is RDM compatible.
  - Fixtures allow a universal input of 120V AC to 277V AC.
  - Data termination shall utilize cage clamp terminal blocks, or equivalent. Wire nuts are not permissible and will void warranty.
  - The method of line voltage termination, both for data and power, is at the discretion of the installing contractor, and/or engineer. Splicing and/or joining of cables must adhere to all applicable electrical codes.
  - Cables must be spliced/joined in a weatherproof enclosure/junction box, which is to be properly rated and provided by others.

FIG.28: Wiring Diagram Vista Plus Midi 3x100 / Vista Plus HO Midi 3x200W

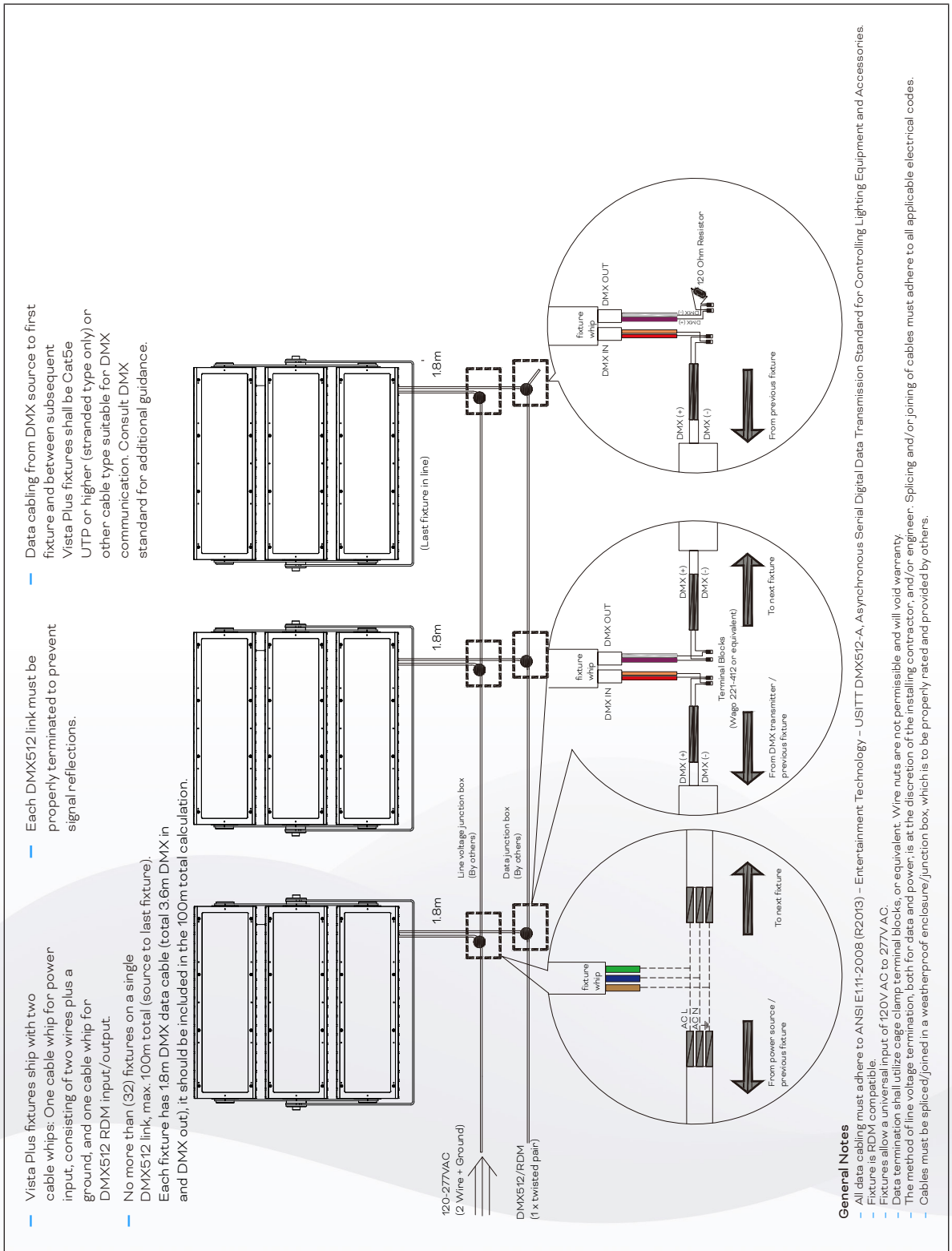

## 4.2 Luminaire Addressing and Control

The Vista Plus 1x100W / 2x100W / 3x100W luminaire utilizes 4 DMX channels for the RGBW unit, and 1 DMX channel for the White units and for the Vista Plus 1x200W / 2x200W / 3x200W, utilizes 8 DMX channels for the RGBW unit, and 2 DMX channel for the White units.

The Vista Plus Midi / HO Midi luminaires are shipped with a default DMX address of 001. For installations where independent control of luminaires is required, the DMX address will need to be modified using a controller that supports Remote Device Management (RDM).

- Connect an RDM capable control device to the DMX line ahead of the first luminaire.
- Enable RDM discovery per the instructions of the controller manufacturer.
- The controller will discover available Traxon luminaires. These luminaires can be identified by the prefix 16DC in each unit's UID.
- Using the RDM identify function, locate a single unit in the installation. The associated luminaire will flash.
- Note the physical location of the flashing unit and then disable the identify function.
- Determine the desired address for the identified luminaire and enter it in the address field of the RDM controller.
- Continue the above process until all units have been addressed.
- Record the UID data and associated addresses at the end of this document.
- Test each luminaire to verify correct addressing prior to completing installation.

### Traxon Power-Up and Loss of Data Behavior

The Vista Plus Midi / HO Midi luminaire will exhibit the following behavior upon power-up and loss of DMX data:

Power-Up with no DMX data present	Luminaire will illuminate at full power
Power-Up with DMX data present	Luminaire will respond based on the DMX values being received
Loss of DMX data	Luminaire will hold the last valid DMX values received until a power cycle or until DMX is restored.

### DMX Channel Functions

#### RGBW Unit

DMX Channel	Function
1	Red Intensity
2	Green Intensity
3	Blue Intensity
4	White Intensity

#### White Unit

DMX Channel	Function
1	White Intensity

## Supported RDM Parameters

Parameter ID	Description	Default Value	Note
0x00F0	DMX Start Address	1	
0x1000	Identify Device	0	Changing value to 1 will cause fixture to flash
0x0081	Manufacturer Label	Traxon Technologies	Read Only Parameter
0x0082	Device Label	Traxon xx	
0x0200	Sensor Definition	N/A	Read Only Parameter
0x0201	Sensor Value	N/A	Read Only Parameter

## Supported RDM Sensors

Sensor Number	Sensor Description	Unit of Measure	Safe Operating Range
#0	Driver Temperature	Celsius	
#1	Drive Voltage	DC Volts	
#2	Driver Current	mA	
#3	On-Line Time	ks	

## 5. Care and Maintenance

Traxon products are of superior design and quality and should be treated with care. The recommendations below will help fulfill any warranty obligations and gain good use and longevity from the products.

- Do not attempt or use the product(s) until you read and understand the installation instructions. Failure to adhere to these instructions could result in serious injury or property damage.
- Do not use product(s) if cables are damaged.
- Do not connect cables and connectors when wet or in wet area. Moisture on bare connectors can cause electric shock and damage to product(s).
- Do not use product(s) in extreme heat environment. Ensure there is sufficient airflow and use cool air circulation if required.
- Do not drop, knock, or shake product(s). Rough handling can damage the electronics and void the warranty.
- Do not use harsh chemicals, cleaning solvents, or strong detergents to clean products. Wipe with a damp cloth on housings and a dry cloth on electronics to remove dirt or dust.
- Do not attempt to service or repair the product(s) unless done by an authorized service personnel. Contact your local Traxon office or distributor for details.
- If the product is not working as specified, please contact your nearest authorized service center or Traxon Technologies office for assistance.
- The light source of this luminaire is not replaceable; when the light source reaches its end of life the whole luminaire shall be replaced.

## 6. Technical Specification

For detailed product specifications, please refer to the product data sheet or [www.traxon-ecue.com](http://www.traxon-ecue.com).

As with all electronic devices, LED output degrades over time - a term called lumen depreciation. This also explains why it is nearly impossible to expect photometric performances of two LED products with different service life spans to be the same. The rate of LED degradation is a complex function of many factors such as operating efficiency, duration of continuous operation, and operating conditions (e.g. ambient temperature).

Because LEDs are semiconductor devices, their performances are subject to inherent variability commonly found in semiconductor industry. To improve consistency in performance across the same product, LED manufacturers “sort” LEDs into bins according to different preset parameters, such as forward driving voltage, illumination, etc. Whereas binning is a sorting function, it is not a correction process. Inherent variability in the manufacturing process always results in different binning distributions according to different production lots. Traxon uses automatically binned LEDs on its products, thereby minimizing output variations within the model range.

## 7. Troubleshooting



**CAUTION:** Ensure power supply is OFF when disconnecting / connecting cables.

Problem	Cause	Possible Solutions
Product does NOT light up after installation	Incorrect power connection	<ul style="list-style-type: none"><li>— Check Mains Power</li><li>— Check power supply leads and wire connections</li><li>— Ensure output wires are connected with proper polarity</li><li>— Check if LED Engine's secondary output is working as specified.</li></ul>
Shadowing	Light source covered	<ul style="list-style-type: none"><li>— Check for cables, wires or unwanted debris covering LED light source</li></ul>
Modules are dim	Excess products connected	<ul style="list-style-type: none"><li>— Ensure the power supplies are not overloaded due to an excess of products connected</li></ul>
Flickering	Incorrect power input/Excess products connected	<ul style="list-style-type: none"><li>— Ensure the input voltage is correct</li><li>— Ensure the power supplies are not overloaded due to an excess of products connected</li></ul>

If problems persist or the product is not working as specified, please contact your Traxon Technologies office for assistance.

## 8. Warranty Statement

Traxon Technologies warrants its Products against material or workmanship defects for a period of five (5) years from date of invoicing, provided that the purchased items are used under the conditions stated in this user manual.

Please refer [www.traxon-ecue.com](http://www.traxon-ecue.com) for all warranty terms and conditions.

# 9. Appendix

## UID/Address Recording Table

Luminaire	UID	DMX Address	DMX Universe #	Fixture Mounting Location	Note
Unit 1					
Unit 2					
Unit 3					
Unit 4					
Unit 5					
Unit 6					
Unit 7					
Unit 8					
Unit 9					
Unit 10					
Unit 11					
Unit 12					
Unit 13					
Unit 14					
Unit 15					
Unit 16					
Unit 17					
Unit 18					
Unit 19					
Unit 20					
Unit 21					
Unit 22					
Unit 23					
Unit 24					
Unit 25					
Unit 26					
Unit 27					
Unit 28					
Unit 29					
Unit 30					
Unit 31					
Unit 32					

### **NOTE**

Do not exceed 32 luminaires on a single DMX data line.  
Termination resistor must be installed at the last luminaire only.



# TRAXON

TRAXON | e3cue

Please check for the latest updates and changes on the Traxon website.

© 2026 TRAXON TECHNOLOGIES. ALL RIGHTS RESERVED.

[www.traxon-ecue.com](http://www.traxon-ecue.com)