

ecue

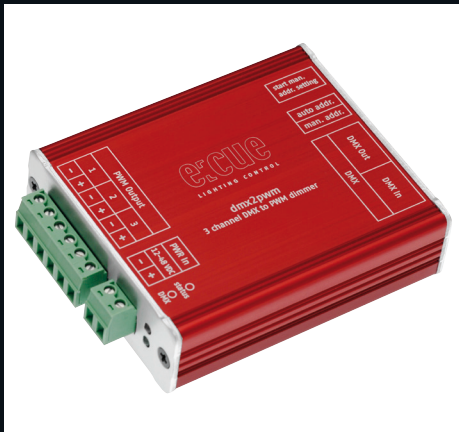

TRAXON | ecue
MEMBER OF PROSPERITY GROUP

AA623900135



ecue DMX2PWM 3CH

Information for Use

Read the Information for Use and the Safety Instructions carefully. Subject to modification without prior notice.

Typographical and other errors do not justify any claim for damages. Modification of the product is prohibited.

This manual is designed for electricians, system administrators, and product users.

All product names and trademarks mentioned in this manual are trademarks of their respective owners.

Except for internal use, relinquishment of the instructions to a third party, duplication in any type or form - also extracts - as well as exploitation and / or communication of the contents is not permitted.

Downloads and more information at:
www.ecue.com

Edition:

17.07.23 [EN_DM2PWM_3ch_Setup_v2p0]

Published by:

Traxon Technologies Europe GmbH
Karl-Schurz-Strasse 38
33100 Paderborn, Germany

©2023 Traxon Technologies Europe GmbH
All rights reserved

Traxon Technologies Europe GmbH
Sales Operations
Karl-Schurz-Str. 38
33100 Paderborn, Germany
+49 5251 54648-0
support@ecue.com

Table of Contents

1	Safety instructions	03
1.1	Symbols	03
1.2	General instructions	03
2	General device description	04
2.1	Delivery content	04
2.2	Product specifications	05
3	General remarks	06
3.1	Transport	06
3.2	Unpacking	06
3.3	Warranty regulations	06
3.4	Maintenance and Repair	06
3.5	Disposal	06
3.6	Support	06
4	Installation	07
5	DMX	08
5.1	Pin assignment	08
6	Device setup	09
6.1	Manual addressing	09
6.2	Auto addressing	09
6.3	External power source	09
7	Status LEDs	10
8	Dimming curve	10
9	Dismounting	11
10	Certifications	11
11	Dimensions	12

1 Safety instructions

Please read the safety instructions, provided in a separate manual, carefully. Make sure that the environmental, mounting, and installation prerequisites are met. This manual should be kept at a safe place and in reach of the device.

1.1 Symbols



The exclamation mark warns about possible damage of the device itself, to connected devices, and to the user.



The information symbol gives general hints and informs about handling and procedures for use of the device.

1.2 General instructions



- Device components inside the system can reach high temperatures! To avoid burns, allow the unit to cool for at least 20 minutes before unmounting or repair.



- Only use the device in compliance with the environmental conditions specified and watch the technical characteristics. Otherwise the unit may be damaged or malfunction will happen.
- To prevent the device from overheating, only operate it in well-ventilated environment. Ventilation may not be obstructed. Do not install next to heat emitting sources or in a place subject to direct sunlight. Overheating damages the device.
- Installation and maintenance of this product must be performed by individuals who are knowledgeable about the procedures, precautions and hazards associated with the product.



- Do not route network, DMX or any other communication line together with power lines. Data traffic or functions can be disturbed.
- We strongly recommend keeping the dI/dt^* loop as small as possible. Install the dimmers, PSUs, and LED modules as close together as possible.
- The high dI/dt cables shall not be installed close to the DMX data cables.
- For DMX and power, it is recommended to use shielded cables only and to connect the shield to earth.

* dI/dt means high current pulses caused by PWM dimming. These pulses may interfere with the DMX signal.

2 General device description

The e:cue DMX2PWM LED dimmer is a 3 channel dimmer for use with constant voltage fixtures. The input voltage is variable from 12 ... 48 VDC and each output channel has a maximum output current of 2.5 A. Each output channel can be individually controlled via DMX, a DMX output allows chaining of multiple devices. The option to either manually or automatically address the dimmer on a DMX channel provides a simple solution for small to complex control scenarios. The reverse supply protection and self-resetting overcurrent protection avoid malfunction and damage caused by wrong connections. Two status LEDs show the status of the dimmer and the status of the incoming DMX signal. Power input and output are on screw terminals, that are also used for connecting the DMX inputs and outputs.

Main features

- LED dimming using pulse width modulation (PWM)
- For use with constant voltage fixtures
- Three outputs individually controllable via DMX
- Two user selectable DMX addressing modes:
auto addressing or manual addressing
- Input voltage range: 12 ... 48 VDC
- Max. output current of 2.5 A per channel for 0 ... 50 °C ambient temperature
- Max. output current of 2.0 A per channel for 50 ... 60 °C ambient temperature
- DMX in/out
- Low side switching
- Reverse supply protection
- 14 bit PWM resolution
- Overcurrent protection (self resetting)
- Two status LEDs

2.1 Delivery content

Delivery content for the e:cue DMX2PWM 3CH (AA623900135):

1. DMX2PWM 3ch dimmer
2. Welcome note
3. 2-pin screw terminal plug (power supply)
4. 6-pin screw terminal plug (LED connection)



2.2 Product specifications

Dimensions (W x H x D)	94 x 71.5 x 24 mm/ 3.66 x 2.81 x 0.94 inch
Weight	0.08 kg / 0.18 lbs
Power supply	12 ... 48 V DC (screw terminals)
Power consumption	0.6 W (idle, all channels off, DMX connected)
Max. output current	2.5 A (overcurrent protection, ±10% @ 0 ... 50 °C / 32 ... 122 °F ambient temperature 2.0 A (overcurrent protection, ±10% @ 50 ... 60 °C / 122 ... 140 °F ambient temperature
Max. output load capacitance	1 µF
Over-current retry delay	1 sec.
Minimum on time	2.5 µs
PWM frequency	488 Hz
PWM resolution	14 bit (optimized dimming curve calculated from 8 bit DMX value)
Operating temperature	0 ... 50 °C/32 ... 122 °F
Storage temperature	-20 ... 85 °C/-4 ... 185 °F
Electrical safety	SELV
Op./storage humidity	0 ... 90% non-condensing
Protection Class	IP20
Housing material	Aluminium
Certification	CE, ETL, UKCA

Interface specifications

Inputs	DMX512 (RJ45)
Outputs	DMX512 (RJ45) 3 LED output channels (screw term. + connector: identical to input voltage - connector: low side PWM switch
Data protocols	DMX512-A and e:pix
Max. devices in a chain	32 (depends on cable length and quality)
Max. wire cross section	1.5 mm ² (screw terminals, power supply and PWM outputs)

Always select the power supply output voltage accordingly to your LED fixture input voltage!

12 V PSU for 12 V LED

24 V PSU for 24 V LED

48 V PSU for 48 V LED



3 General remarks

3.1 Transport

Only transport the device in its original packaging. This protects the device from damage.

3.2 Unpacking

Only unpack the e:cue DMX2PWM 3CH at its installation location. To protect the device against condensation water, unpack it and wait until all moisture remaining in the device has evaporated.

Condensation can occur when the device is moved from a cold to a warm location. Keep the packaging for use in case of further transport. Inspect all parts for completeness regarding chapter „2.1 Delivery content“ on page 04. If there is apparent damage to the device or parts are missing from the delivery scope, please contact the Traxon e:cue support service.

3.3 Warranty regulations

Depending on the product, warranty regulations are of different duration. The warranty time is usually noted in the quote and in the order confirmation. See www.traxon-ecue.com/terms-and-conditions for details. Legal warranty regulations apply in any case.

3.4 Maintenance and Repair

This device requires no maintenance.



- Before dismounting, appropriate measures must be taken to protect the respective components against damage caused by electrostatic discharge (ESD protection).
- Do not try to repair the device. Return it to your Traxon e:cue distributor for replacement or repair.

3.5 Disposal



Batteries and technical appliances must not be disposed of with domestic waste, but should be handed in at the appropriate collection and disposal points.

The proper disposal of packing materials and of the device is the responsibility of the respective user and for his account; in all other matters, the retrieval obligation for packing materials and the device is subject to the statutory regulations.

3.6 Support

In case of technical problems or questions regarding installation and repair please contact:

Traxon Technologies Europe GmbH
 Customer Service
 Karl-Schurz-Str. 38
 33100 Paderborn, Germany
 +49 (5251) 54648-0
support@ecue.com

4 Installation

The PWM switching node is designed as a low-side switch and is able to handle a maximum current of 2.5 A. Each output channel is short circuit protected. As soon as an over-current or short circuit situation is detected, the switch of the corresponding channel will immediately shut down. The yellow STATUS LED is blinking to signal the over-current error. The dimmer tests the output repeatedly if the over-current still exists. It will re-enable the output as soon as the over-current or short circuit is removed.

For use of the DMX2PWM dimmer device a DC power supply unit is necessary. The choice of the power supply voltage only depends on the supply voltage of your LED fixtures, but must remain in the range from 12 V to 48 V DC. Please consider that the power supply must be able to provide the current for the connected LED fixtures and the DMX2PWM dimmer. Multiple LED fixtures where each one needs a different voltage level cannot be used with one dimmer device at the same time.

Always select the power supply output voltage accordingly to your LED fixture input voltage: 12 V PSU for 12 V LEDs, 24 V PSU for 24 V LEDs, 48 V PSU for 48 V LEDs.

The “+” line of the Power supply connection (PWR In) is directly routed to the “+” connection of each PWM output. The following picture shows the basic connection scheme:

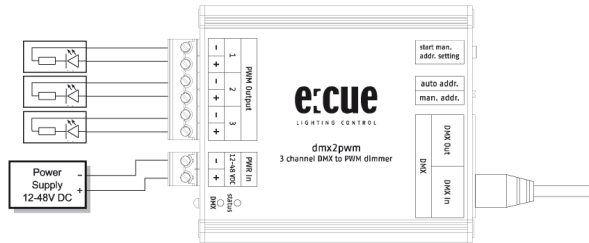

The advantage of the above shown type of connection is the reverse supply protection of all LED fixtures and the dimmer itself. Alternatively it is also possible to connect LED fixtures as shown in the figure below.

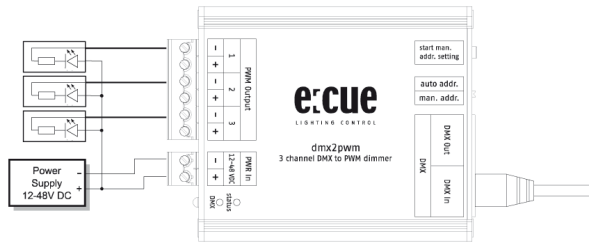

Due to the PWM dimming concept, the current sourcing the LED modules is being switched on and off with a high frequency by the dimmer. The cables which carry the current pulses (di/dt cables) shall be kept as a short as possible to not cause interferences or radiation. It is strongly recommended to keep data cables, such as DMX, away from the dashed marked cables shown in the picture below. The use of shielded cables is also recommended.

The following pictures shows the di/dt cabling: the dashed lines as the high current loop (high di/dt):

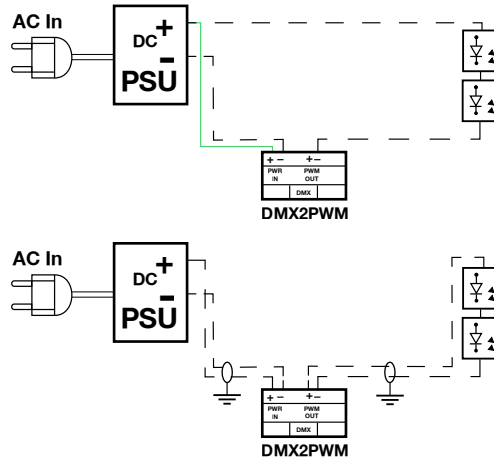

! Always select the power supply output voltage accordingly to your LED fixture input voltage. Make sure that the power supply cables are specified to carry the complete amount of current needed by the connected LED fixtures. We recommend to install the dimmers, PSUs, and LED modules as close together as possible. We recommend to not install the power cable close to the DMX data cable.

5 DMX

A DMX master must be attached to the DMX-In connector. If a valid DMX signal is detected by the DMX2PWM, the green DMX LED is on.

Use shielded cables only.

To connect multiple devices in a chain, connect the DMX Out port of the first device to the DMX-In port of the next device. For details about setting up a DMX address, please refer to the corresponding chapter.

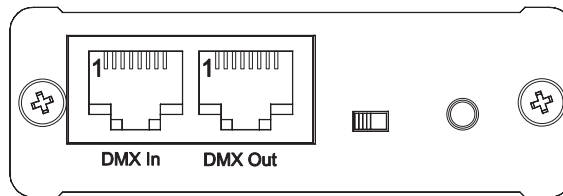

5.1 Pin assignment

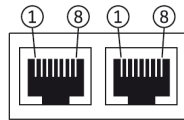

Pin	Connection
1	DMX-
2	DMX+
3, 7	Gnd

6 Device setup

6.1 Manual addressing

The DMX2PWM dimmer has no switches for setting up the DMX address, instead you configure the first DMX address for the device by sending a DMX data frame. To use manual addressing, the switch must be set to MAN. ADDR.. When you press the button START for at least one second and then release it, the DMX LED starts blinking. The device now listens and waits for a DMX configuration data frame. The first received DMX data byte which is not zero is used as the device's base address (address of PWM output 1).

Example:

- The first received DMX data byte other than zero is located at address 11 when the device is in listening mode. Address 11 will now be stored as start address for PWM output channel 1. Channels 2 and 3 are then automatically configured the address 12 and 13. The base address is stored into a non-volatile memory so that address is present after repowering the device.

To abort the listening mode without any changes, simply press the button for less than one second. The STATUS LED stops blinking.

To reset the device to base address 1 without sending a configuration data frame, press and hold the button for one second. The DMX LED starts blinking. Then press and hold the button for one second again. The DMX LED stops blinking and the address is set back to 1. It is of no importance whether the DMX cable is connected or not.

6.2 Auto addressing

Auto addressing mode should be used when connecting several DMX2PWM dimmers in a chain. The first device in a chain occupies the DMX addresses 1, 2 and 3. The next one, which is connected to the DMX-Out connector of the previous one, uses addresses 4, 5 and 6 and so on.

If a base address is already set (see manual address setting), the device also uses this address in auto addressing mode as its base address.

Examples:

- The first device in the chain has the base address 6 (and also occupies addresses 7 and 8), the next device has the base address 9.
- The first device in the chain has been configured for base address 2 and the next device has the base address 4. The result is that the first device occupies the address 2, 3 and 4 and the next device uses address 8, 9 and 10.

To avoid confusion when using the auto addressing mode it is recommended to reset the base addresses of all devices to 1.

6.3 External power source

The housing version of the DMX2PWM is equipped with a jumper (J1) to enable power sourcing on the DMX-In connector pin 5. The default setting at delivery is off (position 2-3). When enabled (position 1-2), the power supply is directly routed to pin 5 of the RJ45 connector. This is especially useful when using the DMX2PWM in combination with the e:cue Glass Touch user terminals. No other additional power supply is needed.



7 Status LEDs

LED	Description
DMX off or flickering	No DMX signal recognized or not connected
DMX on	DMX present
DMX blinking	Awaiting DMX data frame for manual address setting
STATUS off	Power supply not connected
STATUS on	Normal operation
STATUS blinking	Overcurrent detected on one or more channels

8 Dimming curve

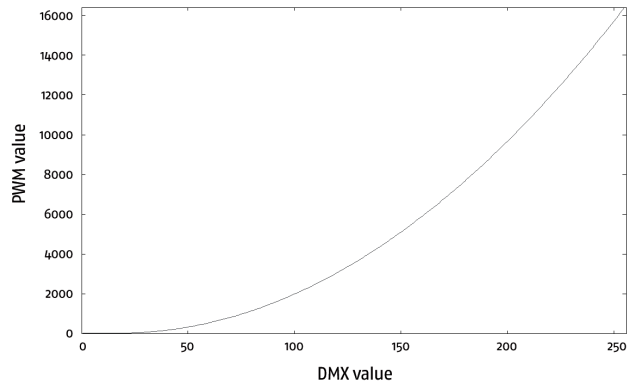

The dimming of the LEDs is accomplished by a pulse width modulation with a basic frequency of $f=488$ Hz. Due to the 14 bit PWM resolution, the “On-time” can be adjusted in 125 ns steps. To achieve a more “linear” impression of the LED’s brightness, a translation from the 8 bit DMX value to the 14 bit PWM resolution in form of a dimming curve is implemented.

The following picture shows the principle of PWM dimming. Please keep in mind the DMX2PWM’s switching node is a low-side switch, which means that the LED is on when the (-) connector is switched to GND (low).
 Low-Side switch: low= on, high= off

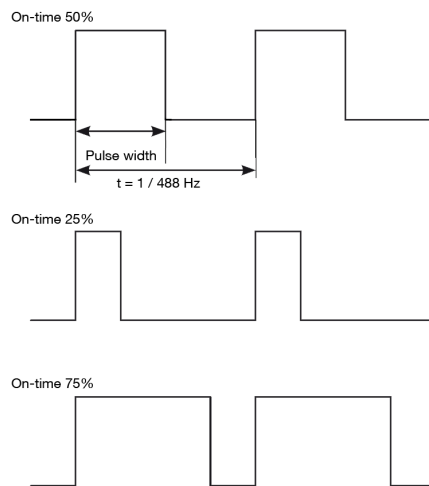

9 Dismounting



Before dismounting, appropriate measures must be taken to protect the respective components against damage caused by electrostatic discharge (ESD protection).

Disconnect all attached cables and dismount the e:cue DMX2PWM 3CH. The dismounting is completed.

10 Certifications



Intertek
4000805



Conforms to UL Std. 60950-1
Certified to CSA Std. C22.2 NO. 60950-1



11 Dimensions

All dimensions in mm

