



TRAXON

Media Tube® Go

INSTALLATION GUIDE

V1.1

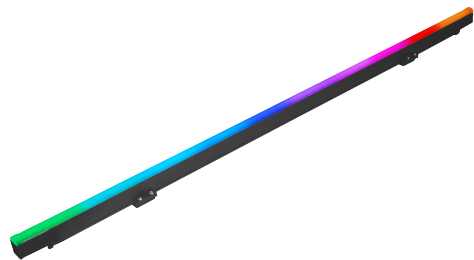
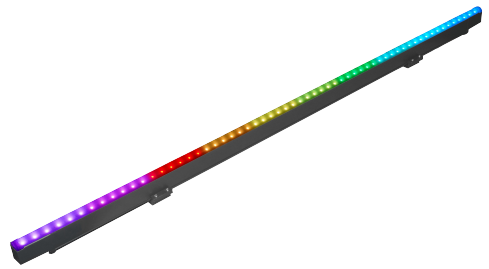

Cover:

Media Tube® Go RGBW

Media Tube® Go DW

CONTENT

1.	Safety and Operation	3
2.	Introduction	4
3.	Installation	8
4.	System Configuration	13
5.	Care and Maintenance	17
6.	Troubleshooting	18
7.	Technical Specification	19
8.	Warranty Statement	20

For your own safety and that of the product, please read this installation guide carefully before beginning setup and installation.

1. Safety and Operation

1. CAUTION - Unplug the power supply from the mains power before connecting any cables as this can damage the products.
2. CAUTION - Avoid looking directly into the LED light source at close range for your own safety.
3. Persons installing this product should make sure:
 - The installation complies with all applicable codes, state and local laws, ordinances, standards and safety regulations.
 - The installation environment is carefully studied and suitable surge protection measure(s) is taken.
 - He or she is qualified for the handling of electrical equipment.
4. Do not attempt to install or use the product until installation instructions and safety labels are fully understood. This product is designed for indoor and outdoor use.
5. Ensure product operates within the specified temperature range. (Refer to 7. TECHNICAL SPECIFICATION for more details.)
6. The Media Tube® Go does not contain any user-serviceable parts. Opening of the luminaire will void the warranty.
7. Do not use the product if any part of it, or the power cables are damaged.
8. Only use product for specified voltage, do not exceed. (Refer to 7. TECHNICAL SPECIFICATION for more details.)
9. Always maintain connection to ensure waterproofing.
10. If the product has been subjected to drastic temperature variances, for example, following transportation, do not connect the fixture until it has reached room temperature, as moisture condensation may cause electric shock and product damage.
11. When installing the products and system power supplies, please ensure they will not be exposed to moisture and extreme heat (and direct sunlight for outdoor products). Keep a clean operating environment for the fixtures and system power supplies.
12. Please study this Installation Guide thoroughly and check the latest Technical Specification Sheets available from the Traxon website www.traxon-ecue.com before setup.
13. Any non-compliance of the Installation Guide will void the Traxon warranty.

2. Introduction

2.1 General

Media Tube® Go Diffused	Length	Maximum number of pixels (PXL)
MEDIA TUBE GO DIFFUSED 2410 RGBW 20PXL	2410mm / 94.9"	20
MEDIA TUBE GO DIFFUSED 1210 RGBW 10PXL	1210mm / 47.6"	10
MEDIA TUBE GO DIFFUSED 370 RGBW 3PXL	370mm / 14.6"	3
MEDIA TUBE GO DIFFUSED 2410 DW 24PXL	2410mm / 94.9"	24
MEDIA TUBE GO DIFFUSED 1210 DW 12PXL	1210mm / 47.6"	12
MEDIA TUBE GO DIFFUSED 310 DW 3PXL	310mm / 12.2"	3

Media Tube® Go Clear	Length	Maximum number of pixels (PXL)
MEDIA TUBE GO CLEAR 2410 RGBW 20PXL	2410mm / 94.9"	20
MEDIA TUBE GO CLEAR 1210 RGBW 10PXL	1210mm / 47.6"	10
MEDIA TUBE GO CLEAR 370 RGBW 3PXL	370mm / 14.6"	3
MEDIA TUBE GO CLEAR 2410 DW 24PXL	2410mm / 94.9"	24
MEDIA TUBE GO CLEAR 1210 DW 12PXL	1210mm / 47.6"	12
MEDIA TUBE GO CLEAR 310 DW 3PXL	310mm / 12.2"	3

Media Tube® Go is a slim, direct view luminaire designed for all budgets to integrate into any wall, façade or media lighting application with tight installation requirements. Available in Clear View or Diffused View and 10 pixels per 1.2 meters / 2.5 pixels per foot, the Media Tube® Go ensures smooth effects along your facade, media application or bridge.

This product is intended for use in high-quality colored light applications.

Features:

- Available lengths: 370mm / 1ft (3PXL), 1210mm / 4ft (10PXL), 2410mm / 8ft (20PXL) for RGBW
- 310mm / 1ft (3PXL), 1210mm / 4ft (12PXL), 2410mm / 8ft (24PXL) for DW
- Diffused view and clear view
- Two color options: RGBW, DW (2200K - 6500K)
- DMX512
- Daisy Chain System with quick lock connectors
- Manual Addressing with TX Smart Addresser
- IK08 & ANSI 3G Vibration Rated
- IP67 Outdoor, suitable for coastal environments

2.2 Dimensions

FIG.1: Media Tube® Go RGBW

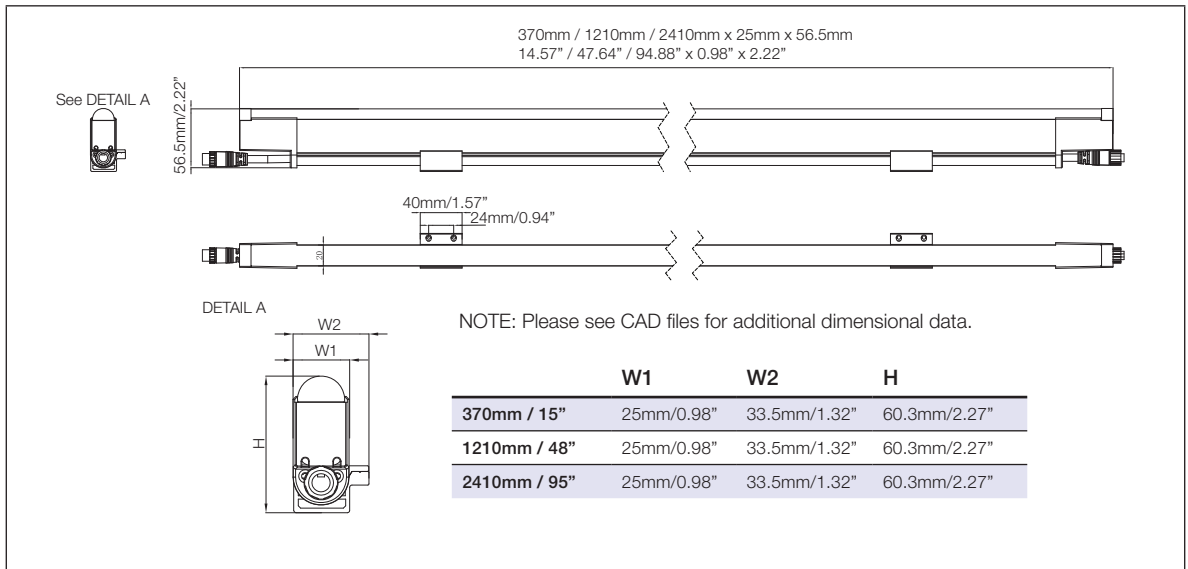

FIG.2: Media Tube® Go DW

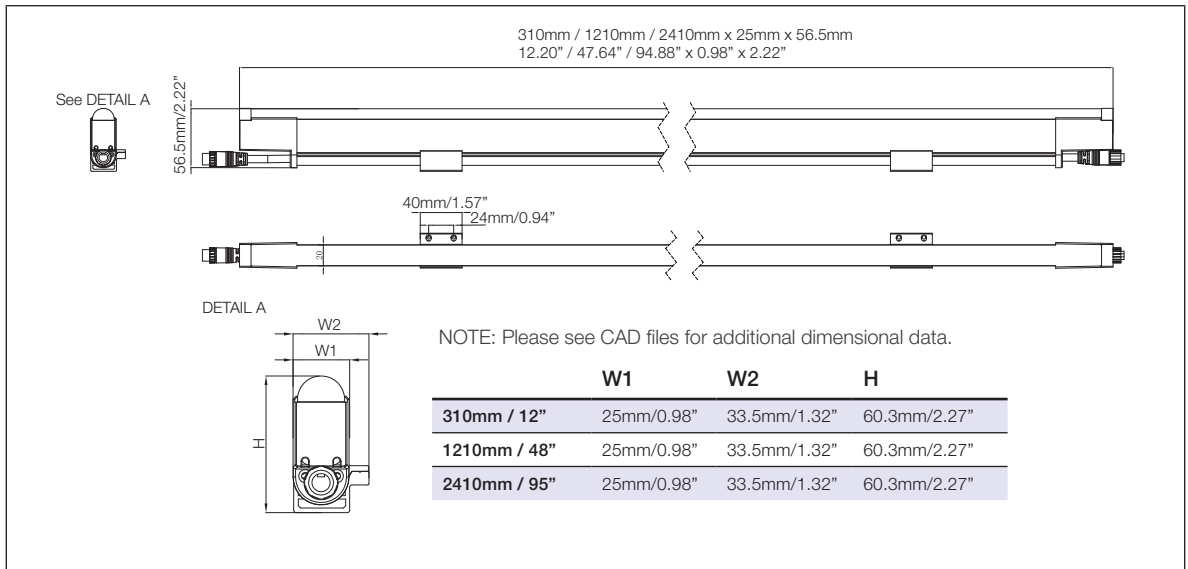
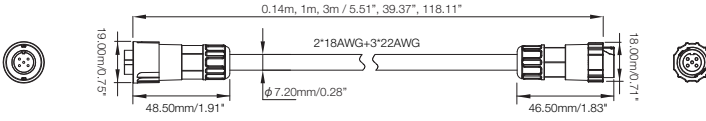

FIG.3: Media Tube® Go Accessories

5-pin interconnection cable (AM463780055/AM463790055/AM463800055)



Pin Color	Connection
Yellow-green	Addressing
Gray	DMX-
Black	DMX+
Blue	24V-
Brown	24V+

Starter cable (AM463750055/AM463760055)

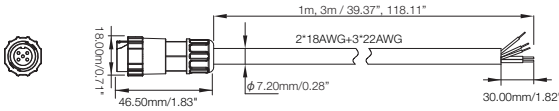

RJ45 Starter Cable (AM463820055)

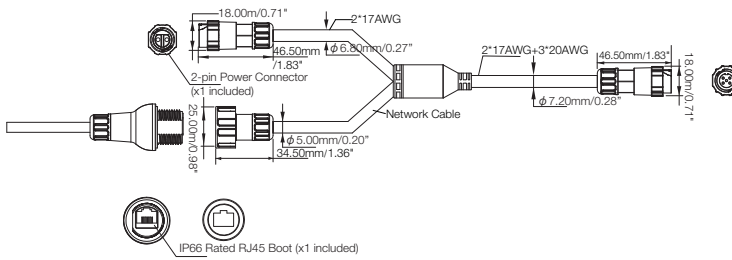

Pin Color	Connection
Yellow-green	Addressing
Gray	DMX-
Black	DMX+
Blue	24V-
Brown	24V+

Power injector cable (AM463810055)

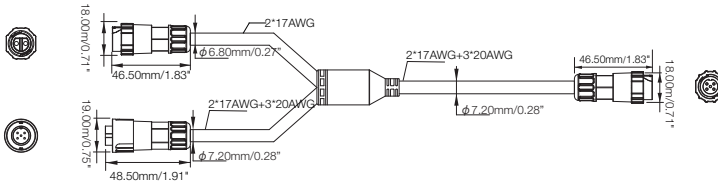

End Cap with 120Ω terminator (AM463770055)

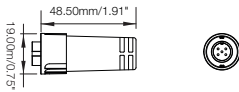

2.3 Packing Contents

FIG.4: Packing Contents

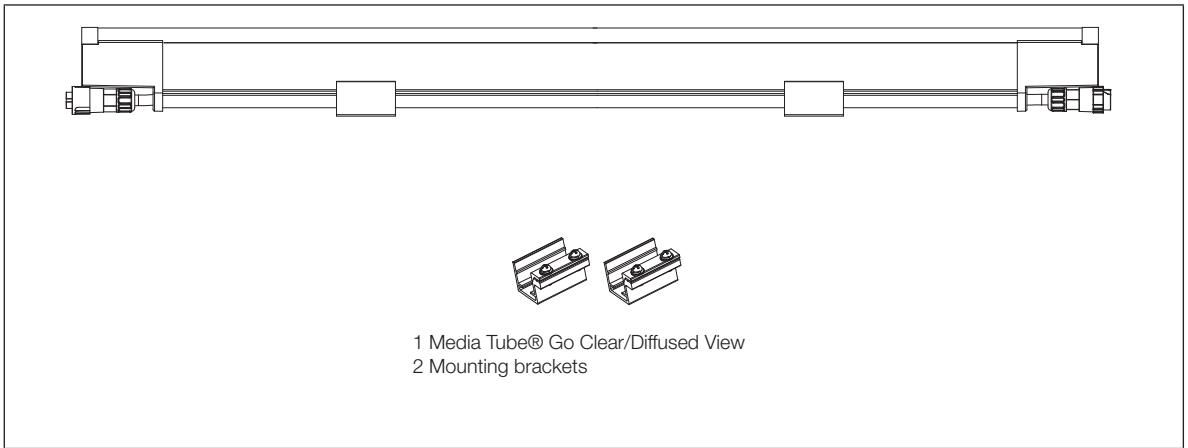

3. Installation

3.1 Points To Consider

Plan your installation before mounting the Media Tube® Go. The following should be considered for a successful installation.

- Weather conditions and ambient temperature of installation site.
- Appropriate cable lengths (cable gauges described in system diagram). Please consult your local Traxon office or authorized agent for necessary aid.
- The number of the Media Tube® Go and appropriate LED Engines.
- DMX512 to be used to control the Media Tube® Go.
- Distance between each Tube for thermal expansion and maintaining pixel pitch.
- Mounting distances.
- Proper surge protection.

FIG.5: Media Tube® Go Cable System

Starter Cable

From terminal block to first Media Tube® Go in chain

Starter cable (AM463750055/AM463760055)

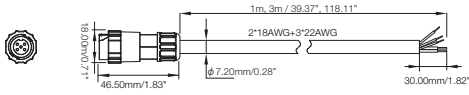

Interconnection Cable

From Media Tube® Go to another Media Tube® Go

5-pin interconnection cable (AM463780055/AM463790055/AM463800055)

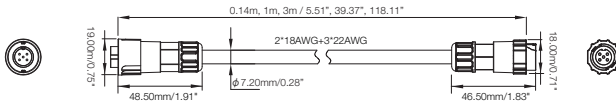

RJ45 Starter Cable

For RJ45 connection

RJ45 Starter Cable (AM463820055)

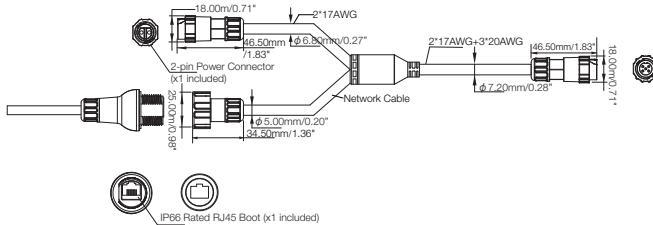

Power Injector Cable

For power connection

Power injector cable (AM463810055)

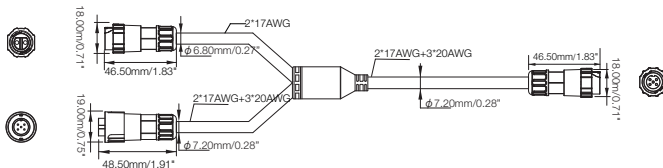

End cap includes DMX data terminator

End Cap with 120Ω terminator (AM463770055)

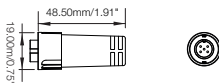

3.2 Pre-Installation Checks

3.2.1 Installation Checklist

1. Prepare cables and all necessary accessories (Waterproof Quick Lock End Caps etc).
2. Perform functional check of the Media Tube® Go. Take care not to damage cables/connectors during pre-installation checks.
3. Ensure all pre-installation checks laid out below have been followed.
4. Mount the Media Tube® Go on-site. If the installation is to be left uncompleted overnight, place all non-connected LED Engines and the Media Tube® Go in an indoor environment.
5. All units must be connected or utilize end caps to protect from water ingress.

Ensure all the Interconnection Cables, Media Tube® Go and LED Engines are initially stored in a dry area to guarantee the complete sealing of the system from water before installation.

3.2.2 Mounting Bracket

Mounting hardware (screws, lock washers and washers) are required for mounting the bracket to the surface. Mounting hardware by others. The mounting brackets can be moved along the extrusion to match installation requirements.

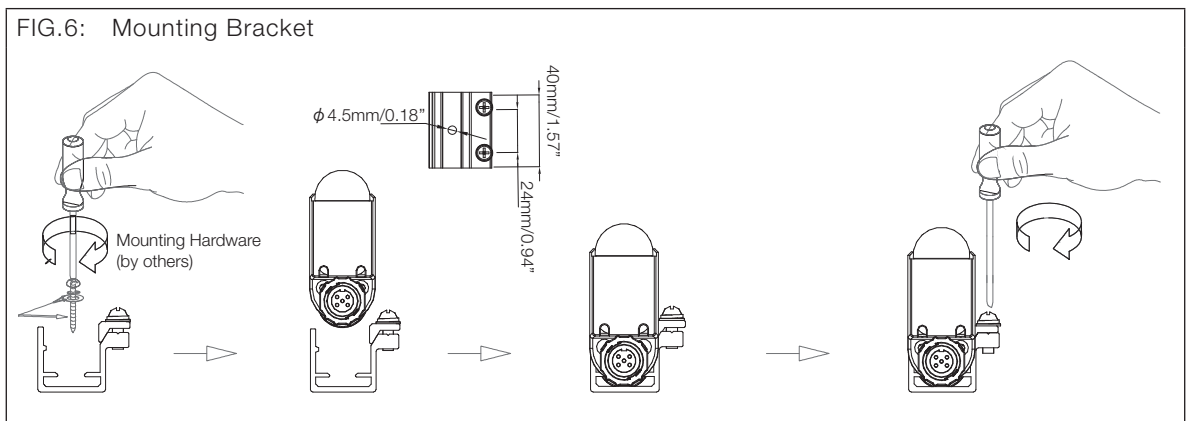

3.2.3 Installation Sequence

1. Measure the correct distances for brackets and install the Media Tube® Go fixtures.
2. Connect the Media Tube® Go in the daisy-chain manner outlined in the System Diagram to form large installations.
3. Perform functional check on all the Media Tube® Go and inspect cables and brackets for any damage. Check for any abnormalities with the control signal.
4. Report any functional defect found to your nearest Traxon Technologies office. DO NOT attempt to install the Media Tube® Go with functional defects on-site.

3.3 On-Site Installation



- DO NOT attempt installation in wet or severe weather conditions.
- DO NOT leave and expose any Media Tube® Go or LED Engines unconnected under wet/raining or snowing environment.
- IP failure induced by stressed/damaged cables during or after installation will not be under warranty by Traxon Technologies.
- ALWAYS keep the cables protected from sharp objects and ensure no damage is generated on the cable.

Failure to keep Media Tube® Go within the operating temperature range of -30°C to +55°C / -22°F to +131°F and storage temperature range of -40°C to +80°C / -40°F to +176°F will void the product's warranty.

3.3.1 On-Site Installation

1. Fix brackets to installation surface with anchor bolts or screws (by others).
2. The Media Tube® Go are interconnected using the IN and OUT cables/connectors on each end of the tube. Connectors will make an audible “click” when connected. Gently pull on the cables in opposites directions to ensure they are fully locked and do not come loose. The below diagram shows the Tube connections. Always remember to affix a Quick Lock Waterproof End Cap (sold separately) for the OUT connector of the final Tube in each daisy chain. See System Diagram for details.

FIG.7: Media Tube® Go Connections

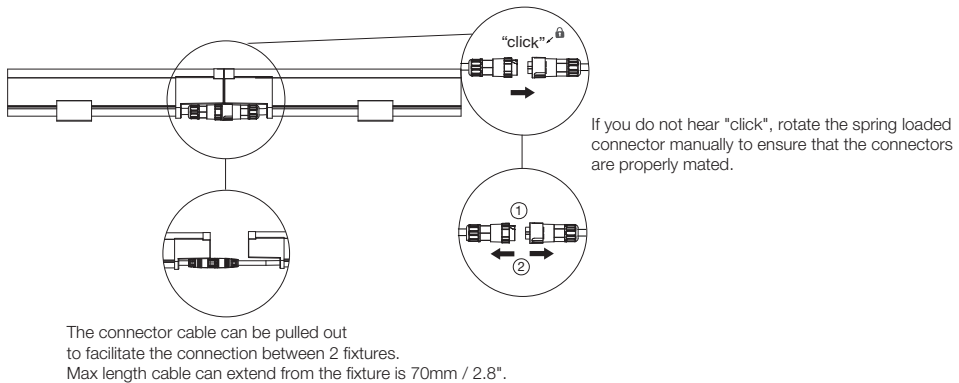

NOTE: Any water ingress incurred due to improper installation of cable connectors or Waterproof Quick Lock End Caps will not be covered under warranty by Traxon Technologies.

3. Be sure not to compress the IN/OUT cables.

NOTE: To keep LED pitch consistent and allow for thermal expansion, be sure to keep a minimum distance of 2mm (0.08") between consecutive Media Tube® Go (see below diagram).

FIG.8: Keep minimum distance between fixtures

To maintain consistent LED pitch and to allow for thermal expansion, a minimum of 2mm / 0.08" is required between luminaire's.

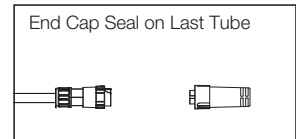

4. The first tube of the daisy-chain group has to be connected to the control system via Waterproof Junction Box (by others). Starter cables, Data and Power cables, and video fiber optic cables have to be installed through conduit.
5. Set up the control system indoors as detailed in the System Diagram and connect to the Media Tube® Go. Start each unit and verify correct function.

NOTE: For manual addressing setups, please refer to the configuration guide of TX Smart Addresser (CD.SA.0000100).

4. System Configuration

4.1 LED CONTROL

The LEDs on the Media Tube® Go are controlled by DMX512. For RGBW, each pixel on the Tube uses six RGB 3 in 1 LEDs and six white LEDs, for R, G, B and W channels. Pixel number 1 begins on the IN connector side, and it uses the first four channels. DW work in a similar way, but use less pixels per length.

	
RGBW	
Pixel n	Control Channel Number
R	$+4(n-1) + 1$
G	$+4(n-1) + 2$
B	$+4(n-1) + 3$
W	$+4(n-1) + 4$
Where: n is pixel number along the Tube. (Pixel 1 is located near the IN connector.)	

	
DW	
Pixel n	Control Channel Number
WW	$+ 2 (n-1) + 1$
CW	Tube start address +2n
Where: n is pixel number along the Tube. (Pixel 1 is located near the IN connector.)	

FIG.9: System Diagram (Starter Cable)



NOTE: The Address wire only needs to be connected during address configuration, it is not needed during operation. Wiring diagram shows only typical connections. Max. number of fixtures is based on minimal interconnection lengths. Actual number of fixtures is dependent on cable interconnections. Number of fixtures will reduce if longer cable lengths are used. Consult with your regional sales office to confirm maximums.

FIG.10: System Diagram (Injector Cable)

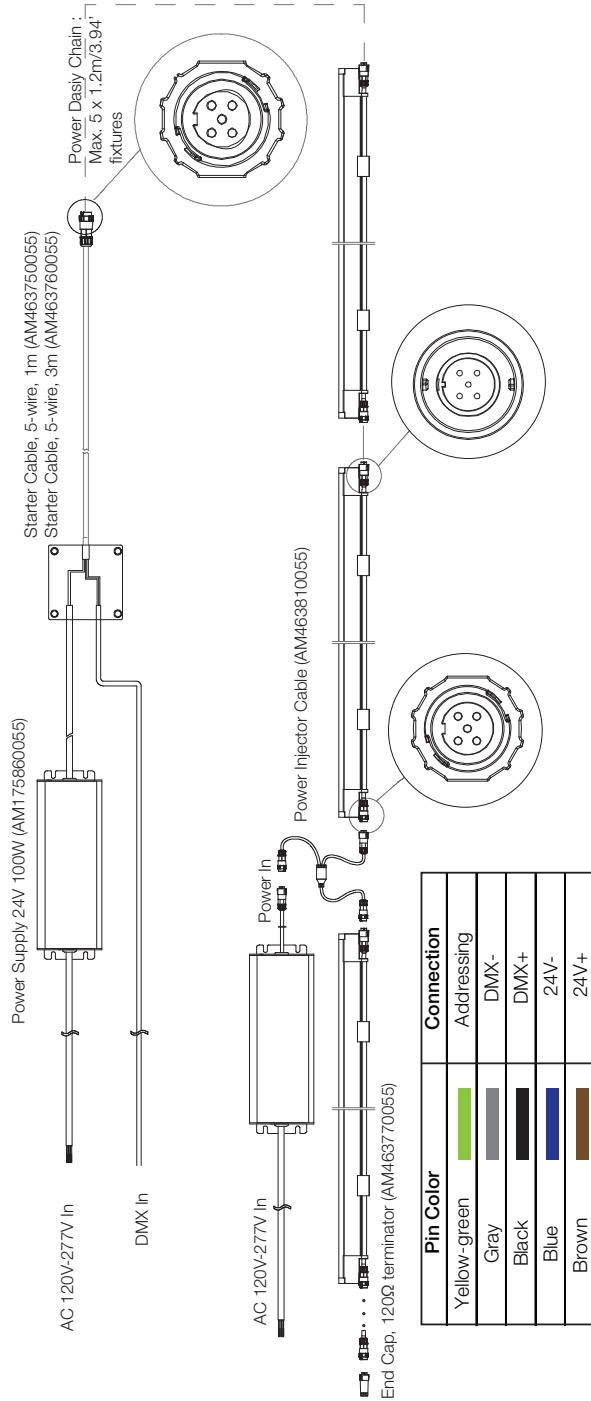
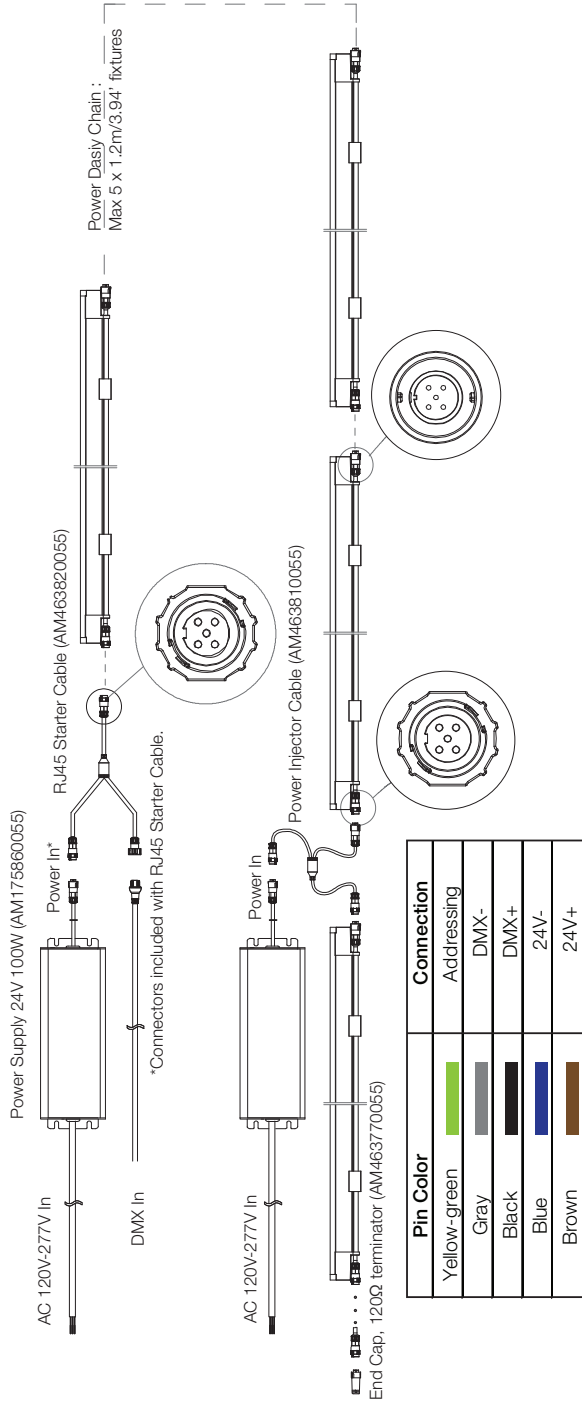

NOTE: The Address wire only needs to be connected during address configuration, it is not needed during operation. Wiring diagram shows only typical connections. Max. number of fixtures is based on minimal interconnection lengths. Actual number of fixtures is dependent on cable interconnections. Number of fixtures will reduce if longer cable lengths are used. Consult with your regional sales office to confirm maximums.

FIG.11: Orientation and Color Mixing

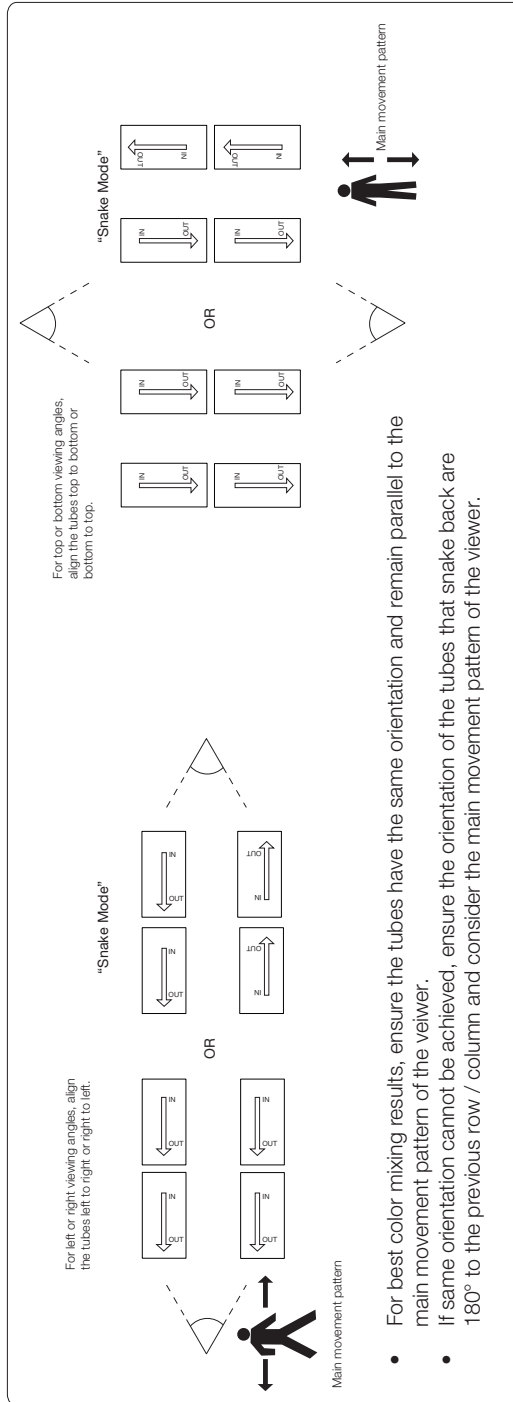

- For best color mixing results, ensure the tubes have the same orientation and remain parallel to the main movement pattern of the viewer.
- If same orientation cannot be achieved, ensure the orientation of the tubes that snake back are 180° to the previous row / column and consider the main movement pattern of the viewer.

5. Care and Maintenance

Traxon products are of superior design and quality and should be treated with care. The recommendations below will help fulfill any warranty obligations and gain good use and longevity from the products.

- Do not attempt or use the product(s) until you read and understand the installation instructions. Failure to adhere to these instructions could result in serious injury or property damage.
- Do not use product(s) if cables are damaged.
- Do not connect cables and connectors when wet or in wet area. Moisture on bare connectors can cause electric shock and damage to product(s).
- Do not use product(s) in extreme heat environment. Ensure there is sufficient airflow and use cool air circulation if required.
- Do not drop, knock, or shake product(s). Rough handling can damage the electronics and void the warranty.
- Do not use harsh chemicals, cleaning solvents, or strong detergents to clean products. Wipe with a damp cloth on housings and a dry cloth on electronics to remove dirt or dust.
- Do not attempt to service or repair the product(s) unless done by an authorized service personnel. Contact your local Traxon office or distributor for details.
- If the product is not working as specified, please contact your nearest authorized service center or Traxon Technologies office for assistance.

6. Troubleshooting



CAUTION: Ensure power supply is OFF when disconnecting / connecting cables.

Problem	Cause	Possible Solutions
Product does NOT light up after installation	Incorrect power connection	<ul style="list-style-type: none">– Check Mains Power– Check power supply leads and wire connections– Ensure output wires are connected with proper polarity– Check if LED Engine's secondary output is working as specified.
Shadowing	Light source covered	<ul style="list-style-type: none">– Check for cables, wires or unwanted debris covering LED light source
Modules are dim	Excess products connected	<ul style="list-style-type: none">– Ensure the power supplies are not overloaded due to an excess of products connected
Flickering	Incorrect power input/ Excess products connected	<ul style="list-style-type: none">– Ensure the input voltage is correct– Ensure the power supplies are not overloaded due to an excess of products connected

If problems persist or the product is not working as specified, please contact your nearest authorized service center or Traxon Technologies office for assistance.

7. Technical Specification

Media Tube® Go RGBW

	Clear			Diffused		
	370mm 15"	1210mm 48"	2410mm 95"	370mm 15"	1210mm 48"	2410mm 95"
Number of Pixel	3 pixels	10 pixels	20 pixels	3 pixels	10 pixels	20 pixels
Light Source:	18 RGBW 4-in-1	60 RGBW 4-in-1	120 RGBW 4-in-1	18 RGBW 4-in-1	60 RGBW 4-in-1	120 RGBW 4-in-1
Color Range:	RGBW (White CCT: 6500K standard)					
Beam Angle:	120°			110°x170°		
Power Input*:	24V DC					
Power Consumption (typ).:	4.5W / 15W / 30W					
Weight:	0.39kg / 0.86lb	0.88kg / 1.94lb	1.62kg / 3.57lb	0.39kg / 0.86lb	0.88kg / 1.94lb	1.62kg / 3.57lb
Operating Temperature:	-30°C to +55°C / -22°F to +131°F					
Storage Temperature:	-40°C to +80°C / -40°F to +176°F					

Media Tube® Go DW

	Clear			Diffused		
	370mm 15"	1210mm 48"	2410mm 95"	370mm 15"	1210mm 48"	2410mm 95"
Number of Pixel	3 pixels	12 pixels	24 pixels	3 pixels	12 pixels	24 pixels
Light Source:	21 2200K - 6500K	84 2200K - 6500K	168 2200K - 6500K	21 2200K - 6500K	84 2200K - 6500K	168 2200K - 6500K
Color Range:	DW (White CCT: 2200-6500K)					
Beam Angle:	120°			110°x170°		
Power Input*:	24V DC					
Power Consumption (typ).:	3.8W / 15W / 30W					
Weight:	0.39kg / 0.86lb	0.88kg / 1.94lb	1.62kg / 3.57lb	0.39kg / 0.86lb	0.88kg / 1.94lb	1.62kg / 3.57lb
Operating Temperature:	-30°C to +55°C / -22°F to +131°F					
Storage Temperature:	-40°C to +80°C / -40°F to +176°F					

As with all electronic devices, LED output degrades over time - a term called lumen depreciation. This also explains why it is nearly impossible to expect photometric performances of two LED products with different service life spans to be the same. The rate of LED degradation is a complex function of many factors such as operating efficiency, duration of continuous operation, and operating conditions (e.g. ambient temperature).

Because LEDs are semiconductor devices, their performances are subject to inherent variability commonly found in semiconductor industry. To improve consistency in performance across the same product, LED manufacturers "sort" LEDs into bins according to different preset parameters, such as forward driving voltage, illumination, etc. Whereas binning is a sorting function, it is not a correction process. Inherent variability in the manufacturing process always results in different binning distributions according to different production lots. Traxon uses automatically binned LEDs on its products, thereby minimizing output variations within the model range.

8. Warranty Statement

Traxon Technologies warrants its Products against material or workmanship defects for a period of five (5) years from date of purchase, provided that the purchased items are used under the conditions stated in this user manual.

Please refer www.traxon-ecue.com for all warranty terms and conditions.



TRAXON

TRAXON | ecue

Please check for the latest updates and changes on the Traxon website.
© 2023 TRAXON TECHNOLOGIES. ALL RIGHTS RESERVED.
www.traxon-ecue.com