

e:cue



TRAXON | e:cue
MEMBER OF PROSPERITY GROUP



AM466930031

e:cue SYMPL essential2 Node Information for Use

Read the Information for Use and the Safety Instructions carefully. Subject to modification without prior notice.

Typographical and other errors do not justify any claim for damages. Modification of the product is prohibited.

This manual is designed for electricians, system administrators, and product users.

All product names and trademarks mentioned in this manual are trademarks of their respective owners.

Except for internal use, relinquishment of the instructions to a third party, duplication in any type or form - also extracts - as well as exploitation and / or communication of the contents is not permitted.

Downloads and more information at:
www.ecue.com

Edition:

30.06.23 [EN_SYMPL_essential2_Node_Setup_v2p0]

Published by:

Traxon Technologies Europe GmbH
Karl-Schurz-Strasse 38
33100 Paderborn, Germany

©2023 Traxon Technologies Europe GmbH
All rights reserved

Traxon Technologies Europe GmbH
Sales Operations
Karl-Schurz-Str. 38
33100 Paderborn, Germany
+49 5251 54648-0
support@ecue.com

Table of Contents

1	Safety instructions	03
1.1	Symbols	03
1.2	General instructions	03
2	General device description	03
2.1	Delivery content	04
2.2	Optional accessories	04
2.3	Product specifications	04
2.4	Connectors and interfaces	05
2.5	User interface: LEDs	05
2.6	Identify button: Identification & Reset	06
3	General remarks	06
3.1	Transport	06
3.2	Unpacking	06
3.3	Warranty regulations	06
3.4	Maintenance and Repair	06
3.5	Disposal	07
3.6	Support	07
4	Installation	07
4.1	Installation conditions	07
4.2	Mounting process	08
4.3	Ethernet connection	08
4.4	DMX connection	08
4.5	Power supply	09
4.6	Grounding	09
5	Network configuration	10
5.1	Default network properties	10
5.2	Network configuration with SYMPHOLIGHT	10
5.3	Network configuration with the web interface	11
6	FastDMX	12
7	Test mode	12
7.1	Test mode via Test button	12
7.2	Test mode via Web interface	13
8	Firmware Update	13
9	Dismounting	14
10	Certifications	14
11	Dimensions	15
12	FAQ	15
12.1	About the SYMPL essential2 Node	15
12.2	Protocols	16
12.3	System	16
12.4	Power supply	16
12.5	Network	16
12.6	Update	17

1 Safety instructions

Please read the safety instructions, provided in a separate manual, carefully. Make sure that the environmental, mounting, and installation prerequisites are met. This manual should be kept at a safe place and in reach of the device.

1.1 Symbols



The exclamation mark warns about possible damage of the device itself, to connected devices, and to the user.



The information symbol gives general hints and informs about handling and procedures for use of the device.

1.2 General instructions



- Connect cables and data only when the device is powered down.
- When using a power supply unit, the device must be supplied by a separate power supply that is certified according to the local regulations (e.g. SELV, Class 2).



- If safety instructions are missing, please contact Traxon e:cue to receive a new copy.

2 General device description

e:cue SYMPL Nodes are a system of interfaces for e:cue SYMPHOLIGHT only. They provide various connection types like DMX512, DALI, digital inputs and outputs etc. SYMPL Nodes always operate in online mode, as a device interface for SYMPHOLIGHT. All interactions are initiated and controlled by SYMPHOLIGHT. Connections between servers and Nodes are always made with e:net via Ethernet.

The SYMPL essential2 Node is the dedicated output device for a high amount of controllable channels. It comes with 8 x DMX universes over screw terminal plugs.

The SYMPL essential2 Node is especially designed for the control of medium to large size DMX installations. Over Ethernet within SYMPHOLIGHT or the LAS, the SYMPL essential2 Node makes it possible to run up to 4096 (8 x 512) DMX512 channels (= 1360 (8 x 170) RGB Pixel) - or only within SYMPHOLIGHT up to 8192 (8 x 1024) FastDMX channels (= 2728 (8 x 341) RGB Pixel). In addition, the SYMPL essential2 Node provides Test modes for checking the installation.

The SYMPL essential2 Node is powered by an external power supply or via Power-over-Ethernet (PoE). It is easily mounted on standard 35 mm DIN rails, or via suspension holes in the base plate of the housing for mounting on walls or any vertical surfaces.



- To operate the SYMPL essential2 Node a SYMPHOLIGHT version 5.3 or higher is mandatory. Earlier versions do not support the SYMPL essential2 Nodes.
- Connections to the SYMPL essential2 Node are not hot-pluggable.

2.1 Delivery content

Delivery content for the e:cue SYMPL essential2 Node (AM466930031):

1. e:cue SYMPL essential2 Node
2. Safety instructions
3. Installation guide
4. 8 x 3-pin DMX terminal plug
5. 3-pin Power terminal plug

2.2 Optional accessories

- Power Supply 15W 24V DIN rail (AM1884100HA)
- SYMPL Switch (AM313830035)

2.3 Product specifications

Product number	AM466930031
Dimensions (W x H x D)	143 x 92 x 62 mm / 5.63 x 3.6 x 2.4 in (excl. fastening clip)
Weight	250 g / 0.55 lb
Power supply input	12 ... 24 V DC terminal plug (5.08 mm pitch) wire gauge: 0.2 - 3.3 mm ² reverse polarity protection or PoE IEEE 802.3af on RJ45
Power consumption	max. 3.5 W (incl. DMX termination)
Operating temperature	-30 ... 60 °C / -22 ... 140 °F
Storage temperature	-40 ... 70 °C / -40 ... 158 °F
Operating / storage humidity	0 ... 80% RH, non-condensing
Protection class	IP20
Electrical safety class	SELV
Housing	Self extinguishing blend PC/ABS, UL E140692
Mounting	on 35 mm DIN rail (EN 60715), or with key hole on any stable vertical surface
Certificates	CE, UKCA

Interface specifications

Output interfaces	8 x DMX / FastDMX short circuit protected surge protection isolated in pairs 3-pin terminal plug (3.5 mm pitch) wire gauge: 0.08 ... 1.31 mm ² FastDMX: luminaire for 500 kbit/s or with automatic speed detection required
Ethernet-Port	1 x e:net 10/100 Mbit/s, RJ45
User interfaces	LEDs for Ethernet activity, device status, DMX status, error; Identify button; Test button; web interface for configuration



2.4 Connectors and interfaces

View from top:

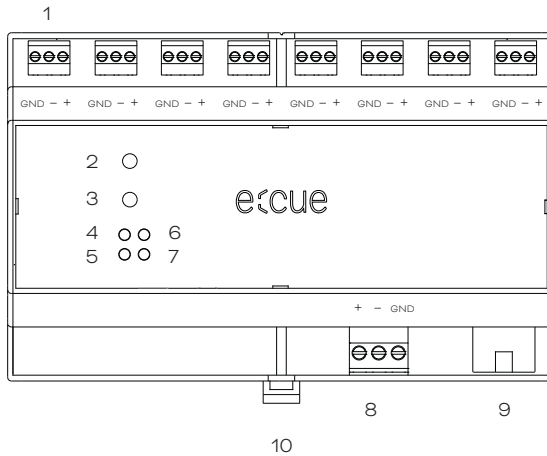

- | | | |
|----|---|---|
| 1 | DMX ports 1 ... 8
(GND, DMX -,
DMX + left to right) | „4.4 DMX connection“
auf Seite 08
„4.6 Grounding“ auf
Seite 09 |
| 2 | Test button | „7.1 Test mode via Test
button“ auf Seite
12 |
| 3 | Identify button | „2.6 Identify button:
Identification & Reset“
auf Seite 06 |
| 4 | LED e:net
(Ethernet) | „2.5 User interface:
LEDs“ auf Seite 05 |
| 5 | LED DMX | |
| 6 | LED Test / Error | |
| 7 | LED Status | |
| 8 | Power supply (V +,
V -, GND left to
right) | „4.5 Power supply“ auf
Seite 09
„4.6 Grounding“ auf
Seite 09 |
| 9 | e:net port
(Ethernet) | „4.3 Ethernet
connection“ auf Seite
08
„4.6 Grounding“ auf
Seite 09 |
| 10 | DIN rail handle | |

2.5 User interface: LEDs

The SYMPL essential2 Node has four LEDs on the front panel. The four LEDs show the basic states of the SYMPL essential2 Node.

LEDs

4	e:net	Off: no link available. On: link established. Blinking: e:net traffic.
5	DMX	DMX data traffic.
6	Test/Error	Off: no error detected. Short-short-long sequence: Test mode active. On: If constantly lights in red, an error occurred. This can be an internal error or malfunction of the device. Switch the device off and on. If the error persists, contact Traxon e:cue Service.
7	Status	On: If constantly on, the device is online. Server application is in operation. Blinking: If blinking in one second intervals, the device is offline, no connection to a SYMPHOLIGHT server or Core is available. If blinking more rapidly, the device is in bootloader mode.
6 + 7	Status + Test/Error	The Status and Test / Error LED blink simultaneously to identify the SYMPL Node (enabled “Identify Interface Mode” in SYMPHOLIGHT).

2.6 Identify button: Identification & Reset

The Identify button has three functions: to send an Identify message (A), to reset the Node (B), and to exit the error state (C)

(A) A short press during operation in online mode sends an Identify message to the server. This allows the Node of the installation to be associated with the indicated Node in SYMPHOLIGHT.

(B) The Identify button can also be used to reset the device to factory state or to stay in bootloader mode. With a reset you restore the password and other properties by using the Identify button. Please note that the device name and the offline content are not reset:

- Keep the Identify button pressed while powering up, Status and Test / Error LEDs light up at first. Bootloader mode is signaled by a fast blinking Status LED. Release the button now. The device stays in bootloader mode to download a new firmware.
To exit the bootloader mode, short press the Identify button again.
- Press the Identify button until Status and Test / Error LEDs blink alternating, then blink together. Releasing the button now resets the device to its factory settings. The password and other settings are reset to their default values. Please note that the Offline Content cannot be reset. To employ a reset Startup behavior, a restart of the device is required.
- Keeping the button pressed further on, the device proceeds to normal operation. No changes apply.

(C) Short press the Identify button if an error occurs and you want to exit the error mode. The device will switch back to normal activity if the cause of error is eliminated. The Node might reboot.

3 General remarks

3.1 Transport

Only transport the device in its original packaging. This protects the device from damage.

3.2 Unpacking

Only unpack the e:cue SYMPL essential2 Node at its installation location. To protect the device against condensation water, unpack it and wait until all moisture remaining in the device has evaporated.

Condensation can occur when the device is moved from a cold to a warm location. Keep the packaging for use in case of further transport. Inspect all parts for completeness regarding chapter „2.1 Delivery content“ on page 04. If there is apparent damage to the device or parts are missing from the delivery scope, please contact the Traxon e:cue support service.

3.3 Warranty regulations

Depending on the product, warranty regulations are of different duration. The warranty time is usually noted in the quote and in the order confirmation. See www.traxon-ecue.com/terms-and-conditions for details. Legal warranty regulations apply in any case.

3.4 Maintenance and Repair

This device requires no maintenance.



- Before dismounting, appropriate measures must be taken to protect the respective components against damage caused by electrostatic discharge (ESD protection).
- Do not try to repair the device. Return it to your Traxon e:cue distributor for replacement or repair.

3.5 Disposal



Batteries and technical appliances must not be disposed of with domestic waste, but should be handed in at the appropriate collection and disposal points.

The proper disposal of packing materials and of the device is the responsibility of the respective user and for his account; in all other matters, the retrieval obligation for packing materials and the device is subject to the statutory regulations.

3.6 Support

In case of technical problems or questions regarding installation and repair please contact:

Traxon Technologies Europe GmbH
 Customer Service
 Karl-Schurz-Str. 38
 33100 Paderborn, Germany
 +49 (5251) 54648-0
 support@ecue.com

4 Installation



- Connect cables and data only when the device is powered down.
- The device must be installed and operate in ambient temperature -30 ... 60 °C / -22 ... 140 °F and non-condensing.

The installation of the SYMPL essential2 Node consists of mounting the device, connections to power supply, to e:net, and to the DMX devices.

The sequence of cabling is not defined. Supply the device with power after all cabling is completed; it starts operating.

4.1 Installation conditions

Installation position	Terminals on top and bottom
Horizontal spacing	No spacing necessary
Minimum vertical rail grid spacing	115 mm (90 + 25 mm) (excluding conduit)
Recommended vertical rail grid spacing	160 mm (with 40 mm conduit)



4.2 Mounting process

The e:cue SYMPL essential2 Node is designed to mount onto a 35 mm DIN rail (EN 60715) in a vertical position.

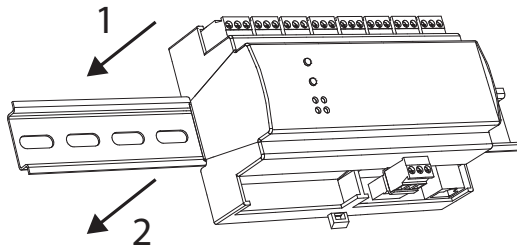

1. Clip the device to the rail from top.
2. Gentle pressure is then applied to the top front to snap it in place. The SYMPL essential2 Node has been mounted successfully.

You can also mount the e:cue SYMPL essential2 Node on any flat vertical surface. Use 3 to 3.5 mm screws for the hanger hole.



For mechanical stability, mounting on a rail is recommended.

4.3 Ethernet connection



- Never connect more than one SYMPL Node in factory state to a network. The identical IP addresses will conflict and disturb proper communication.
- Ethernet cable must be shielded.

The pin-assignment of the Ethernet port corresponds to RJ45 standards. You can use every common Ethernet component, like cable. Connect the SYMPL essential2 Node at the designated Ethernet interface with a patch cable (RJ45, CAT5).

4.4 DMX connection



- Ground the DMX cables.



- It is recommended to shield the DMX cables.

The SYMPL essential2 Node can control eight DMX universes with its eight DMX ports. Connect DMX devices to the SYMPL Node using 3-pin terminal plugs at the DMX interface of the SYMPL Node.

The appropriate pin assignment is defined as follows:

From left to right: GND, DMX -, DMX +

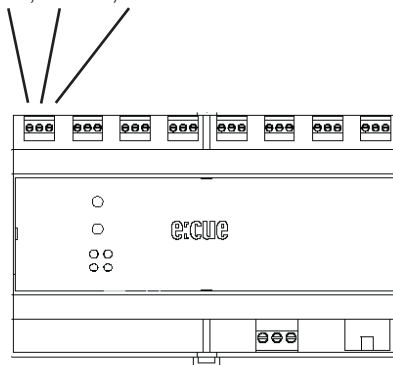

i It is recommended to use twisted pair cabling. 120 ohm or 100 ohm 1- or 2-twisted pair shielded cable are suitable for use with EIA-485 (120 ohm) and EIA-422 (100 ohm) devices.

4.5 Power supply

The e:cue SYMPL essential2 Node can be powered via Power-over-Ethernet (PoE) or by an external power supply (PSU).

PoE:

Connect an Ethernet connection from a power sourcing device.

External power supply:

Connect the SYMPL essential2 Node to a 24 V DC power supply unit that complies with the local regulations. Present power supply equates to the status “On” or running of the SYMPL essential2 Node.

To connect the device to a power supply unit, use the provided 3-pin terminal plug and lay the wires as stated on the front label.

The appropriate pin assignment is defined as follows:

From left to right: V +, V -, GND

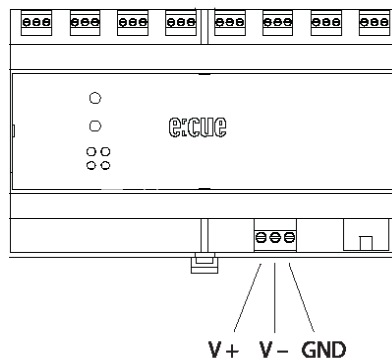

Turn the power on when all cables are connected to the SYMPL essential2 Node. The device starts operating. The device is in operation when the LED Status is flashing.



The SYMPL essential2 Node is not suited for powering over a DC power supply network. The device must be supplied by a separate power supply that is certified according to the local regulations (e.g. SELV, Class 2).

4.6 Grounding



- Connect the SYMPL essential2 Node's earth clamp to ground. Keep this cable as short as possible.
- Earth does not provide personal protection, only a leakage path for a possible overvoltage.

Use earth where applicable. Ground the DMX connection cables and the Ethernet cable. Ground each cable separately.

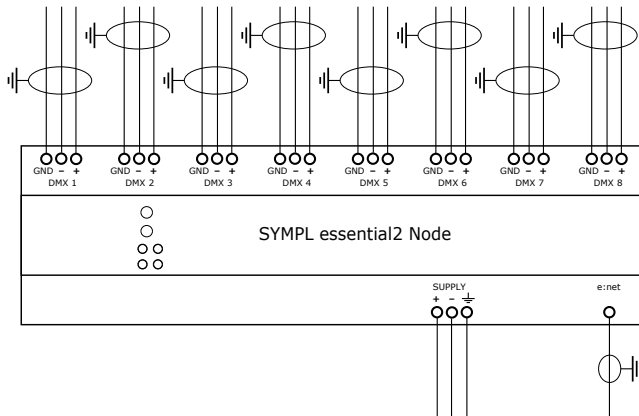

5 Network configuration

The configuration of the e:cue SYMPL essential2 Node is completely done via e:cue SYMPHOLIGHT. See the SYMPHOLIGHT System Manual for details on configuration, available at www.ecue.com.

The network properties of the device are preconfigured. The successful installation of the power supply is required for changing the network configuration. You can either adjust the network settings with SYMPHOLIGHT or using the web interface of the device. Via the web interface extended DMX settings are configurable.

5.1 Default network properties

The SYMPL essential2 Node has as factory setting the default IP address 192.168.123.1.
 Subnet mask: 255.255.255.0.
 DHCP is enabled by default.

Login credentials for the web interface of the SYMPL essential2 Node:

The default password is: **ecue**

To change the network configuration use either SYMPHOLIGHT or the web interface of the SYMPL essential2 Node:

5.2 Network configuration with SYMPHOLIGHT

1. Open the context menu of the SYMPL essential2 Node in the Setup tab of SYMPHOLIGHT by a right-click on the device.
2. Select "Configure Network":

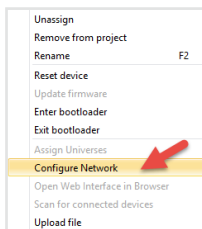

3. Define the IP address, the subnet mask and the DHCP settings to your needs:

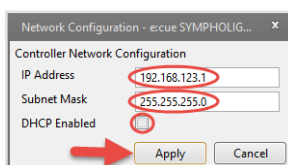

4. Click “Apply” to submit the changes.

The network configuration of the SYMPL essential2 Node is completed.

5.3 Network configuration with the web interface

1. Open a common web browser on a connected PC. Enter the SYMPL essential2 Node's IP address into the address bar:
e.g. http://192.168.123.1

The web interface of the SYMPL essential2 Node is displayed:

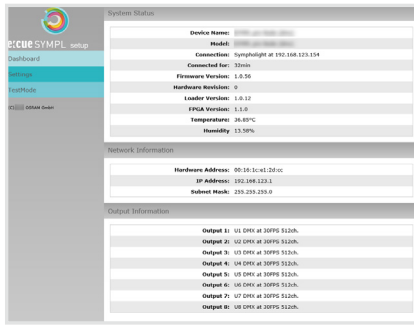

2. On the left side, select “Settings” and enter the default password **ecue**:

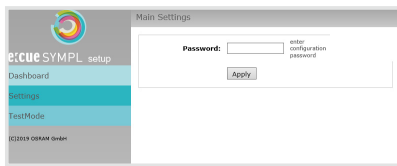

3. Click “Apply”. The Settings page is displayed:

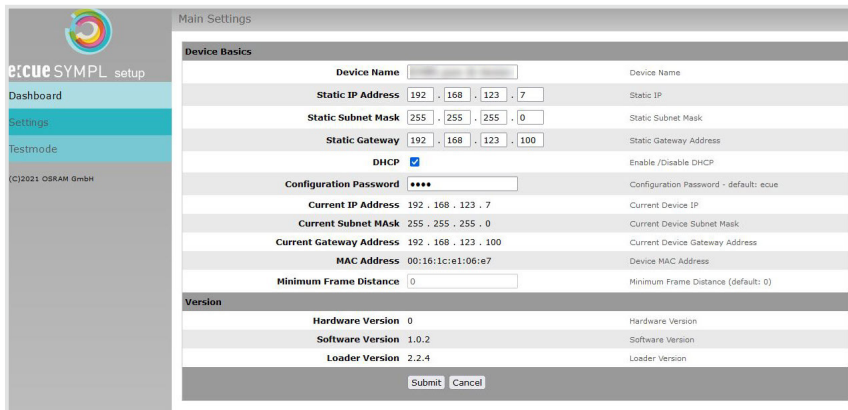

4. Define the network settings at “Device Basics” to your needs. You can also change the password for entry to the web interfaces of the SYMPL essential2 Node here.
5. Click “Submit” to apply the settings.

The network configuration of the SYMPL essential2 Node is completed.

- i** – The employment of a discrete network is recommended.
- Note down all employed and, if applicable, reserved IP addresses. Keep the information for future network configurations.
- You can change the login password to the SYMPL essential2 Node's configuration page and the device name of the SYMPL essential2 Node at "Settings" page. Do not forget the new password.

6 FastDMX

The SYMPL essential2 Node provides the option of FastDMX to output more DMX channels at undimished FPS than the default 512 channels. Each DMX port is separately configurable. The connected fixtures need to support automatic speed detection or 500 kbit/s.

To change the channel amount, bring the SYMPL essential2 Node into your SYMPHOLIGHT project. Then go to the Properties of an assigned universe. Change the Protocol type to "e:pix". The universe consists now of 1024 channels (with 500 kbit/s).

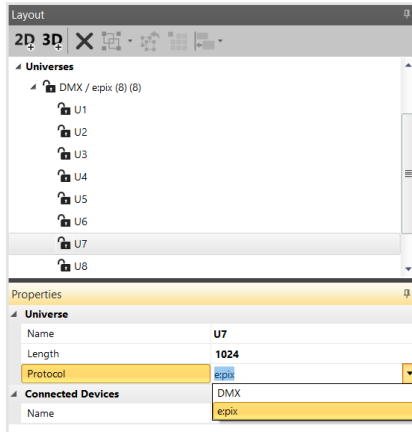

7 Test mode

The SYMPL essential2 Node provides a Test mode for the connected DMX devices. The Test mode is designed for DMX luminaires. There are two kinds: using the Test button and using the web interface of the SYMPL essential2 Node.

Please note that the Test mode overwrites all other DMX output like running shows, Startup Setting's or Offline Setting's output for the time of testing. A running show, the Startup and the Offline output respectively are reverted to after exiting the Test mode.

The Test mode is indicated by the blinking Test / Error LED.

7.1 Test mode via Test button

The Test button allows to test the connected DMX devices directly with the SYMPL essential2 Node.

- Keep the Test button pressed for about 5 seconds until the Test / Error LED flashes in the short-short-long sequence. Releasing the button now starts the Test mode at the first DMX port 1 with blinking lights of all channels.
- Short-press the Test button each time to switch between the following test patterns:
 - DMX port 2: All channels blink.
 - DMX port 3: All channels blink.
 - DMX port 4: All channels blink.
 - DMX port 5: All channels blink.

- DMX port 6: All channels blink.
- DMX port 7: All channels blink.
- DMX port 8: All channels blink.
- All ports: All channels blink.
- All ports: All channels to 100%.
- All ports: All channels to 0%.
- Repetition, beginning from the test pattern for DMX port 1.

- To exit the Test mode at any time, keep the Test button pressed for 5 seconds. The device proceeds to normal operation. The Test / Error LED is off. The last test pattern will not be exited by the device.

7.2 Test mode via Web interface

The web interface of the SYMPL essential2 Node provides four different test patterns and allows to change their properties.

To access the web interface, open a common web browser on a connected PC. Enter the SYMPL essential2 Node's IP address into the address bar:
e.g. <http://192.168.123.1>.

Open the Test mode page by selecting "TestMode" on the left side of the web interface of the SYMPL essential2 Node:

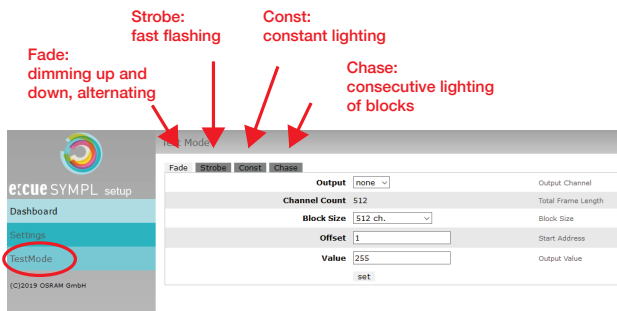

Click a button to choose a test pattern. Define the properties:

Property	Description
Output	DMX ports to run the test on.
Channel Count	Total frame length (0 - 1024).
Block Size	Block size in which to step through the frame length in channel count.
Offset	Start address of the first test loop (first channel = 1).
Value	Luminance of the test output (0 - 255).
Step Time	Delay between steps. Manual: Press the Test button to move the block. Define the first channel at "Start Address".

Click "set" to run the test and to apply changes in the test settings.

Exit the Test mode by leaving the Test mode page, e.g. go to "Dashboard", or by double-pressing the Identify button.

8 Firmware Update

To update the SYMPL essential2 Node, a connection of the SYMPL essential2 Node to SYMPHOLIGHT is required.

Updating with SYMPHOLIGHT

Use the usual update options in the Device Tree of the Setup tab in SYMPHOLIGHT: select "Update

firmware” in the context menu of the SYMPL essential2 Node or click the Update button  in the head toolbar.

9 Dismounting



Before dismounting, appropriate measures must be taken to protect the respective components against damage caused by electrostatic discharge (ESD protection).

Disconnect all attached cables. Dismount the e:cue SYMPL essential2 Node from the rail by pulling the black DIN rail handle and unhitching the SYMPL essential2 Node. The dismounting is completed.

10 Certifications



11 Dimensions

All dimensions in mm

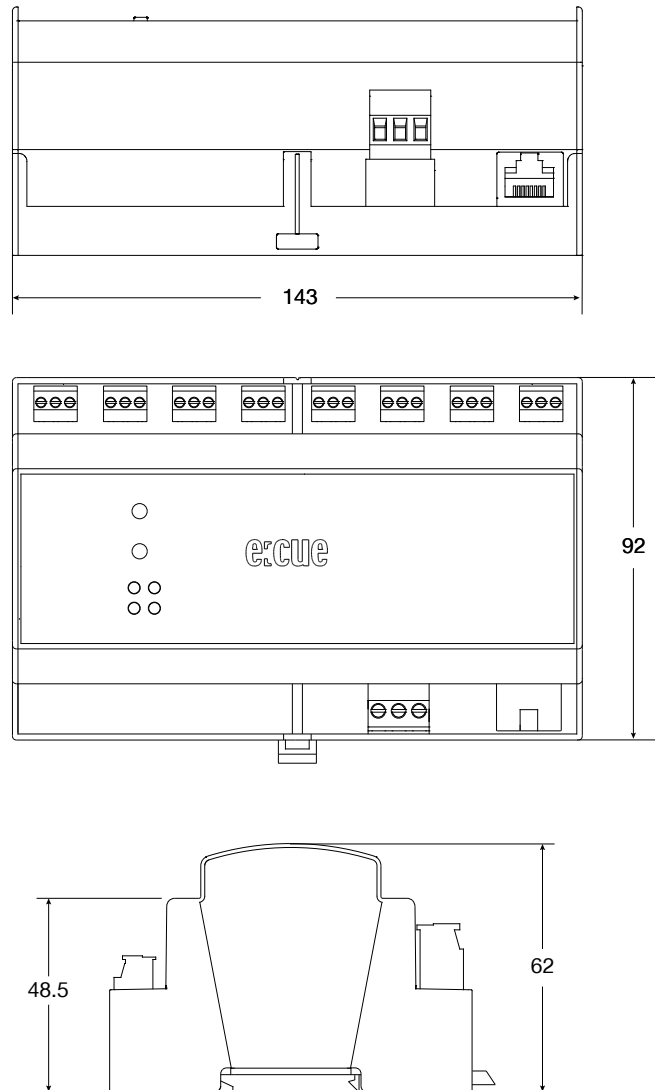

12 FAQ

12.1 About the SYMPL essential2 Node

Does the device support DMX?

Yes. The SYMPL essential2 Node supports DMX.

Does the device support RDM?

No. The SYMPL essential2 Node supports one-directional communication only.

What do the blinking LEDs on the device and their colors mean?

The LEDs indicate the basic states of the SYMPL essential2 Node. See „2.5 User interface: LEDs“ on page 05.

Can I test my installation?

Check whether your installation with its wiring and configuration is correct by using one of the two test options that come along with the SYMPL essential2 Node: the Test mode in the web interface or directly on

the device via the Test button. For the Test mode, see „7 Test mode“ on page 12, for the test using the Test button „2.6 Identify button: Identification & Reset“ on page 06.

Can I repair the device myself?

No. Do not try to repair the device. Return it to your Traxon e:cue distributor for replacement or repair.

What can I do if my device does not work anymore?

Please contact your supplier in case of malfunctioning.

Where can I get help or send feedback?

In case of technical problems or questions regarding installation and repair please contact the customer service (see „3.6 Support“ on page 07). Any other feedback is also more than welcome!

12.2 Protocols

Which output protocols are supported?

The SYMPL essential2 Node supports DMX512 and FastDMX.

How can I configure the DMX protocols?

Head to SYMPHOLIGHT. Here you can select the protocol type for each universe (see „6 FastDMX“ on page 12).

Can I create my own DMX protocols?

No. It is only possible to use the two provided DMX protocols.

How do I know which protocol is required?

This should be evident from the manufacturer's data sheet or manual. Alternatively, the dealer of the product will be able to provide information here.

12.3 System

Do I need a SYMPHOLIGHT license/ dongle?

Yes. To control the output, you need a SYMPHOLIGHT license.

Is it possible to use more than one SYMPL essential2 Node?

Yes. You can integrate multiple SYMPL essential2 Nodes in your installation. As part of the e:cue SYMPL family, you can also combine it with the whole SYMPL range of interfaces.

Can I use other controllers apart from the SYMPL essential2 Node to control fixtures?

Yes. To control the fixtures in the installation, you can use further control devices apart from the SYMPL essential2 Node.

12.4 Power supply

How can I supply power to the SYMPL essential2 Node?

You have two options: **a)** use an external power supply unit at the Power Supply input, or **b)** use PoE at the Ethernet connection. For more information see „4.5 Power supply“ on page 09.

What is the minimum voltage for powering the SYMPL essential2 Node?

The minimum voltage is 12 V DC.

Can I use the SYMPL essential2 Node to power the fixtures?

No, this is not possible. But you can use one power supply unit for both.

12.5 Network

How can I change the IP address?

To change the IP address, you can either use e:cue's SYMPHOLIGHT, see „5.2 Network configuration with



[SYMPHOLIGHT](#)“ on page 10. Or the web interface, see „[5.3 Network configuration with the web interface](#)“ on page 11.

The current IP address cannot be reached. What can I do?

Make sure your SYMPL essential2 Node is not in bootloader mode and try to reload the web interface. Then try to find it in SYMPHOLIGHT. Do you know its IP address? Then make sure you are in the same network as the Node. You do not know its IP address? Or you have DHCP enabled without a DHCP server in the network? Reset it. It's IP address is now by default 192.168.123.1.

Unable to open the web interface of the SYMPL essential2 Node?

Please ensure that the SYMPL essential2 Node and your computer are in the same network. Make sure that each device in the network has a unique IP address. With e:cue's SYMPHOLIGHT your Node will be found easily by pressing the Identify button and configured conveniently (see „[5.2 Network configuration with SYMPHOLIGHT](#)“ on page 10).

12.6 Update

Where can I find the latest firmware update?

You can find the latest firmware versions either on www.ecue.com. Or you will get a notification in SYMPHOLIGHT when an update is available. For more information see „[8 Firmware Update](#)“ on page 13.

