



TRAXON

Date: _____ Quantity: _____

Company: _____

Project: _____

ProPoint® Linear 2.0 SO RGBW



The ProPoint Linear 2.0 SO RGBW is an AC Line powered luminaire in a slim profile. The ProPoint Linear 2.0 SO RGBW is available in 8W (SO) or 12W (HO) per foot output, 4 beam options, standard & custom finishes which can meet the needs for most projects. The daisy chain topology is augmented with a separate Data Injector allowing single cable feed combining data and power to fixtures.



Product Specifications

Model	ProPoint Linear 2.0 SO RGBW 1'	ProPoint Linear 2.0 SO RGBW 4'
Light Source	4-in-1 LED cluster x 5	4-in-1 LED cluster x 20
Color Range	RGBW (White CCT: 4000K standard) Other White CCT and RGBA available ¹	
Beam Angle	15°, 25°, 35°, 50° x 30°, 105° x 105°	
Luminous Flux	422 lm @15°	1895 lm @15°
Efficacy	56 lm/W @15°	60 lm/W @15°
Lumen Maintenance	L70 @ 25° 81,000 hours	
Cover Lens	Tempered glass	
Housing	Die Cast Aluminum	
Adjustment Options	±90 tilt	
Dimensions (L x W x H)	300mm x 58mm x 90mm (12" x 2.3" x 3.6")	1200mm x 58mm x 90mm (48" x 2.3" x 3.6")
Weight	1.35 kg (3 lbs.)	3.6 kg (8 lbs.)
Regulatory Listing & Safety Approval	cETLus, FCC, RoHS, ASTM B117-16, ANSI 3G, IK08	
Operating Temperature	-30°C to +55°C (-22°F to +131°F)	
Storage Temperature	-40°C to +80°C (-40°F to +176°F)	
Minimum Starting Temperature	-20°C (-4°F)	
Environment	IP66 Outdoor, suitable for coastal environments	
Humidity	85%, non-condensing	

Electrical Specifications

Input Voltage ²	100-277Vac 50/60Hz	
Power Consumption	8W	32W
Power Factor	≥ 0.9	

System Specifications

Power	AC line
Control	DMX512, RDM Enabled
Power Supply	Integrated

1. No MOQ required. Please consult regional sales office for pricing and lead time.
2. Auto-switching. Single phase (line, neutral and ground).

LED CHARACTERISTICS Because LEDs are semiconductor devices, their performances are subject to inherent variability commonly found in semiconductor industry. To improve consistency in performance across the same product, LED manufacturers "sort" LEDs into bins according to different preset parameters, such as forward driving voltage, illumination, etc. Whereas binning is a sorting function, it is not a correction process. Inherent variability in the manufacturing process results always in different binning distributions according to different production lots. Traxon uses automatically binned LEDs on its products, thereby minimizing output variations within the model range.

As with all electronic devices, LED output degrades over time – a term called lumen depreciation. This also explains why it is nearly impossible to expect photometric performances of two LED products with different service life spans to be the same. The rate of LED degrade is a complicate function of many factors such as operating efficiency, duration of continuous operation, and more significantly, environmental conditions (ambient temperature for example). If allowed working under optimal operating temperature range and with good ventilation, LED devices enjoy long service lives over conventional light sources. When using/installing LED devices, care should be taken to ensure that the devices will operate within the operating conditions specified in respective product literature.

This product contains a light source of energy efficiency class G to Regulation (EU) No 2019/2015. Lumen measurement complies with LM-79-08 standard. Lumen maintenance is calculated based on LM-80 compliant measurement.



www.traxon-ecue.com

©2023 TRAXON TECHNOLOGIES - AN OSRAM BUSINESS. ALL RIGHTS RESERVED. TRAXON™, TX CONNECT®, ARE TRADEMARKS OF TRAXON TECHNOLOGIES. U.S. PATENTS, E.U. PATENTS, JAPAN PATENTS, OTHER PATENTS PENDING. SPECIFICATIONS ARE SUBJECT TO CHANGE WITHOUT NOTICE.



TRAXON

ProPoint® Linear 2.0 SO RGBW

Dimensions

ProPoint™ Linear 2.0 1'

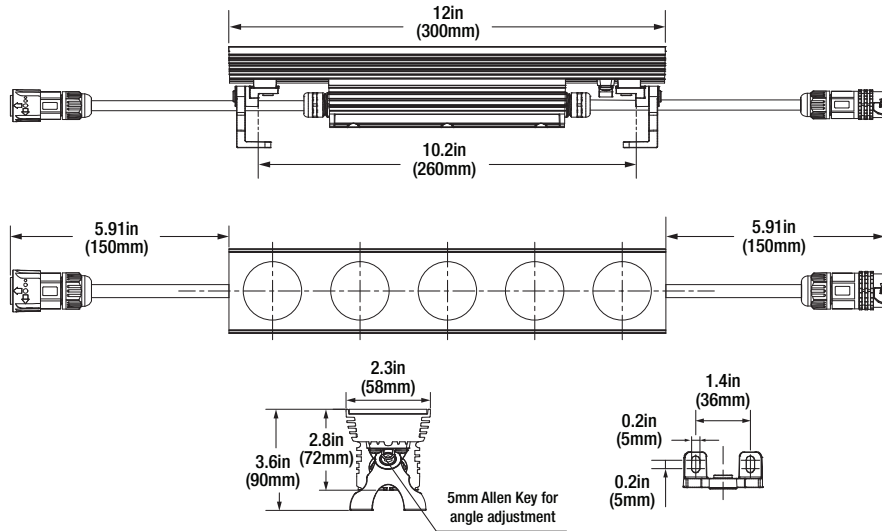

ProPoint Linear 2.0 4'

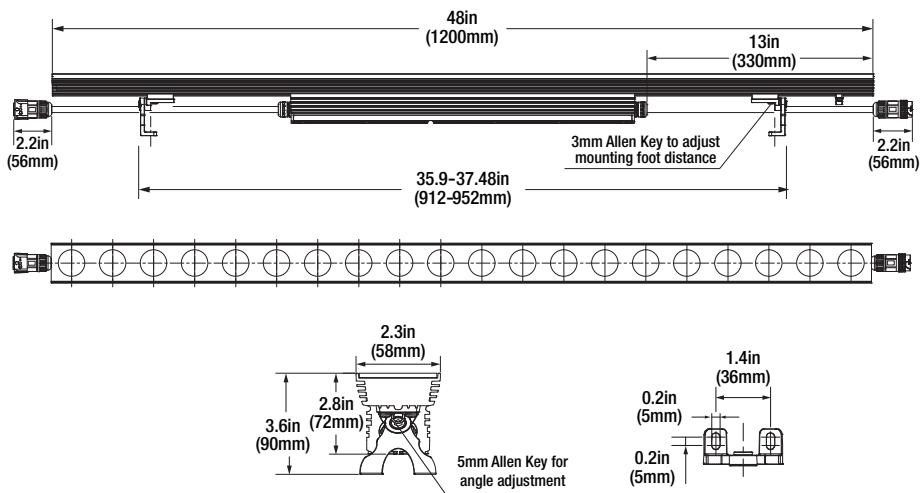



TRAXON

ProPoint® Linear 2.0 SO RGBW

System Diagram

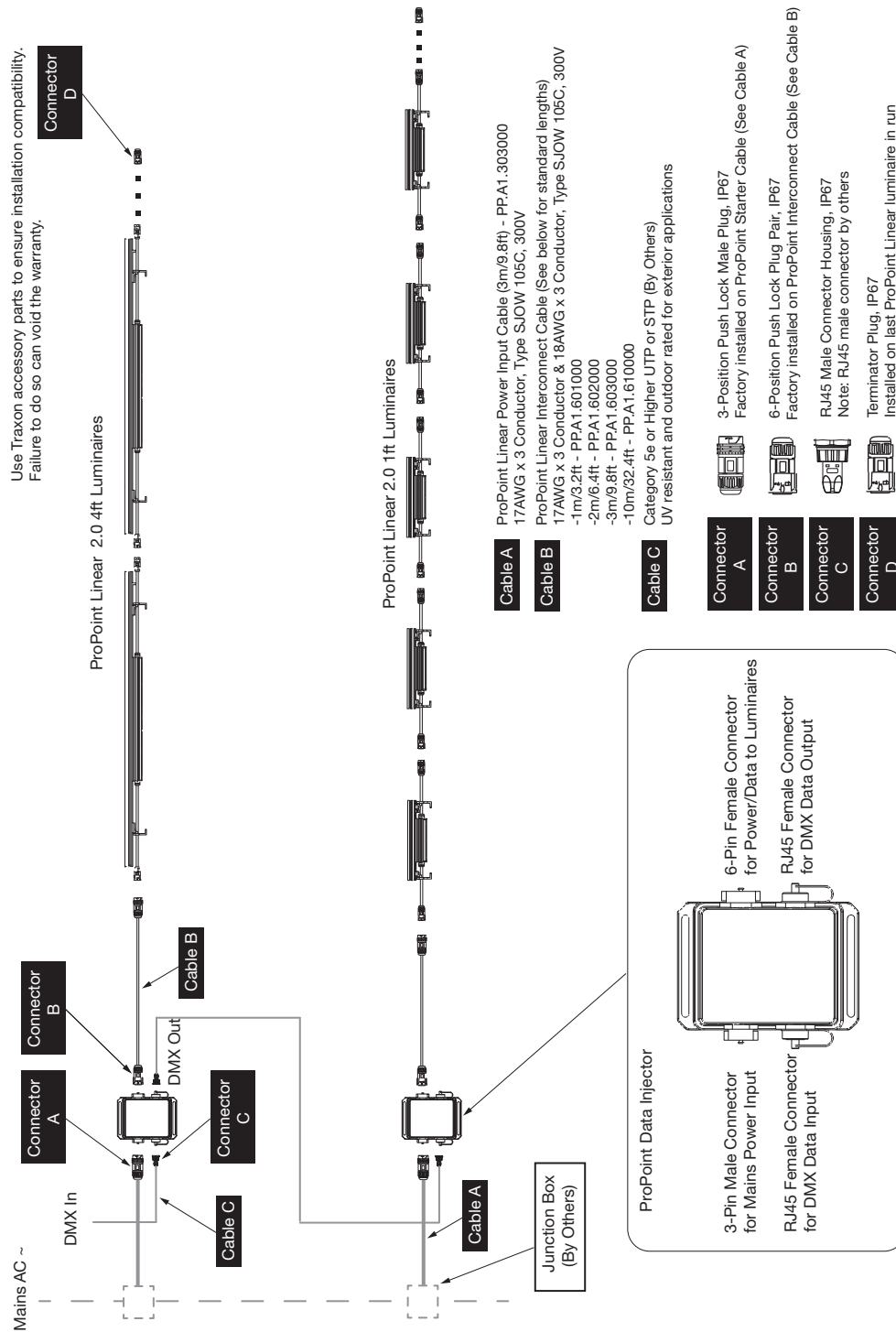

www.traxon-ecue.com

©2023 TRAXON TECHNOLOGIES - AN OSRAM BUSINESS. ALL RIGHTS RESERVED. TRAXON™, TX CONNECT®, ARE TRADEMARKS OF TRAXON TECHNOLOGIES. U.S. PATENTS, E.U. PATENTS, JAPAN PATENTS, OTHER PATENTS PENDING. SPECIFICATIONS ARE SUBJECT TO CHANGE WITHOUT NOTICE.



TRAXON

ProPoint® Linear 2.0 SO RGBW

Ordering

Fixtures Model Number

PP	.	XX	.	9	4	4	4	X	X
ProPoint		Linear SO		Control	Color	CCT	Approbation	Optic	Finish
		L5 - 4' 32W		9: DMX	4: RGBW	4: 4000K	4: cETLus	2: 15°	1: Gray
		L8 - 1' 8W						3: 25°	2: Black
								4: 35°	3: White
								5: 50° x 30°	
								6: 105° x 105°	

Desired Model Number:

PP	.	XX	.	9	4	4	4		0
----	---	----	---	---	---	---	---	--	---

Fixtures

Model No.	Description	Item Code
PP.L8.944421	ProPoint Linear SO (8W) 1' RGBW 15°	AM284280055
PP.L8.944431	ProPoint Linear SO (8W) 1' RGBW 25°	
PP.L8.944441	ProPoint Linear SO (8W) 1' RGBW 35°	AS000120055
PP.L8.944451	ProPoint Linear SO (8W) 1' RGBW 50°x30°	
PP.L5.944421	ProPoint Linear SO (32W) 4' RGBW 15°	AM284290055
PP.L5.944431	ProPoint Linear SO (32W) 4' RGBW 25°	
PP.L5.944441	ProPoint Linear SO (32W) 4' RGBW 35°	AS000130055
PP.L5.944451	ProPoint Linear SO (32W) 4' RGBW 50°x30°	
PP.L8.944422	ProPoint Linear SO (8W) 1' RGBW 15° BL	
PP.L8.944432	ProPoint Linear SO (8W) 1' RGBW 25° BL	
PP.L8.944442	ProPoint Linear SO (8W) 1' RGBW 35° BL	
PP.L8.944452	ProPoint Linear SO (8W) 1' RGBW 50°x30° BL	
PP.L5.944422	ProPoint Linear SO (32W) 4' RGBW 15° BL	
PP.L5.944432	ProPoint Linear SO (32W) 4' RGBW 25° BL	
PP.L5.944442	ProPoint Linear SO (32W) 4' RGBW 35° BL	
PP.L5.944452	ProPoint Linear SO (32W) 4' RGBW 50°x30° BL	
PP.L8.944423	ProPoint Linear SO (8W) 1' RGBW 15° WT	
PP.L8.944433	ProPoint Linear SO (8W) 1' RGBW 25° WT	
PP.L8.944443	ProPoint Linear SO (8W) 1' RGBW 35° WT	
PP.L8.944453	ProPoint Linear SO (8W) 1' RGBW 50°x30° WT	
PP.L5.944423	ProPoint Linear SO (32W) 4' RGBW 15° WT	
PP.L5.944433	ProPoint Linear SO (32W) 4' RGBW 25° WT	
PP.L5.944443	ProPoint Linear SO (32W) 4' RGBW 35° WT	
PP.L5.944453	ProPoint Linear SO (32W) 4' RGBW 50°x30° WT	



TRAXON

www.traxon-ecue.com

©2023 TRAXON TECHNOLOGIES - AN OSRAM BUSINESS. ALL RIGHTS RESERVED. TRAXON™, TX CONNECT®, ARE TRADEMARKS OF TRAXON TECHNOLOGIES. U.S. PATENTS, E.U. PATENTS, JAPAN PATENTS, OTHER PATENTS PENDING. SPECIFICATIONS ARE SUBJECT TO CHANGE WITHOUT NOTICE.



TRAXON

ProPoint® Linear 2.0 SO RGBW

Ordering

Accessories

Model No.	Description	Item Code
PP.AC.100001	ProPoint Data Injector Box (cETLus/CE)	AM280370055
PP.AC.100002	ProPoint Data Injector Box (cETLus/CE) BL	
PP.AC.100003	ProPoint Data Injector Box (cETLus/CE) WT	
PP.AC.600000	ProPoint Linear End Cap w/ Termination Resistor	AM280380055
PP.AC.400000	ProPoint RJ45 Field Install Connectors (pair)	AM280400055
PP.A1.303000	3m Power Input Cable (cETLus)	AM280360055
PP.A1.601000	1m ProPoint Linear Power/Data Int Cable (cETLus)	AM280310055
PP.A1.602000	2m ProPoint Linear Power/Data Int Cable (cETLus)	AM280330055
PP.A1.603000	3m ProPoint Linear Power/Data Int Cable (cETLus)	AM280340055
PP.A1.610000	10m ProPoint Linear Power/Data Int Cable (cETLus)	AM280350055
PP.LA.200011	Asymmetric Louver 1'	
PP.LA.200012	Asymmetric Louver 1' BL	
PP.LA.200013	Asymmetric Louver 1' WT	
PP.LA.200041	Asymmetric Louver 4'	
PP.LA.200042	Asymmetric Louver 4' BL	
PP.LA.200043	Asymmetric Louver 4' WT	
PP.LA.100001	Wall Mount Arm	
PP.LA.100002	Wall Mount Arm BL	
PP.LA.100003	Wall Mount Arm WT	
PP.AK.000003	ProPoint 3mm Allen Key	
PP.AK.000005	ProPoint 5mm Allen Key	