

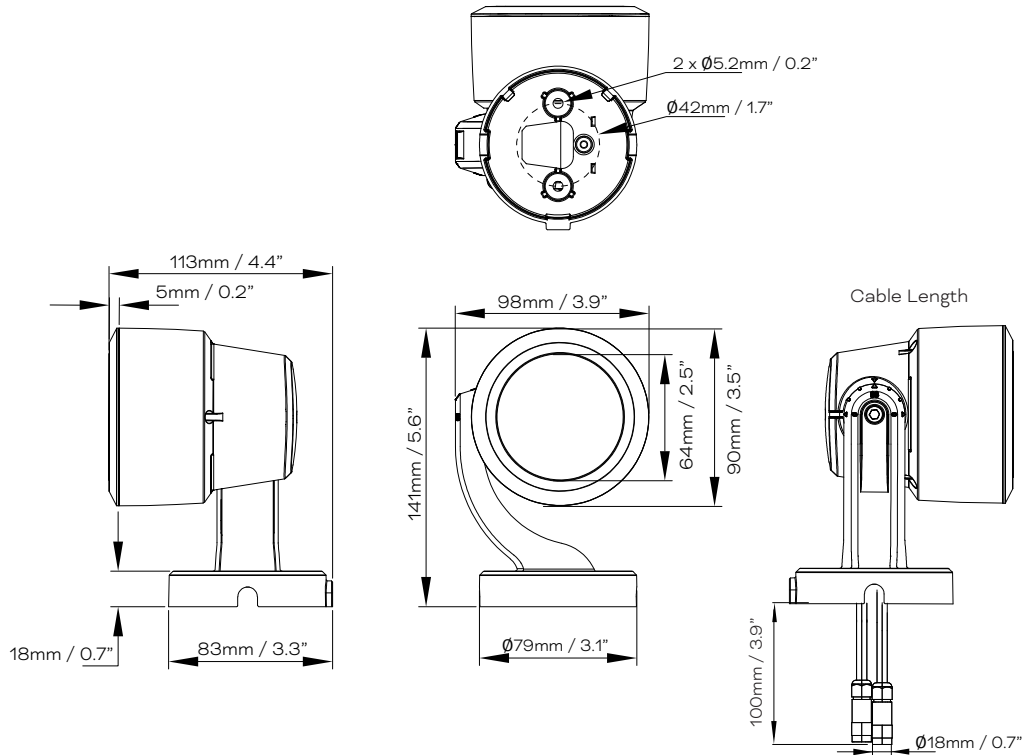

## Washer Pro Mounting Guide

### Dimensions (Nano)



### Dimensions (Micro)

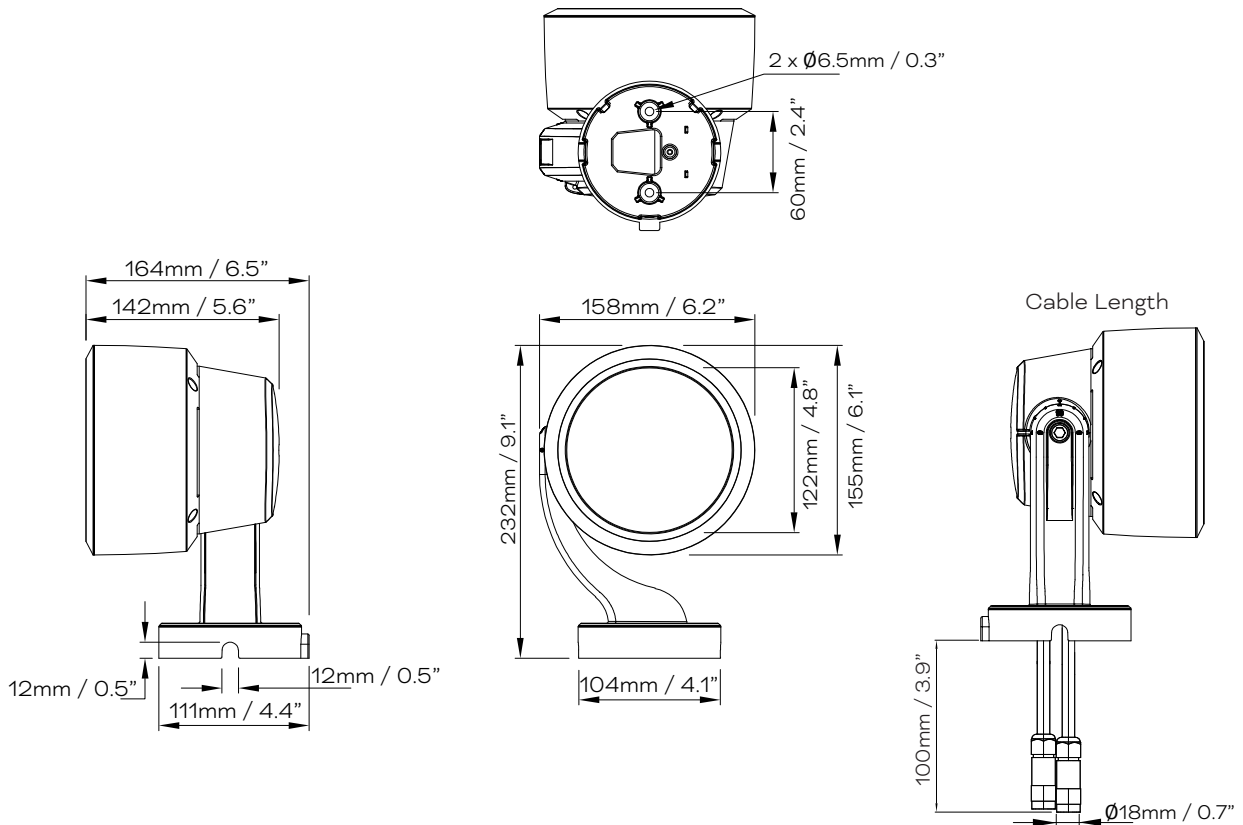



## Dimensions (Mini)

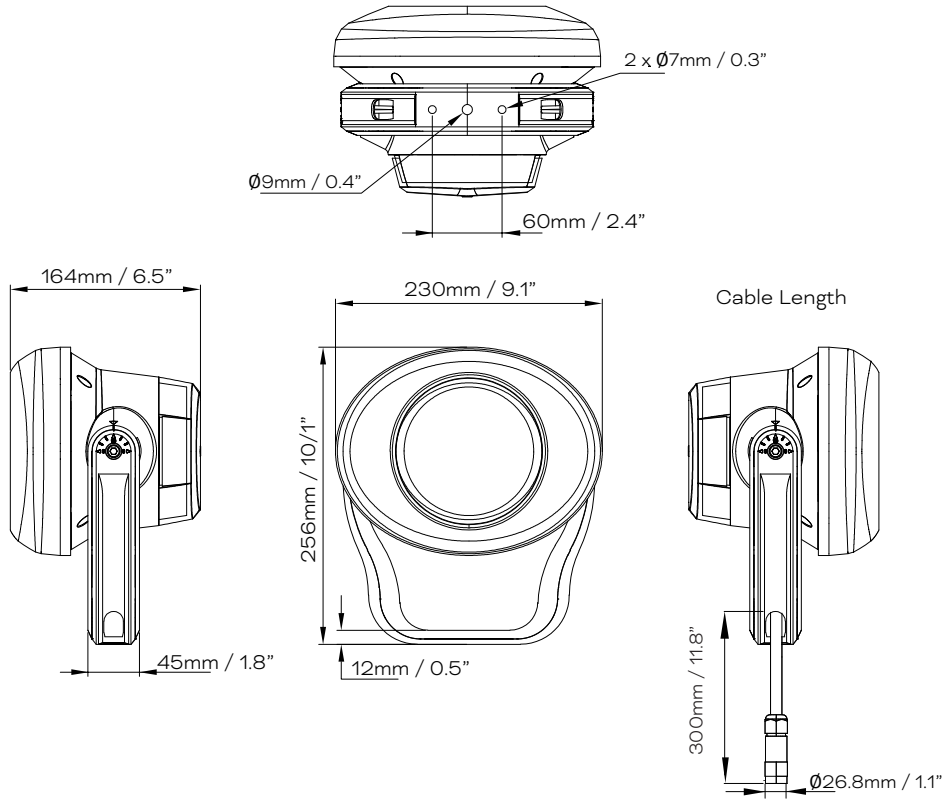

## Dimensions (Midi)

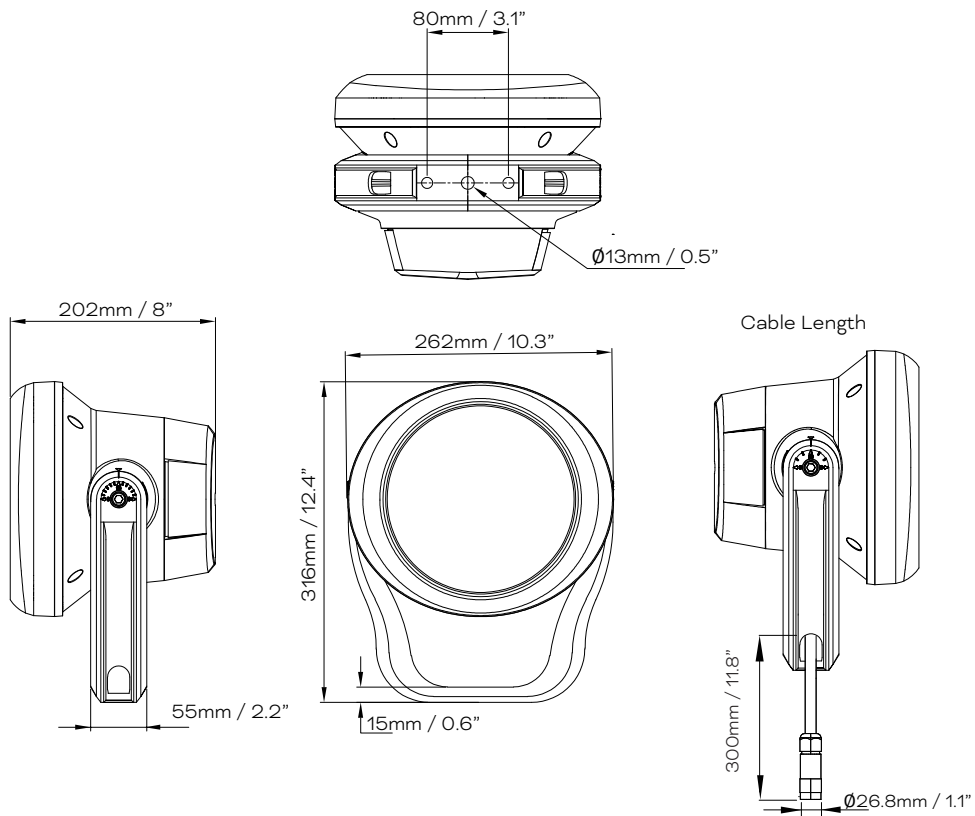



## Dimensions (Maxi)

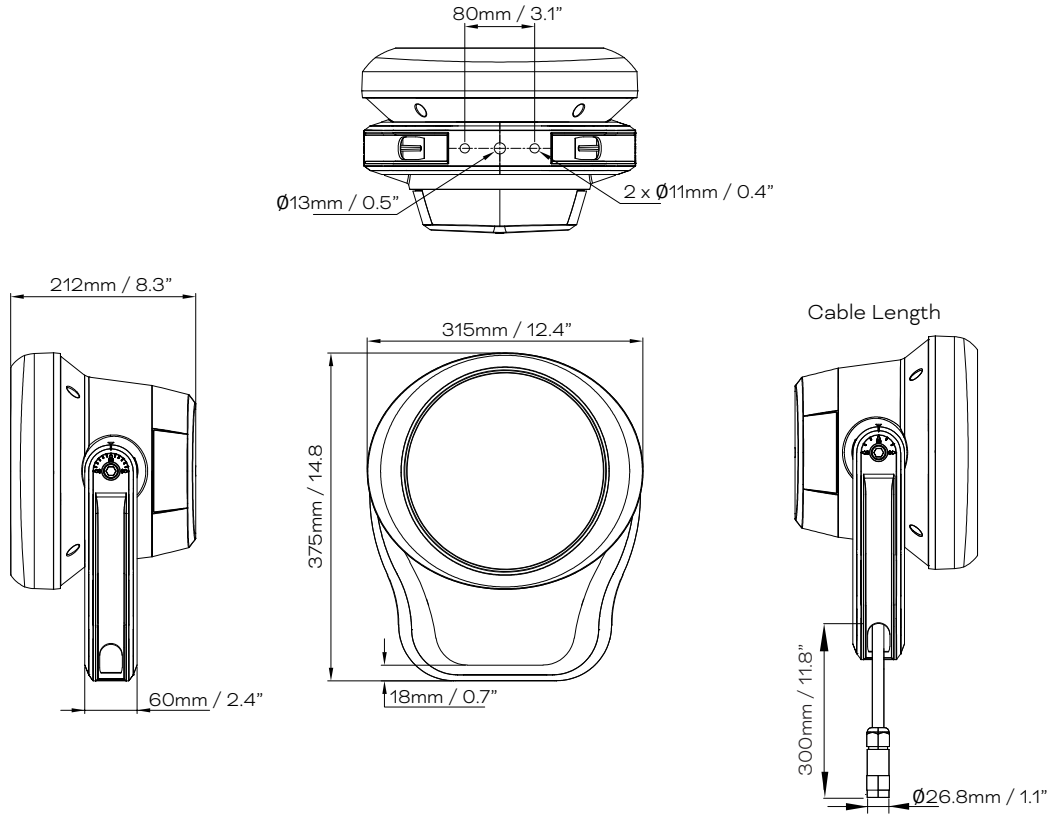

## Mounting (Nano)

### Install expansion screws on the fixed surface

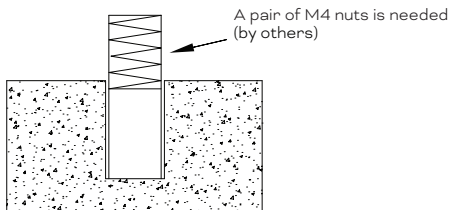

The size of the bracket mounting holes determines the size of the holes to be punched.

### Fix the bracket

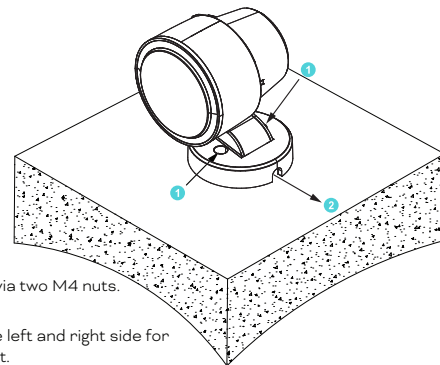

- 1 Fix bracket via two M4 nuts. (by others)
- 2 Holes on the left and right side for cable in / out.

### Adjust desired angles

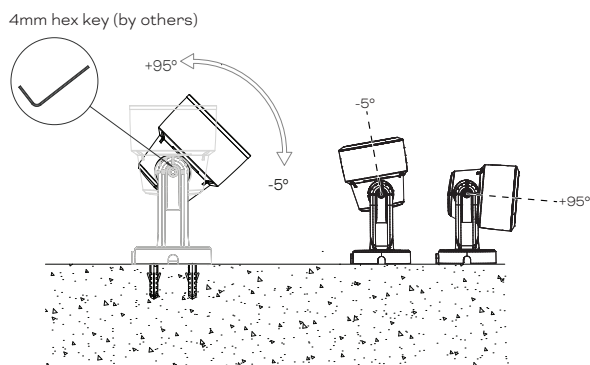

### Tighten the bracket bolts to fix the luminaire to the desired angle

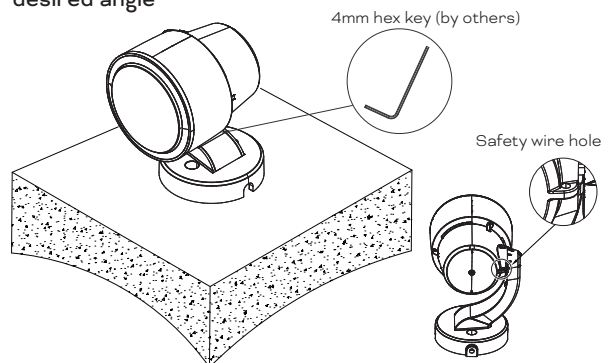

**!** The safety wire must be installed to provide secondary protection to prevent fixtures from falling and injuring people.



## Mounting (Micro)

### Install expansion screws on the fixed surface

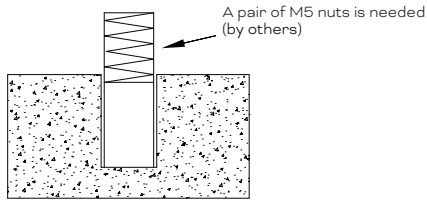

The size of the bracket mounting holes determines the size of the holes to be punched.

### Fix the bracket

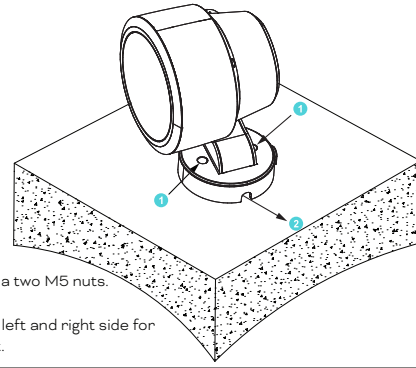

- 1 Fix bracket via two M5 nuts. (by others)
- 2 Holes on the left and right side for cable in / out.

### Adjust desired angles

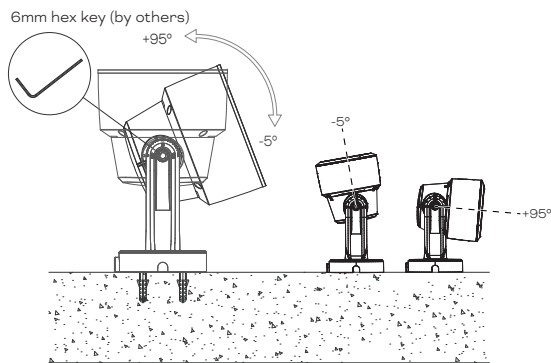

6mm hex key (by others)

### Tighten the bracket bolts to fix the luminaire to the desired angle

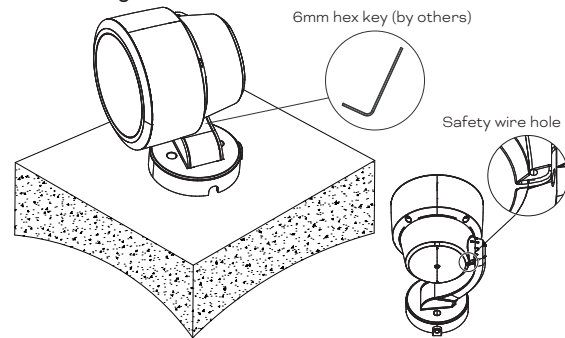

6mm hex key (by others)

Safety wire hole

**!** The safety wire must be installed to provide secondary protection to prevent fixtures from falling and injuring people.

## Mounting (Mini)

### Install expansion screws on the fixed surface

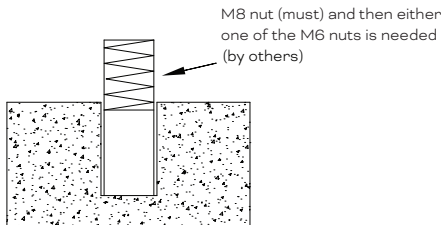

The size of the bracket mounting holes determines the size of the holes to be punched.

### Fix the bracket

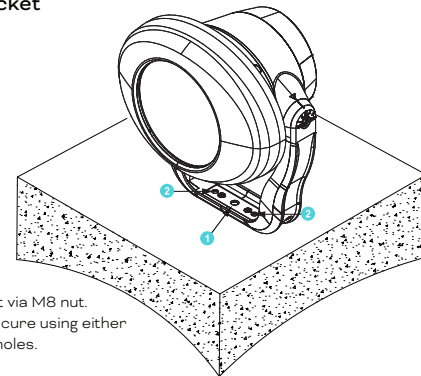

- 1 Fix bracket via M8 nut.
- 2 Further secure using either of the M6 holes. (by others)

### Adjust desired angles

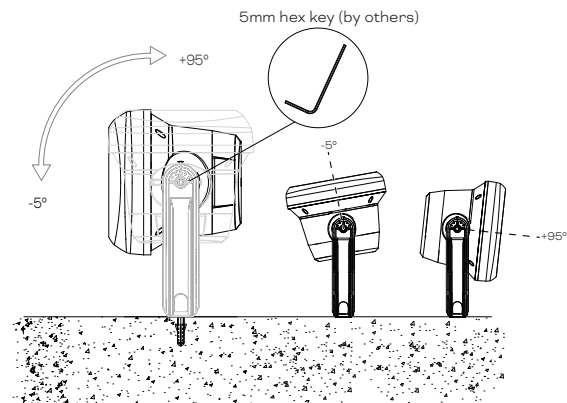

5mm hex key (by others)

### Tighten the bracket bolts to fix the luminaire to the desired angle

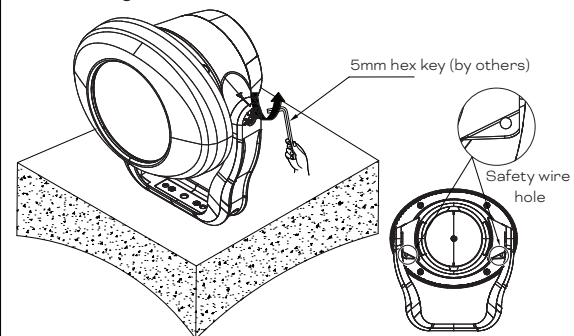

5mm hex key (by others)

Safety wire hole

**!** The safety wire must be installed to provide secondary protection to prevent fixtures from falling and injuring people.



## Mounting (Midi)

### Install expansion screws on the fixed surface

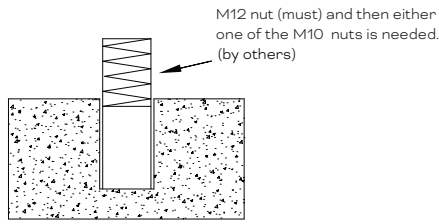

The size of the bracket mounting holes determines the size of the holes to be punched.

### Fix the bracket

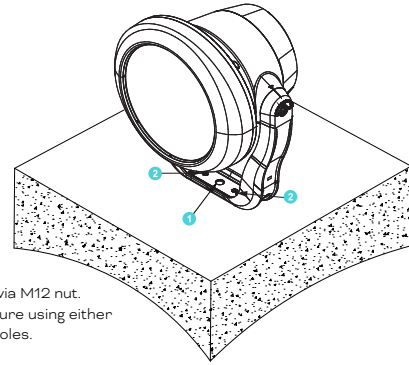

- 1 Fix bracket via M12 nut.
- 2 Further secure using either of the M10 holes. (by others)

### Adjust desired angles

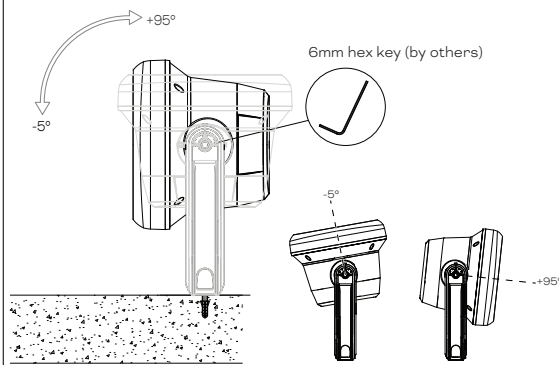

### Tighten the bracket bolts to fix the luminaire to the desired angle

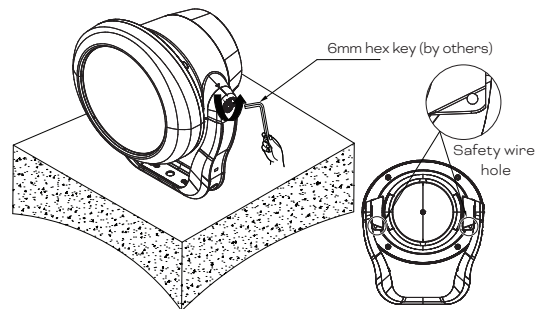

The safety wire must be installed to provide secondary protection to prevent fixtures from falling and injuring people.

## Mounting (Maxi)

### Install expansion screws on the fixed surface

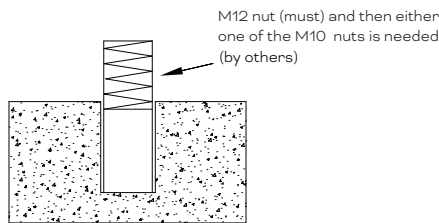

The size of the bracket mounting holes determines the size of the holes to be punched.

### Fix the bracket

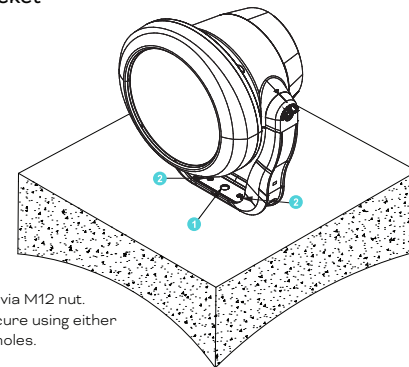

- 1 Fix bracket via M12 nut.
- 2 Further secure using either of the M10 holes. (by others)

### Adjust desired angles

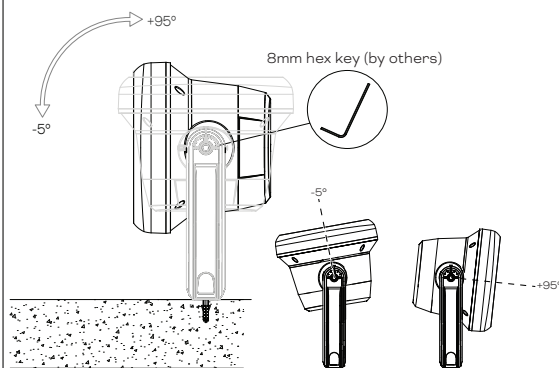

### Tighten the bracket bolts to fix the luminaire to the desired angle

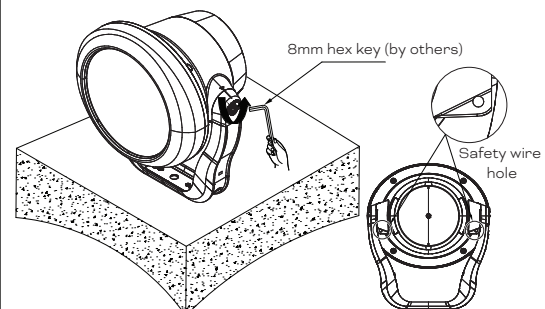

The safety wire must be installed to provide secondary protection to prevent fixtures from falling and injuring people.



<p><b>EN</b></p> <ul style="list-style-type: none"> <li>-CONNECT TO THE POWER SUPPLY IN ACCORDANCE WITH NATIONAL REGULATIONS.</li> <li>-THE EXTERNAL FLEXIBLE CABLE OR CORD OF THIS LUMINAIRE CANNOT BE REPLACED; IF THE CORD IS DAMAGED, THE LUMINAIRE SHALL BE DESTROYED.</li> <li>-THE LIGHT SOURCE OF THIS LUMINAIRE IS NOT REPLACEABLE; WHEN THE LIGHT SOURCE REACHES ITS END OF LIFE THE WHOLE LUMINAIRE SHALL BE REPLACED.</li> <li>-INSTALLATION/MAINTENANCE ONLY BY SKILLED PERSONNEL.</li> <li>-DURING OVERHAUL/MAINTENANCE ONLY USE ORIGINAL PARTS.</li> <li>-IF ANY LUMINAIRE IS SUBSEQUENTLY MODIFIED, THE PERSON RESPONSIBLE FOR THE MODIFICATION SHALL BE CONSIDERED THE MANUFACTURER.</li> <li>-THE MANUFACTURER BEARS NO LIABILITY FOR DAMAGE CAUSED BY INAPPROPRIATE USE OR APPLICATION.</li> </ul>	<p><b>DE</b></p> <ul style="list-style-type: none"> <li>-NETZANSCHLUSS BITTE NACH DEN LÄNDERSPEZIFISCHEN ERRICHTUNGSBESTIMMUNGEN TÄTIGEN</li> <li>-FALLS DAS EXTERNE FLEXIBLE KABEL DIESER LEUCHTE BESCHÄDIGT IST, DARF ES AUSSCHLIESSLICH ERSETZT WERDEN DURCH DEN HERSTELLER ODER EINER ÄHNLICH QUALIFIZIERTEN PERSON, UM GEFÄHRDUNGEN ZU VERMEIDEN.</li> <li>-MONTAGE/WARTUNG NUR DURCH FACHKRÄFTE</li> <li>-BEI INSTANDSETZUNG/INSTANDHALTUNG NUR ORIGINALTEILE VERWENDEN.</li> <li>-WERDEN NACHTRÄGLICH ÄNDERUNGEN AN LEUCHTEN VORGENOMMEN, SO GILT DERJENIGE ALS HERSTELLER, DER DIESE ÄNDERUNG VORNIMMT.</li> <li>-DER HERSTELLER ÜBERNIMMT KEINE HAFTUNG FÜR SCHÄDEN, DIE DURCH UNSACHGEMÄSSEN EINSATZ ENTSTEHEN.</li> </ul>
<p><b>FR</b></p> <ul style="list-style-type: none"> <li>-CONNEXION À L'ALIMENTATION CONFORMÉMENT AUX NORMES EN VIGUEUR.</li> <li>-SI LE CÂBLE EXTÉRIEUR SOUPLE OU LE CORDON DE CE LUMINAIRE EST ENDOMMAGÉ, IL DOIT ÊTRE REMPLACÉ EXCLUSIVEMENT PAR LE FABRICANT, OU TOUTE PERSONNE DE QUALIFICATION ÉQUIVALENTE, CECI AFIN D'ÉVITER TOUT RISQUE.</li> <li>-LES OPERATIONS D'INSTALLATION ET D'ENTRETIEN DOIVENT ÊTRE EFFECTUÉES EXCLUSIVEMENT PAR DES PERSONNES QUALIFIÉES.</li> <li>-DANS LE CAS D'UNE REMISE EN ÉTAT, UTILISER UNIQUEMENT DES COMPOSANTS D'ORIGINE.</li> <li>-TOUTES MODIFICATIONS APPORTÉES AU LUMINAIRE SE FERONT SOUS LA RESPONSABILITÉ EXCLUSIVE DE CELUI QUI LES EFFECTUE.</li> <li>-LE FABRICANT DÉCLINE TOUTE RESPONSABILITÉ RESULTANT D'UN MISE EN ŒUVRE INAPPROPRIÉE DU PRODUIT.</li> </ul>	<p><b>IT</b></p> <ul style="list-style-type: none"> <li>-EFFETTUARE L'ALLACCIAMENTO ALLA RETE SECONDO LE NORME DI INSTALLAZIONE VIGENTI NEL PAESE D'UTILIZZO.</li> <li>-SE IL CAVO FLESSIBILE ESTERNO DI QUESTO APPARECCHIO D'ILLUMINAZIONE È DANNEGGIATO, PER EVITARE PERICOLI ESSO PUÒ ESSERE SOSTITUITO ESCLUSIVAMENTE DAL PRODUTTORE O DA PERSONA DOTATA DI ANALOGA QUALIFICA.</li> <li>-MONTAGGIO/MANUTENZIONE SOLO PER MEZZO DI PERSONALE SPECIALIZZATO.</li> <li>-PER RIPARAZIONE/MANUTENZIONE IMPIEGARE SOLO PARTI ORIGINALI.</li> <li>-IL COSTRUTTORE SI RISERVA IL DIRITTO DI APPORTARE SENZA PREAVVISO MODIFICHE DI PESO, DIMENSIONI E CARATTERISTICHE TECNICHE.</li> <li>-IL COSTRUTTORE NON È RESPONSABILE PER DANNI DERIVANTI DA MODIFICHE REALIZZATE DA TERZI E DA UNA INSTALLAZIONE NON CORRETTA.</li> </ul>
<p><b>ES</b></p> <ul style="list-style-type: none"> <li>-LA CONEXIÓN A RED DEBE DE REALIZARSE SIGUIENDO LAS NORMAS ESPECÍFICAS DE CADA PAÍSES.</li> <li>-EN CASO DE QUE EL CABLE EXTERNO FLEXIBLE DE ESTA LUMINARIA ESTE DAÑADO SÓLO PUEDE REEMPLAZARSE POR EL FABRICANTE O UNA PERSONA SIMILAR CUALIFICADA, PARA EVITAR PELIGROS.</li> <li>-EL MONTAJE Y MANTENIMIENTO LO EFECTUARÁN ÚNICAMENTE LOS TÉCNICOS ESPECIALIZADOS.</li> <li>-PARA REPARACIONES HAN DE EMPLEARSE SOLO PIEZAS ORIGINALES DE RECAMBIO.</li> <li>-RESERVADO EL DERECHO DE MODIFICACION DE DIMENSIONES, PESOS Y CARACTERISTICAS TECNICAS, SIN PREVIO AVISO.</li> <li>-EL FABRICANTE NO ASSUME RESPONSABILIDAD POR MODIFICACIONES REALIZADAS POR TERCEROS, NIP OR INSTALACION INCORRECTA.</li> </ul>	<p><b>PT</b></p> <ul style="list-style-type: none"> <li>-LIGAR À FONTE DE ALIMENTAÇÃO, DE ACORDO COM A REGULAMENTAÇÃO NACIONAL.</li> <li>-CASO O CABO EXTERNO E FLEXÍVEL DA LUMINÁRIA SE DANIFIQUE, DEVE SER SUBSTITUÍDO PELO FABRICANTE OU PESSOA IGUALMENTE QUALIFICADA, PARA EVITAR SITUAÇÕES DE PERIGO.</li> <li>-MONTAGEM/MANUTENÇÃO EFECTUADA UNICAMENTE POR PESSOAL TÉCNICO ESPECIALIZADO.</li> <li>-UTILIZAR SOMENTE PEÇAS ORIGINAIS DO FABRICANTE.</li> <li>-O FABRICANTE NÃO SE RESPONSABILIZA POR DANOS RESULTANTES DA INADEQUADA UTILIZAÇÃO DOS MATERIAIS.</li> </ul>
<p><b>EL</b></p> <ul style="list-style-type: none"> <li>-ΗΣΥΝΔΕΣΗ ΜΕ ΤΗΝ ΠΑΡΟΧΗ ΡΕΥΜΑΤΟΣ ΝΑ ΓΙΝΕΤΑΙ ΣΥΜΦΩΝΑ ΜΕ ΤΙΣ ΕΘΝΙΚΕΣ ΠΡΟΔΙΑΓΡΑΦΕΣ.</li> <li>-ΣΕ ΠΕΡΙΠΤΩΣΗ ΠΟΥ ΤΟ ΕΞΩΤΕΡΙΚΟ ΕΥΚΑΜΠΤΟ ΚΑΛΩΔΙΟ ΑΥΤΟΥ ΤΟΥ ΦΩΤΙΣΤΙΚΟΥ ΕΙΝΑΙ ΚΑΤΕΣΤΡΑΜΜΕΝΟ, ΠΡΕΠΕΙ ΝΑ ΑΝΤΙΚΑΤΑΣΤΑΘΕΙ ΑΠΟΚΛΕΙΣΤΙΚΑ ΚΑΙ ΜΟΝΟ ΑΠΟ ΤΟΝ ΚΑΤΑΣΚΕΥΑΣΤΗ Η ΑΠΟ ΑΛΛΟ ΕΞΟΥΣΙΟΔΟΤΗΜΕΝΟ ΑΤΟΜΟ, ΓΙΑ ΤΗΝ ΑΠΟΦΥΓΗ ΚΙΝΔΥΝΩΝ.</li> <li>-ΤΟΠΟΘΕΤΗΣΗ/ΣΥΝΤΗΡΗΣΗ ΜΟΝΟ ΑΠΟ ΗΛΕΚΤΡΟΛΟΓΟ.</li> <li>-ΚΑΤΑ ΤΗΝ ΕΠΙΣΚΕΥΗ/ΔΙΑΤΗΡΗΣΗ ΧΡΗΣΙΜΟΠΟΙΕΙΤΕ ΓΝΗΣΙΑ ΑΝΤΑΛΛΑΚΤΙΚΑ ΜΟΝΟ.</li> </ul>	<p><b>NL</b></p> <ul style="list-style-type: none"> <li>-AANSLUITEN OP HET LICHTNET, CONFORM DE NATIONALE REGELGEVING.</li> <li>-ALS HET EXTERNE FLEXIBELE SNOER VAN DEZE ARMATUUR BESCHADIGD IS, MAG DIT UITSLUITEND WORDEN VERVANGEN DOOR DE FABRIKANT OF EEN ANDERE GEKWALIFICEERDE PERSOON, OM RISICO'S TE VOORKOMEN.</li> <li>-MONTAGE/SERVICE ALLEEN DOOR VAKKUNDIG PERSONEEL.</li> <li>-BIJ INBEDRIJFSTELLEN/ONDERHOUD ALLEEN ORIGINELE ONDERDELEN GEBRUIKEN.</li> </ul>
<p><b>SV</b></p> <ul style="list-style-type: none"> <li>-NÄTANSLUTNING SKALL SKE ENLIGT NATIONELLA BESTÄMMELSER.</li> <li>-ÄR DEN EXTERNA FLEXIBLA SLADDEN PÅ LAMPAN SKADAD, FÅR ENDAST TILLVERKAREN ELLER EN ANNAN PERSON MED LIKANDE KVALIFIKATIONER BYTA UT DENNA, FÖR ATT UNDVIKA FAROR.</li> <li>-MONTERING AKÖTSEL ENDAAT AV FACKFOLK.</li> <li>-ANVÄND BARA ORIGINALDELAR VID I GANGSÄTTNING/UNDERHÅLL.</li> </ul>	<p><b>NO</b></p> <ul style="list-style-type: none"> <li>-KOBLE TIL STRØMFORSYNINGEN I HENHOLD TIL NASJONALE BESTEMMELSER.</li> <li>-HVIS DEN EKSTERNE OG FLEKSIBLE KABELN TIL DENNE LAMPEN ER SKADET, SÅ MÅ DEN KUN SKIFTES UT AV PRODUSENTEN ELLER EN LIKEVERDIG KVALIFISERT PERSON, FOR AT SKADER UNNGÅS.</li> <li>-MONTERES KUN AV FAGPERONELL.</li> <li>-VED FEILRETNING : BRUK KUN ORGINALDELER.</li> </ul>
<p><b>CZ</b></p> <ul style="list-style-type: none"> <li>-PŘIPOJENÍ K SÍŤOVÉMU NAPĚTÍ DLE PLATNÝCH NÁRODNÍCH NOREM.</li> <li>-POKUD JE EXTERNÍ PRUŽNÝ KABEL TOHOTO SVĚTIDLA POŠKODENÝ, SMÍ JEHO VÝMĚNU PROVĚST POUZE VÝROBCE NEBO PODOBNĚ KVALIFIKOVANÁ OSOBA, ABY NEDOŠLO K ŽÁDNÉMU OHROŽENÍ.</li> <li>-MONTÁŽ A ÚDRŽBA MŮŽE BÝT PROVÁDĚNA VÝHRADNĚ ODBORNOU OSOBOU.</li> <li>-PŘI ÚDRŽBĚ NEBO OPRAVĚ MUSÍ BÝT POUŽITÝ JEN ORIGINALNÍ NÁHRADNÍ DÍLY.</li> </ul>	<p><b>RU</b></p> <ul style="list-style-type: none"> <li>-ВЫПОЛНИТЬ ПОДКЛЮЧЕНИЕ К СЕТИ В СООТВЕТСТВИИ С ПРИНЯТЫМИ В ДАННОЙ СТРАНЕ ПРАВИЛАМИ МОНТАЖА.</li> <li>-В СЛУЧАЕ ПОВРЕЖДЕНИЯ ВНЕШНЕГО ГИБКОГО КАБЕЛЯ ЭТОГО СВЕТИЛЬНИКА, ЧТОБЫ ИСКЛЮЧИТЬ РИСК, ОН ДОЛЖЕН БЫТЬ ЗАМЕНЕН ТОЛЬКО ИЗГОТОВИТЕЛЕМ ИЛИ ЛИЦОМ, ИМЕЮЩИМ ТАКУЮ ЖЕ КВАЛИФИКАЦИЮ.</li> <li>-ПРИ РЕМОНТЕ ПРИМЕНЯТЬ ТОЛЬКО ТЕЖЕ САМЫЕ ЧАСТИ.</li> <li>-МОНТАЖ/ОБСЛУЖИВАНИЕ ТОЛЬКО СПЕЦИАЛИСТАМИ.</li> </ul>
<p><b>HU</b></p> <ul style="list-style-type: none"> <li>-CSATLAKOZTASSA A TÁPEGYSÉGBE A HELYI ELŐÍRÁSOKNAK MEGFELELŐEN.</li> <li>-HA EZEN LÁMPÁK HAJLÍTHATÓ/RUGALMAS KÁBELEI MEGSÉRÜLNÉK, AKKOR AZOK KIZÁRÓLAG CSAK A GYÁRTÓ VAGY HASONLÓAN KVALIFIKÁLT SZEMÉLY ÁLTAL CSERÉLHETŐK KI, HOGY ELKERÜLJÜK A BALESETEKET.</li> <li>-A SZERELÉST/KARBANTARTÁST CSAK SZAKSZEMÉLYZET VÉGEZHETI.</li> <li>-ÜZEMBEHELYEZÉSNEK/KARBANTARTÁSNAK CSAK EREDETI ALKATRÉSZEK HASZNÁLHATÓK.</li> </ul>	<p><b>PL</b></p> <ul style="list-style-type: none"> <li>-ZASILANIE NALEŻY POŁĄCZYĆ ZGODNIE Z WYMAGANIAMI ODPOWIEDNICH NORM.</li> <li>-W PRZYPADKU USZKODZENIA PRZEWODU ZASILAJĄCEGO NALEŻY GO WYMIENIĆ NA NOWY. WYMIANA PRZEWODU MOŻE BYĆ WYKONANA JEDYNI PRZEZ WYKWALIFIKOWANEGO ELEKTRYKA.</li> <li>-MONTAŻ/KONSERWACJA TYLKO PRZEZ FACHOWY PERSONAL.</li> <li>-DLA NAPRAWY/BIEŻĄCEJ EKSPLOATACJI STOSOWAĆ TYLKO ORYGINALNE CZĘŚCI ZAMIANE.</li> </ul>
<p><b>SK</b></p> <ul style="list-style-type: none"> <li>-ZAPOJTE DO EL. PRÍVODU PODĽA PREDPÍSANÝCH NORIEM.</li> <li>-AK JE EXTERNÝ PRUŽNÝ KÁBEL TOHTO SVETIDLA POŠKODENÝ, SMIE BYŤ NAHRADENÝ VÝLUČNE VÝROBCOM ALEBO PODOBNĚ KVALIFIKOVANOU OSOBOU, ABY SA ZABRÁNILO OHROZENIU.</li> <li>-MONTAŽO/VZDRŽEVANJE LAHKO IZVRŠI LE USTREZNO USPOSOBLJENA OSEBA.</li> <li>-PRI POPRAVILU/VZDRŽEVALNIH DELIH SE LAHKO UPORABLJAJO SAMO ORIGINALNI DELI.</li> <li>-V KOLIKOR SE NA SVETILKAH NAKNADNO IZVEDEJO SPREMEMBE, SE ZA PROIZVAJALCA SVETILKE SMATRA TISTI, KI JE IZVEDEL SPREMEMBO.</li> <li>-PROIZVAJALEC NE JAMČI ZA ŠKODO, KI BI NASTALA ZARADI NEPRAVILNE UPORABE.</li> </ul>	<p><b>TR</b></p> <ul style="list-style-type: none"> <li>-ŞEBEKE BAĞLANTISINI LÜTFEN ÜLKEYE ÖZGÜ KURULUM KURALLARI ÇERÇEVESİNDE YAPINIZ.</li> <li>-AVIZENİN [LUMINAIRE] HARICI ESNEK KABLOSUNUN HASAR GÖRMESİ DURUMUNDA, TEHLİKELERDEN KAÇINMAK ÜZERE BU SADECE ÜRETİCİ TARAFINDAN VEYA BENZERİ VASIFLI KIŞİLER TARAFINDAN DEĞİŞTİRİLEBİLİR.</li> <li>-MONTAJ VE BAKIM SADECE YETKİLİ PERSONEL TARAFINDAN YAPILMALIDIR.</li> <li>-BAKIMDA SADECE ORJINAL PARÇALAR KULLANIMALIDIR.</li> </ul>
<p><b>HR</b></p> <ul style="list-style-type: none"> <li>-MOLIMO IZVRŠITE MREŽNI PRIKLJUČAK PREMA SPECIFIČNIM NACIONALNIM ODREDBAMA O NJEGOVOM IZVRŠENJU.</li> <li>-UKOLIKO JE EKSTERNI, FLEKSIBILNI KABEL TE SVJETILJKE OŠTEČEN, ZAMJENA ISTOG JE DOZVOLJENA ISKLJUČIVO PROIZVOĐAČU ILI SLIČNOJ KVALIFICIRANOJ OSOBI, KAKO BI SE IZBEGLJE OPASNOSTI.</li> <li>-MONTAŽU/ODRŽAVANJE MORA VRŠITI ODGOVARJUĆE OSPOSOBLJENA OSOBA.</li> <li>-PRI POPRAVKU/ODRŽAVANJU KORISTITI SAMO ORIGINALNE DIJELOVE.</li> <li>-UKOLIKO SE NA SVJETILJKAMA NAKNADNO VRŠE PROMJENE, ZA PROIZVOĐAČA SVJETILJKE SE SMATRA TAJ KOJI JE PROMJENE IZVRŠIO.</li> <li>-PROIZVOĐAČ NE GARANTUJE ZA ŠTETU KOJA BI MOGLA NASTATI USLED NEPRAVILNE UPOTREBE.</li> </ul>	<p><b>SR</b></p> <ul style="list-style-type: none"> <li>-MOLIMO DA MREŽNI PRIKLJUČAK PROVEDETE PREMA SPECIFIČNIM NACIONALNIM ODREDBAMA O NJEGOVOM PROVEDENJU.</li> <li>-AKO JE EKSTERNI FLEKSIBILNI KABAL OVE SVETILJKE OŠTEČEN, NJEGA SME DA ZAMENI ISKLJUČIVO PROIZVOĐAČ ILI NEKO SLIČNO KVALIFIKOVANO LICE, DA BI SE IZBEGLA UGROŽAVANJA.</li> <li>-MONTAŽU/ODRŽA VANJE MOŽE DA OBAVI SAMO STRUČNO OSPOSOBLJENA OSOBA.</li> <li>-PRI POPRAVLJANJU/ODRŽAVANJU UPOTREBLJAVATI SAMO ORIGINALNE DELOVE.</li> <li>-UKOLIKO SE NA SVETILJKAMA NAKNADNO URADE IZMENE, ZA PROIZVAĐAČA SVETILJKE ĆE SE SMATRATI ONAJ KO IZMENE IZVRŠI.</li> <li>-PROIZVAĐAČ NE GARANTUJE ZA ŠTETU KOJA BI MOGLA NASTATI USLED NEPRAVILNE UPOTREBE.</li> </ul>



TRAXON

TRAXON | ecue